

(12) Indian Patent Application

(21) Application Number: 202041014152

(22) Filing Date: 31/03/2020 (43) Publication Date: 08/10/2021

(71) Applicant(s): L&T TECHNOLOGY SERVICES LTD

(72) Inventor(s): Hariharan, Murugesan
Sundara, Vadivel M

(51) International Classifications: F03D 1/06 A61B 17/56 B29C 70/44 H04S 1/00 F01D 5/28

(54) Title: EXPLOIDABLE WIND TURBINE ROTOR BLADE TIP DESIGN USING SHAPE MEMORY ALLOY

(57) Abstract: A blade (100) of a wind turbine and a method of installing the blade (100) on the wind turbine is disclosed. The blade (100) may include at least one non-reconfigurable portion (102) and at least one reconfigurable portion (104) attached to the at least one non-reconfigurable portion (102). The at least one non-reconfigurable portion (102) may have a fixed shape. The at least one reconfigurable portion (104) may be reconfigurable between a first predetermined shape and a second predetermined shape, in response to application of a stimuli. In the second predetermined shape of the at least one reconfigurable portion (104), the at least one reconfigurable portion (104) and the at least one non-reconfigurable portion (102) may cooperate to form the full-length of the blade (100) of the wind turbine.

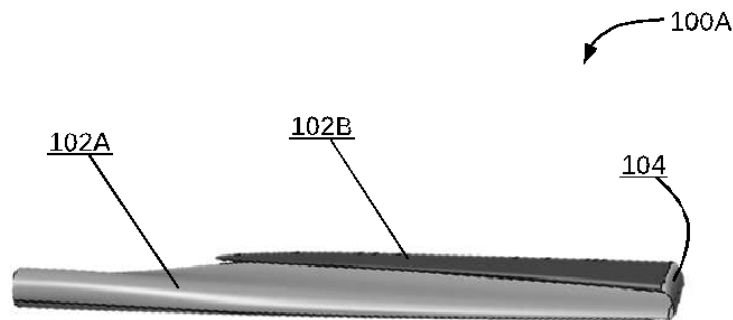

FIG . 1A

FORM 2

THE PATENTS ACT 1970

(39 OF 1970)

&

The Patent Rules, (2003)

Complete Specification

(See Section 10 and Rule 13)

1. TITLE OF THE INVENTION

Exploidable Wind Turbine Rotor Blade Tip Design Using Shape Memory Alloy

2. APPLICANT(S)

(a) NAME : **L&T TECHNOLOGY SERVICES LIMITED**

(b) NATIONALITY : **INDIAN**

(c) ADDRESS : DLF IT SEZ Park, 2nd Floor – Block 3

1/124, Mount Poonamallee Road

Ramapuram, Chennai – 600 089,

INDIA

3. PREAMBLE TO THE DESCRIPTION

COMPLETE

The following specification particularly describes the invention and the manner in which it is performed.

DESCRIPTION

TECHNICAL FIELD

[001] This disclosure relates generally to blades of a wind turbine, and more particularly to the blades of wind turbines that use a shape memory material.

5

BACKGROUND

[002] In recent times, renewable resources of energy, like, wind energy, play an important role for fulfillment of energy demand. It may be understood that power generated by the wind turbine is directly proportional to a surface area of a rotor blade. Therefore, blade length of the rotor blade may be increased proportionally to increase generation of the power.

10

[003] In certain scenarios, for higher turbine capacity, the blade length of the rotor blade associated with the wind turbine may reach beyond a large size, such as, a size of 100 meters. Typically, a blade length beyond 32 meters may cross an upper limit of consignment carrying capacity of road transportation means, and may demand some special kind of transportation. Such special kind of transportation may prove time-consuming and expensive. Further, it may be challenging to maintain structural strength and safe handling of huge blades during production, transportation, and installation. Moreover, the transportation of the huge blades may consume more time, manpower, and may have higher possibility of damage during the transportation.

15

[004] Accordingly, there is a need for a cost-effective and an efficient blade design that can be handled easily during stages of production, transportation, and installation. Additionally, there is a need that such blade design would not affect performance of the wind turbine.

20

SUMMARY OF THE INVENTION

[005] In accordance with an embodiment, a blade of a wind turbine is disclosed. The blade may include at least one non-reconfigurable portion having a fixed shape, and at least one reconfigurable portion attached to the at least one non-reconfigurable portion. The at least one reconfigurable portion may be reconfigurable between a first predetermined shape and a second predetermined shape, in response to application of a stimuli. In the second predetermined shape of the at least one reconfigurable portion, the at least one reconfigurable portion and the at least

25

30

one non-reconfigurable portion may cooperate to form the full-length of the blade of the wind turbine.

5 [006] In accordance with an embodiment, a method of installing a blade on a wind turbine is disclosed. The method may include receiving the blade on a wind turbine site in a first state of the blade. The blade may include at least one non-reconfigurable portion having a fixed shape. The blade may further include at least one reconfigurable portion attached to the at least one non-reconfigurable portion. The at least one reconfigurable portion may be reconfigurable between a first predetermined shape and a second predetermined shape, in response to application of a stimuli. In the first state of the blade, the at least one reconfigurable portion
10 may be of the first predetermined shape. the method may further include applying the stimuli to the at least one reconfigurable portion to obtain a second state of the blade. In the second state of the blade, the at least one reconfigurable portion may be of the predetermined shape. Further, in the second state of the blade, the at least one reconfigurable portion and the at least one non-reconfigurable portion may cooperate to form the full-length of the blade.

15 [007] It is to be understood that both the foregoing general description and the following detailed description are exemplary and explanatory only and are not restrictive of the invention, as claimed.

BRIEF DESCRIPTION OF THE DRAWINGS

20 [008] The accompanying drawings, which are incorporated in and constitute a part of this disclosure, illustrate exemplary embodiments and, together with the description, serve to explain the disclosed principles.

[009] **FIG. 1A** illustrates a perspective view of a blade of a wind turbine in a folded shape, in accordance with an embodiment of the present disclosure.

25 [010] **FIG. 1B** illustrates a side view of a blade of a wind turbine in a folded shape, in accordance with an embodiment of the present disclosure.

[011] **FIG. 1C** illustrates a perspective view of the blade of the wind turbine in an expanded state, in accordance with an embodiment of the present disclosure.

[012] **FIG. 1D** illustrates another perspective view of a blade of a wind turbine in a folded shape, in accordance with another embodiment of the present disclosure.

[013] FIG. 1E illustrates a zoomed-in view of a blade of a wind turbine, in accordance with an embodiment of the present disclosure.

[014] FIG. 1F illustrates a rotor of a wind turbine having three blades in a folded shape, in accordance with an embodiment of the present disclosure.

5 [015] FIG. 1G illustrates a rotor of a wind turbine having three blades in an expanded (original) state, in accordance with an embodiment of the present disclosure.

[016] FIG. 2A illustrates a perspective view of a blade of a wind turbine in a rolled shape, in accordance with another embodiment of the present disclosure.

10 [017] FIG. 2B illustrates a perspective view of the blade of the wind turbine in an expanded state, in accordance with another embodiment of the present disclosure.

[018] FIGS. 3A-3G illustrate line diagrams of a blade of a wind turbine in a folded state and an expanded state, in accordance with another embodiment of the present disclosure.

[019] FIGS. 4A-4B illustrate line diagrams of the blade of a wind turbine in a rolled state and an expanded state respectively, in accordance with another embodiment of the present disclosure.

15 [020] FIG. 5 is a flowchart that illustrates an exemplary method for installing a blade on a wind turbine, in accordance with an embodiment of the present disclosure.

DETAILED DESCRIPTION OF THE DRAWINGS

[021] Exemplary embodiments are described with reference to the accompanying drawings. Wherever convenient, the same reference numbers are used throughout the drawings to refer to the same or like parts. While examples and features of disclosed principles are described herein, modifications, adaptations, and other implementations are possible without departing from the spirit and scope of the disclosed embodiments. It is intended that the following detailed description be considered as exemplary only, with the true scope and spirit being indicated by the following claims. Additional illustrative embodiments are listed below.

25 [022] The following described implementations may be found in the disclosed blade for a wind turbine and a method for installing a blade on a wind turbine. The disclosed blade used for a wind turbine and the method for installing the blade on the wind turbine may be capable of folding or rolling during handling stage and expanding to original size and shape during
30 functional stage of using the blade for the wind turbine. Consequently, the blade may become compact and may be easily transported.

[023] Referring to FIG. 1A and FIG. 1B, a perspective view 100A and a side view 100B, respectively, of a blade 100 of a wind turbine in a folded shape is illustrated, in accordance with an embodiment of the present disclosure. The blade 100 may include at least one non-reconfigurable portion (also referred as a rigid portion) having a fixed shape. For example, as shown in FIG. 1, the blade 100 may include a first non-reconfigurable portion 102A and a second non-reconfigurable portion 102B. In some embodiments, the first non-reconfigurable portion 102A and the second non-reconfigurable portion 102B may be made up of a composite material. It may be noted that the construction of the first non-reconfigurable portion 102A and the second non-reconfigurable portion 102B may be similar to that of a conventionally known blade. Further, the composite material may be a conventionally known material suitable for making blades of wind turbines. Further, the first non-reconfigurable portion 102A and the second non-reconfigurable portion 102B may have a non-reconfigurable shape.

[024] In some embodiments, the blade 100 may further include a reconfigurable portion attached to the at least one non-reconfigurable portion (such as, the first non-reconfigurable portion 102A or the second non-reconfigurable portion 102B). For example, as shown in FIG. 1, the blade 100 includes a reconfigurable portion 104 attached to the first non-reconfigurable portion 102A through one end and to the second non-reconfigurable portion 102B through the other end of the reconfigurable portion 104.

[025] The reconfigurable portion 104 may be flexible and, therefore, configurable between a first predetermined shape and a second predetermined shape in response to application of a stimuli. It will be apparent to a person skilled in the art that the configurability of the reconfigurable portion 104 is not limited to the first and second predetermined shape. In accordance with an embodiment, the stimuli may include subjecting the reconfigurable portion 104 to at least one of a temperature, a pressure, an electric field, or a magnetic field. It will be apparent to a person skilled in the art that a predefined value associated with the temperature, the pressure, the electric field, or the magnetic field may be applied.

[026] In some embodiments, the reconfigurable portion 104 of the blade 100 may be made up of a shape memory material. The shape memory material may correspond to, without limitation, a Shape Memory Alloy (SMA) and a Shape Memory Polymer. As it will be understood by those skilled in the art, the SMA corresponds to an alloy that may be in a deformed shape when not charged, but may return to a pre-deformed shape when a stimulus of heat is applied. For example,

the SMA is deformed when in a cold state and returns to the pre-deformed shape when gets heated. On heating, transformation of the blade starts is completed at a certain temperature, depending on the SMA composition or loading conditions.

5 [027] As illustrated in FIGS. 1A-1B, the SMA of the reconfigurable portion 104 is in a deformed shape (also referred as the first predetermined shape), and as such, the reconfigurable portion 104 may be in a bent shape or folded state. Such bent shape of the reconfigurable portion 104 may allow the blade 100 to be folded, with the second non-reconfigurable portion 102B of the blade bent over the first non-reconfigurable portion 102A. Therefore, the blade 100 may become compact and may be easily transported.

10 [028] In accordance with an embodiment, the SMA may be selected from at least one of, without limitation, a copper-base alloy, a silver-cadmium alloy, a gold-cadmium alloy, a copper-aluminum-nickel alloy, or a copper-zinc alloy. As a result, the blade 100 may be corrosion resistant. The SMA may typically be made by casting, using vacuum arc melting or induction melting. The way in which the SMA may be trained depends on properties wanted, such as blades
15 suitable for energy harvesting applications using wind turbines. The training may dictate the shape that the SMA remembers when heated. This occurs by heating the SMA so that the dislocations re-order into stable positions, but not so hot that the material recrystallizes.

[029] In accordance with an embodiment, the reconfigurable portion 104 of the blade 100 may further include one or more reinforcement members to strengthen the reconfigurable portion
20 104 that is made up of the shape memory material (such as, the SMA).

[030] Referring now to FIG. 1C, a perspective view 100C of the blade 100 of a wind turbine in the second predetermined shape (expanded state) is illustrated, in accordance with an embodiment of the present disclosure.

[031] In accordance with an embodiment, the reconfigurable portion 104 may be
25 reconfigurable between the first predetermined shape and the second predetermined shape, in response to application of a stimuli. In accordance with an embodiment, in the second predetermined shape of the reconfigurable portion 104, the reconfigurable portion 104, the first non-reconfigurable portion 102A, and the second non-reconfigurable portion 102A together form the blade 100 of full length for the wind turbine.

30 [032] In the expanded state as illustrated in FIG. 1C, the reconfigurable portion 104 of the blade 100 may be configured to be in the second predetermined shape, based on the application

of the stimuli (such as, heat). In accordance with an embodiment, the SMA of the reconfigurable portion 104 is in a pre-deformed shape. In accordance with an embodiment, the pre-deformed shape may be accomplished by charging the SMA, for example, by heating the SMA. As such, the reconfigurable portion 104 may take a straightened shape. Such straightened shape of the reconfigurable portion 104 may cause the blade 100 to attain the expanded state, with the second non-reconfigurable portion 102B stretching across the first non-reconfigurable portion 102A. The reconfigurable portion 104 may be indicative of a transition state from a folding state to an expanded state. Therefore, upon bringing the blade 100 into the expanded state, the blade 100 may be installed on the wind turbine, and used for operations of generating power through the wind turbine.

[033] In accordance with an embodiment, a length of the non-reconfigurable portion (such as, the first non-reconfigurable portion 102A) of the blade 100 may be in a range of 60-70 % of full length of the blade and a length of the non-reconfigurable portion (such as, the reconfigurable portion 104) may be in a range of 30-40 % of the full length of the blade. For example, for a 100-meter blade, the non-reconfigurable portion is 70 meters and the reconfigurable portion is 30 meters.

[034] It may be noted that the SMA exhibits unique properties of pseudo-elasticity and shape memory effect. The SMA can be formed into a shape (such as, the second predetermined shape/pre-deformed shape) and then set to that shape by a high heat treatment. When cooled, the SMA may be bent (such as, the first predetermined shape), stretched or deformed (within limits), and then with subsequent moderate heating, (below the heat setting temperature), the SMA can recover some or all of the deformation. Such properties of the SMA may be used to design the flexible blades (such as, the blade 100) for wind turbines. In some embodiments, the SMA may be selected from a combination of at least one, and without limitation, a copper-base alloy, a silver-cadmium alloy, a gold-cadmium alloy, a copper-aluminum-nickel alloy, and a copper-zinc alloy.

[035] In accordance with an embodiment, the reconfigurable portion 104 may include a mixture of the SMA and a composite material. As mentioned earlier, the application of charge on the reconfigurable portion 104 may provide the heat to the SMA. The heated SMA may change the first shape of the reconfigurable portion 104 from its folded shape to the second shape of the reconfigurable portion 104 in the expanded (original) state.

[036] Referring now to FIG. 1D, another perspective view 100D of the blade 100 in a folded shape is illustrated, in accordance with an embodiment of the present disclosure.

[037] FIG. 1E, further shows a zoomed-in view 100E of the blade 100. As illustrated in FIG. 1E, the blade 100 may include the first non-reconfigurable portion 102A, the second non-reconfigurable portion 102B, and the reconfigurable portion 104 with the zoomed-in view. The reconfigurable portion 104 may be positioned between the first non-reconfigurable portion 102A and the second non-reconfigurable portion 102B. In some embodiments, the reconfigurable portion 104 may include a mixture of the SMA and a composite material, for example, multiple layers of the SMA and the composite material placed adjacent to each other. In accordance with an embodiment, the reconfigurable portion 104 may include one or more reinforcement members to strengthen the reconfigurable portion 104 comprising the shape memory alloy.

[038] Referring now to FIG. 1F, a rotor 100F of a wind turbine having three blades in folded shape is illustrated. In accordance with an embodiment, each blade of the three blades correspond to the blade 100.

[039] FIG. 1G illustrates a rotor 100G of a wind turbine having three blades in an expanded (original) state. In accordance with an embodiment, each blade of the three blades correspond to the blade 100. The expanded state may correspond to the second predetermined shape of the each of the three blades 100.

[040] Referring now to FIG. 2A, a perspective view 200A of a blade 200 of a wind turbine in a rolled state is illustrated, in accordance with another embodiment of the present disclosure.

[041] The blade 200 may include a non-reconfigurable portion 202. In some embodiments, the non-reconfigurable portion 202 may be made up of a composite material. It may be noted that the construction of the non-reconfigurable portion 202 may be similar to that of a conventionally known blade. Further, the composite material may be a conventionally known material suitable for making blades of wind turbines. The non-reconfigurable portion 202 may have a non-reconfigurable shape, that is, a fixed shape.

[042] The blade 200 may further include a reconfigurable portion 204 attached to the non-reconfigurable portion 202. For example, as shown in FIG. 2A, the reconfigurable portion 204 may be attached to the non-reconfigurable portion 202 at a distal end of the non-reconfigurable portion 202.

[043] The reconfigurable portion 204 of the blade 200 may be flexible and, therefore, reconfigurable between a first predetermined shape (in a deformed shape) and a second predetermined shape (in a pre-deformed shape) based on an application of a stimuli. As mentioned above, the reconfigurable portion 204 may be made up of a Shape Memory Material (such as, the SMA). In accordance with an embodiment, such Shape Memory Material may be in a deformed shape when not charged and may return to the pre-deformed shape when charged. For example, the SMA may be deformed when cold and may return to pre-deformed shape when heated.

[044] As shown in FIG. 2A, the SMA of the reconfigurable portion 204 may be in a deformed shape. The reconfigurable portion 204 may be rolled over itself towards the non-reconfigurable portion 202. Such shape of the reconfigurable portion 204 may allow the blade 200 to be rolled, with the reconfigurable portion 204 rolled into a compact shape. Therefore, the blade 200 overall becomes compact and can be easily transported.

[045] Referring now to FIG. 2B, a perspective view 200B of the blade 200 of a wind turbine in an expanded state is illustrated, in accordance with an embodiment of the present disclosure. The rolled state is already discussed in FIG. 2A. In expanded state, the reconfigurable portion 204 may be configured to be in a second predetermined shape. As shown in FIG. 2B, the reconfigurable portion 204 may take a straightened shape. In accordance with an embodiment, the straightened shape of the reconfigurable portion 204 may cause the blade 100 to attain the expanded state, with the reconfigurable portion 204 unrolling to straighten out. Upon bringing the blade 200 into the expanded state, the blade 200 may be installed on the wind turbine and used for operations of generating power through the wind turbine. A method of installing a blade on a wind turbine is disclosed in description of FIG. 5.

[046] FIGS. 3A-3G illustrates line diagrams 300A-300G of the blade 100 of a wind turbine corresponding to FIGS. 1A-1G in a folded state and an expanded state, in accordance with an embodiment of the present disclosure. The description for the blade 100 as illustrated in FIGS. 3A-3G is same as described for FIGS. 1A-1G.

[047] FIGS. 4A-4B illustrates line diagrams 400A-400B of the blade 200 of a wind turbine corresponding to FIGS. 2A-2B in a rolled state and an expanded state, in accordance with an embodiment of the present disclosure. The description for the blade 200 as illustrated in FIGS. 4A-4B is same as described for FIGS. 2A-2B.

[048] FIG. 5 is a flowchart 500 that illustrates an exemplary method for installing a blade on a wind turbine, in accordance with an embodiment of the present disclosure. With reference to FIG. 5, there is shown a flowchart 500. The operations of the flowchart 500 may start at step 502 and proceed to 504.

5 [049] At step 502, a blade 100 may be received on a wind turbine site in a first state of the blade 100. In accordance with an embodiment, the blade 100 may include at least one non-reconfigurable portion 102. In accordance with an embodiment, the at least one non-reconfigurable portion 102 has a fixed shape. In accordance with an embodiment, the at least one reconfigurable portion 104 may be attached to the at least one non-reconfigurable portion
10 102. In accordance with an embodiment, the at least one reconfigurable portion 104 may be reconfigurable between a first predetermined shape and a second predetermined shape, based on an application of a stimuli. In accordance with an embodiment, in the first state of the blade, the at least one reconfigurable portion 104 is of the first predetermined shape. In accordance with an embodiment, the reconfigurable portion 104 comprises a shape memory alloy. In accordance
15 with an embodiment, the shape memory alloy may be selected from at least one of, but not limited to, a copper-base alloy, a silver-cadmium alloy, a gold-cadmium alloy, a copper-aluminum-nickel alloy, and a copper-zinc alloy. In accordance with another embodiment, any shape memory material may be used for the reconfigurable portion 104, such as a shape memory polymer.

20 [050] At step 504, the stimuli may be applied to the at least one reconfigurable portion 104 to obtain a second state of the blade. In accordance with an embodiment, in the second state of the blade 100, the at least one reconfigurable portion 104 may be of the predetermined shape. In accordance with an embodiment, in the second state of the blade 100, the at least one reconfigurable portion 104 and the at least one non-reconfigurable portion 102 may together
25 form the full-length blade 100 of the wind turbine. In accordance with an embodiment, the applying of stimuli may include subjecting the reconfigurable portion 104 to at least one of temperature, pressure, an electric field, or a magnetic field.

[051] At step 506, the blade 100 may be mounted in the second state of the blade 100 on the wind turbine. The second state may correspond to an expanded state of the blade.

30 [052] The present disclosure discusses a flexible type rotor blade of wind turbine. The blade may include the SMA which may be integrated with a composite material of rotor blade. The

above-mentioned technique may provide a cost-effective solution for transporting wind turbine blades in its folded or rolled form, such that the blade may be brought into its expanded shape and erected on the wind turbine. The techniques make the transportation of the blades time-efficient. Further, the techniques provide for easy handling of the blades during production,
5 further help to prevent damage to the integrity of the blade during transportation.

[053] It is intended that the disclosure and examples be considered as exemplary only, with a true scope and spirit of disclosed embodiments being indicated by the following claims.

We claim:

1. A blade (100) of a wind turbine, the blade (100) comprising:

at least one non-reconfigurable portion (102) having a fixed shape; and

at least one reconfigurable portion (104) attached to the at least one non-
5 reconfigurable portion (102),

wherein the at least one reconfigurable portion (104) is reconfigurable between a
first predetermined shape and a second predetermined shape, in response to application of a
stimuli, and

wherein in the second predetermined shape of the at least one reconfigurable portion
10 (104), the at least one reconfigurable portion (104) and the at least one non-reconfigurable
portion (102) cooperate to form the full-length of the blade (100) of the wind turbine.

2. The blade (100) as claimed in claim 1, wherein the at least one reconfigurable portion (104)
comprises a shape memory alloy.

3. The blade (100) as claimed in claim 2, wherein the shape memory alloy is selected from at
least one of a copper-base alloy, a silver-cadmium alloy, a gold-cadmium alloy, a copper-
aluminum-nickel alloy, or a copper-zinc alloy.

4. The blade (100) as claimed in claim 2, wherein the at least one reconfigurable portion (104)
further comprises one or more reinforcement members to strengthen the at least one
reconfigurable portion (104).

5. The blade (100) as claimed in claim 1, wherein the stimuli comprises subjecting the at least
25 one reconfigurable portion (104) to at least one of temperature, pressure, an electric field, or
a magnetic field.

6. The blade (100) as claimed in claim 1, wherein the first predetermined shape is one of a folded
shape or a rolled shape.

7. A method of installing a blade (100) on a wind turbine, the method comprising:

receiving the blade (100) on a wind turbine site in a first state of the blade (100), wherein the blade (100) comprises:

at least one non-reconfigurable portion (102) having a fixed shape; and

5 at least one reconfigurable portion (104) attached to the at least one non-reconfigurable portion (102), wherein the at least one reconfigurable portion (104) is reconfigurable between a first predetermined shape and a second predetermined shape, in response to application of a stimuli, and wherein in the first state of the blade, the at least one reconfigurable portion (104) is of the first predetermined shape; and

10 applying the stimuli to the at least one reconfigurable portion (104) to obtain a second state of the blade, wherein in the second state of the blade, the at least one reconfigurable portion (104) is of the predetermined shape, and wherein in the second state of the blade, the at least one reconfigurable portion (104) and the at least one non-reconfigurable portion (102) cooperate to form the full-length of the blade (100).

15 **8.** The method as claimed in claim 7, further comprising:

mounting the blade (100) in the second state of the blade (100) on the wind turbine.

9. The method as claimed in claim 1,

wherein the reconfigurable portion (104) comprises a shape memory alloy, and

20 wherein the shape memory alloy is selected from at least one of a copper-base alloy, a silver-cadmium alloy, a gold-cadmium alloy, a copper-aluminum-nickel alloy, or a copper-zinc alloy.

10. The method as claimed in claim 7, wherein the stimuli comprises subjecting the
25 reconfigurable portion (104) to at least one of temperature, pressure, an electric field, or a magnetic field.

Dated this 31st Day of March 2020

30 Mohammed Faisal (INPA No: 1941)
Head, IPR Dept.
L&T Technology Services Limited
DLF 3rd Block, 2nd Floor,
Manapakkam, Chennai 600089.

EXPLOIDABLE (DEPLOYABLE) WIND TURBINE ROTOR BLADE TIP DESIGN USING SHAPE MEMORY ALLOY

ABSTRACT

5

A blade (100) of a wind turbine and a method of installing the blade (100) on the wind turbine is disclosed. The blade (100) may include at least one non-reconfigurable portion (102) and at least one reconfigurable portion (104) attached to the at least one non-reconfigurable portion (102). The at least one non-reconfigurable portion (102) may have a fixed shape. The at
10 least one reconfigurable portion (104) may be reconfigurable between a first predetermined shape and a second predetermined shape, in response to application of a stimuli. In the second predetermined shape of the at least one reconfigurable portion (104), the at least one reconfigurable portion (104) and the at least one non-reconfigurable portion (102) may cooperate to form the full-length of the blade (100) of the wind turbine.

15

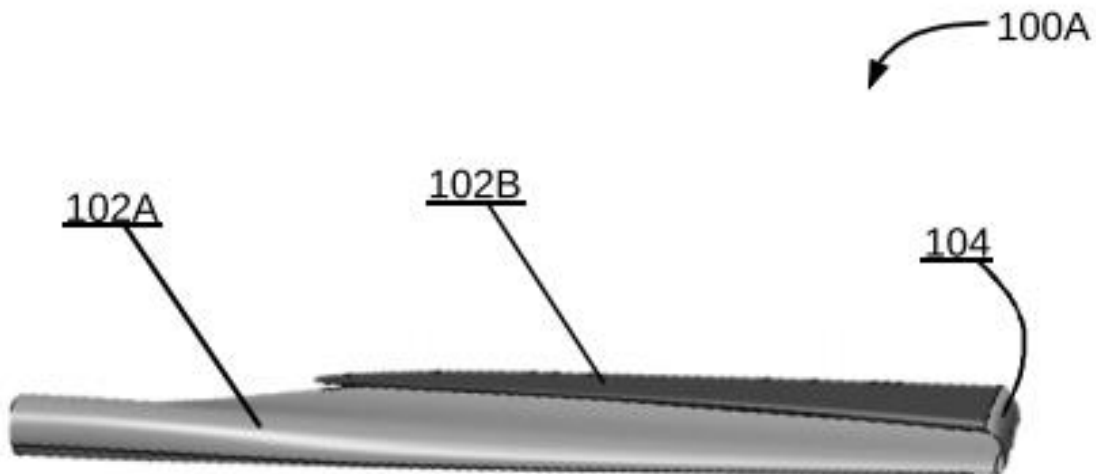

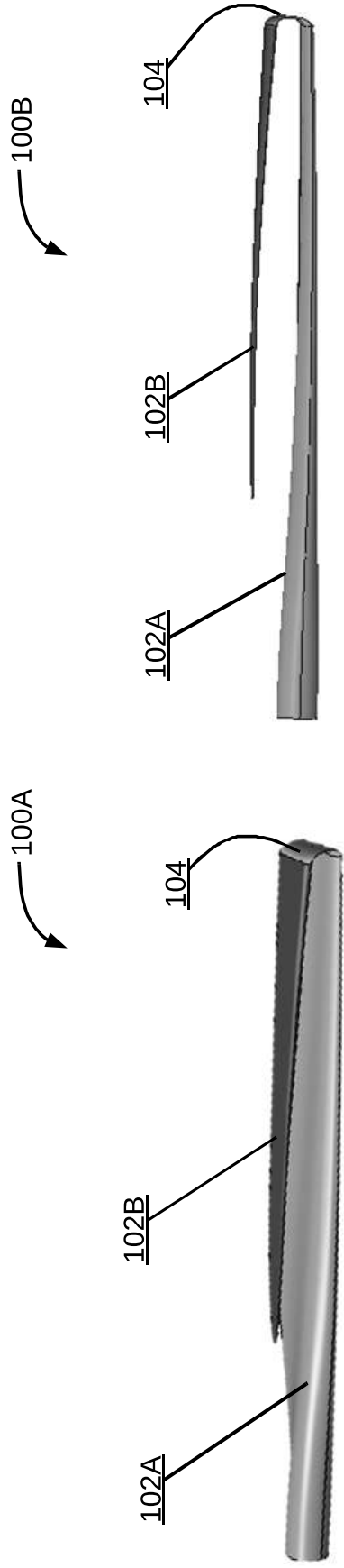

FIG . 1B

FIG . 1A

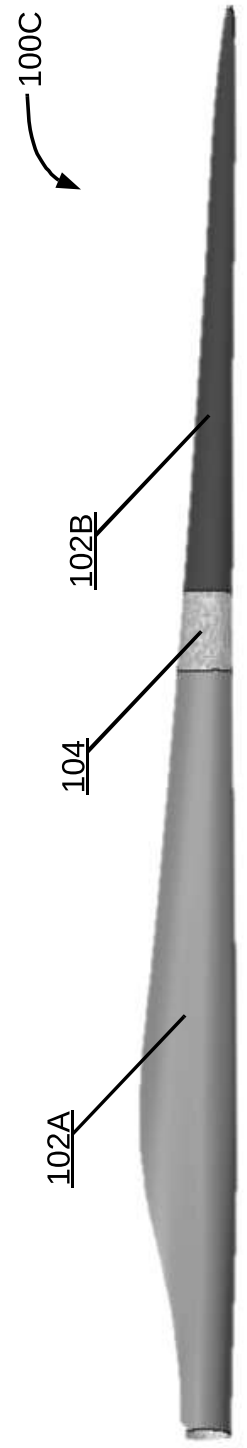

FIG . 1C

Mohammed Faisal (INPA No: 1941)
Head, IPR Dept.,
L&T Technology Services Limited,
DLF 3rd Block, 2nd Floor,
Manapakkam, Chennai - 600089.

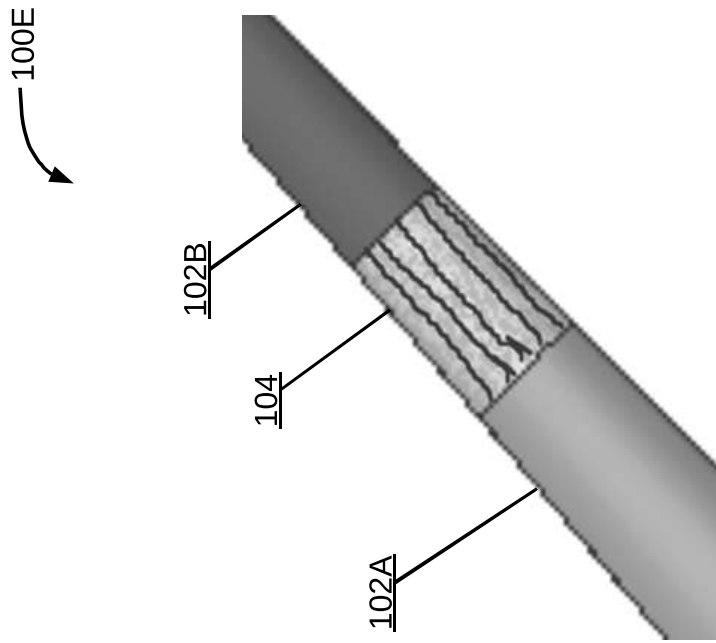

FIG. 1E

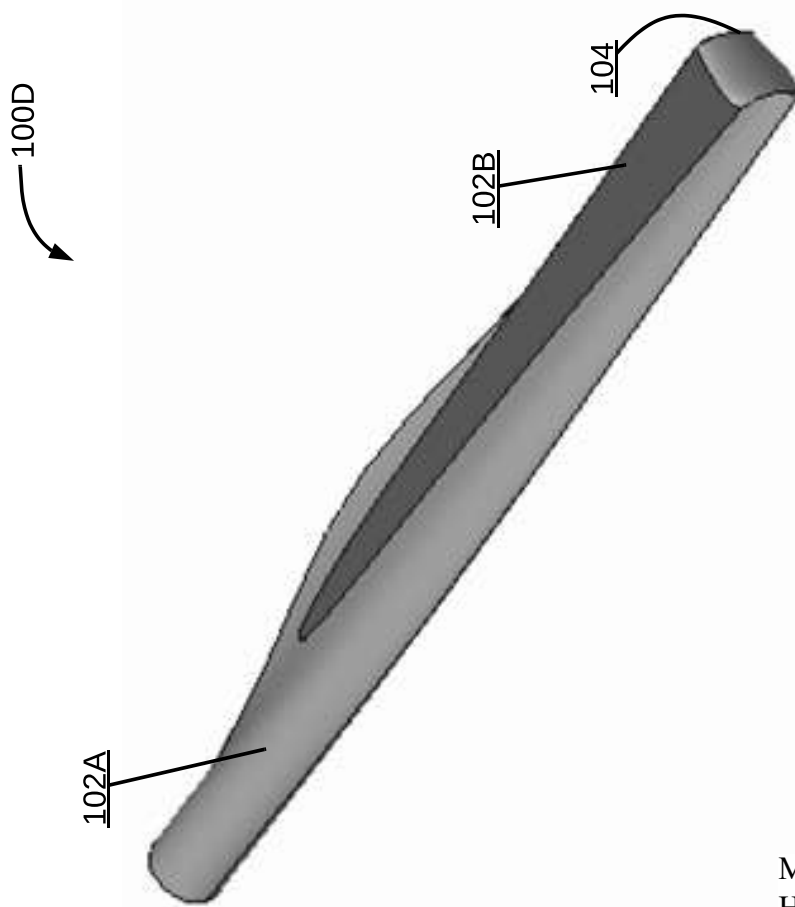

FIG. 1D

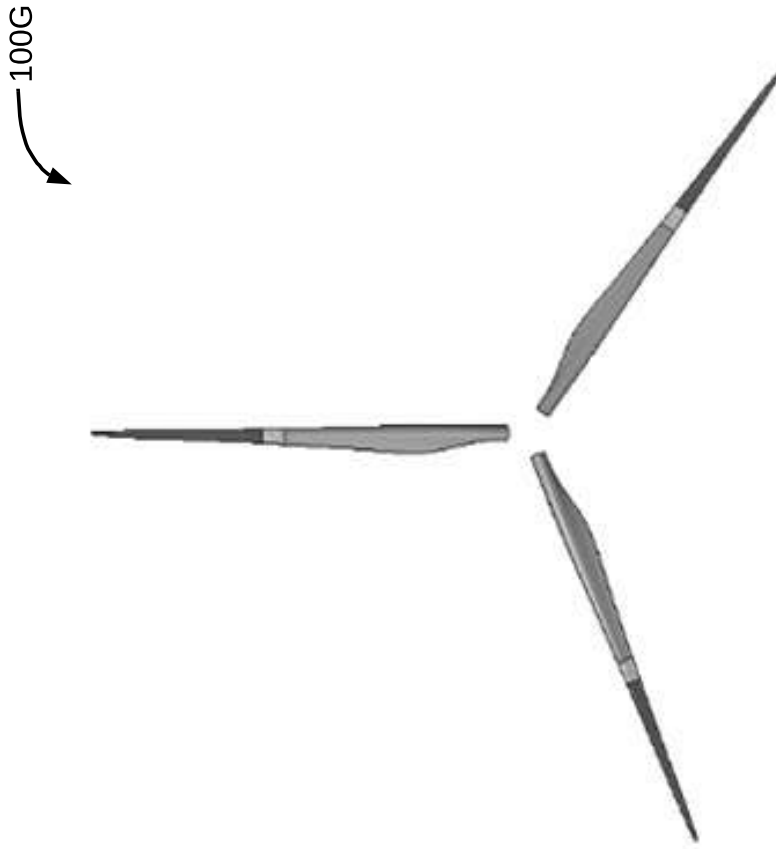

FIG . 1G

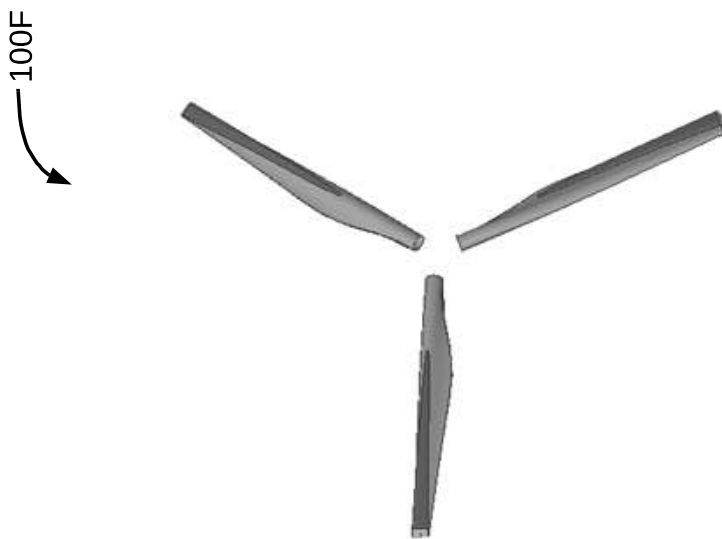

FIG . 1F

Mohammed Faisal (INPA No: 1941)
Head, IPR Dept.,
L&T Technology Services Limited,
DLF 3rd Block, 2nd Floor,
Manapakkam, Chennai - 600089.

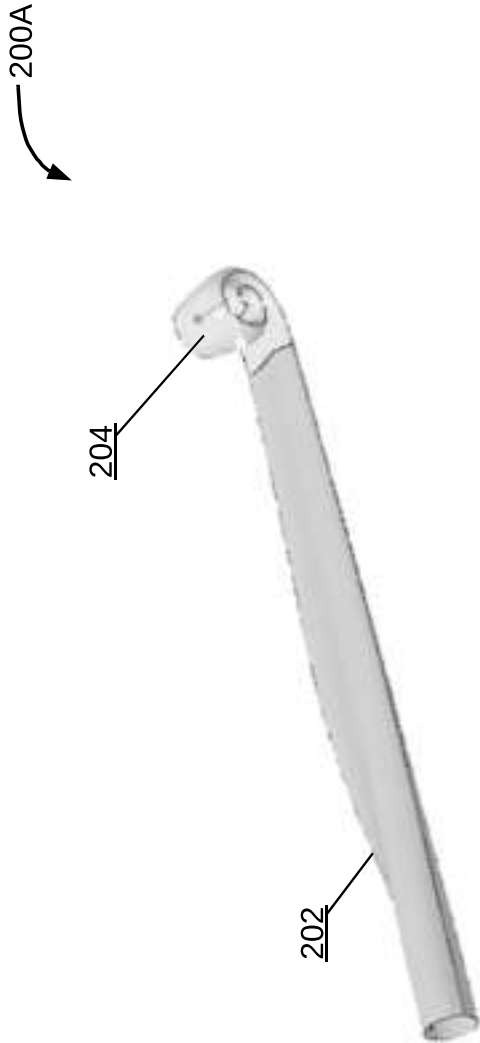

FIG . 2A

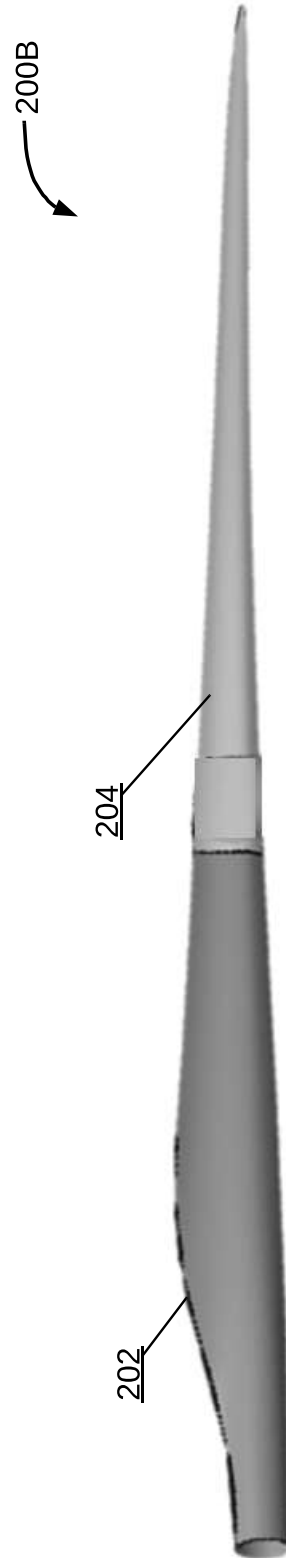

FIG . 2B

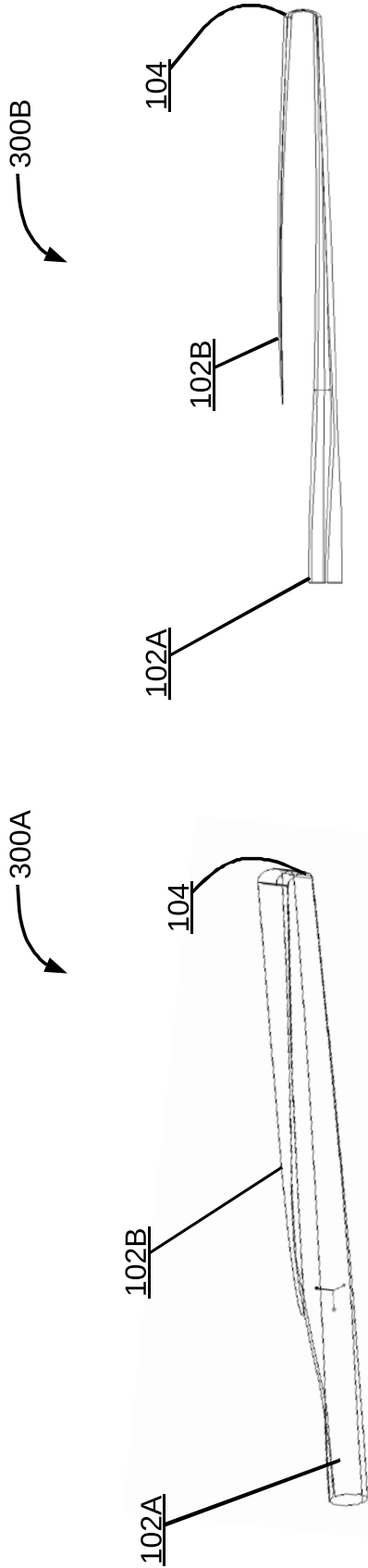

FIG . 3B

FIG . 3A

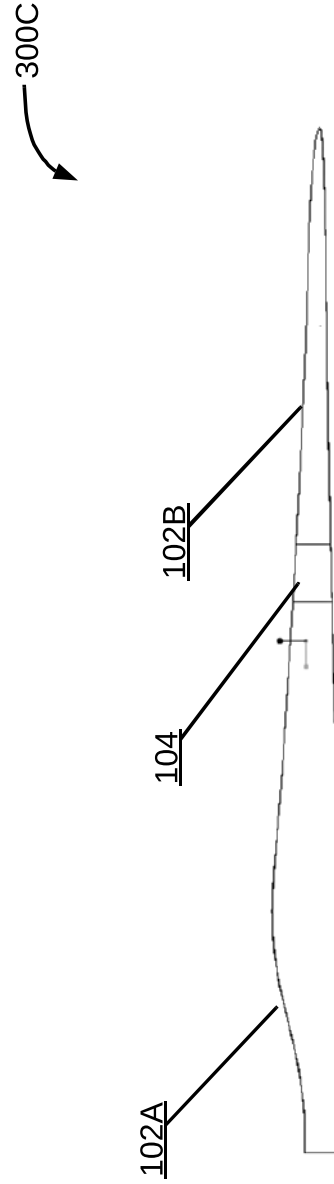

FIG . 3C

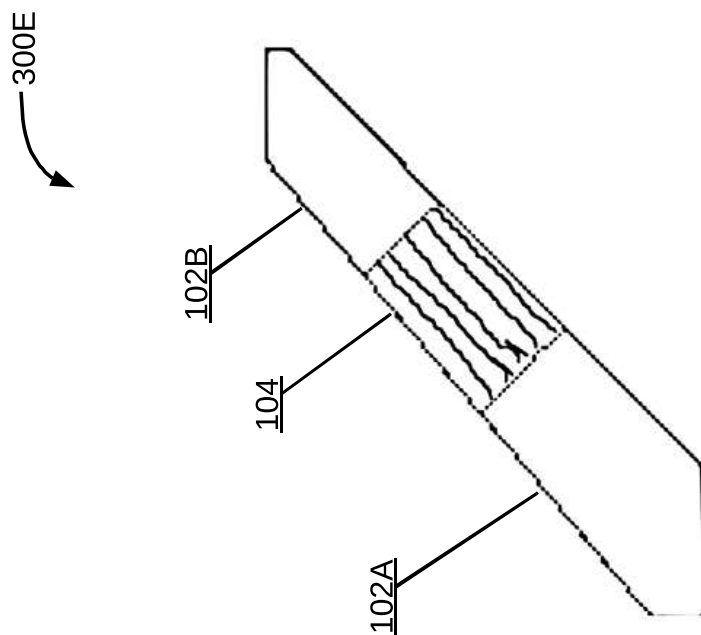

FIG. 3E

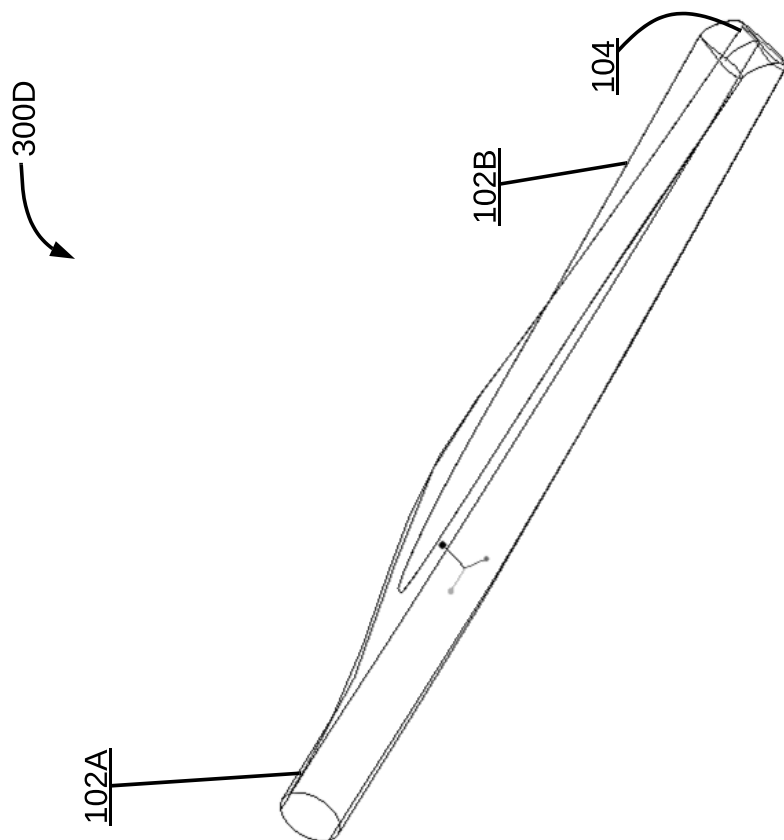

FIG. 3D

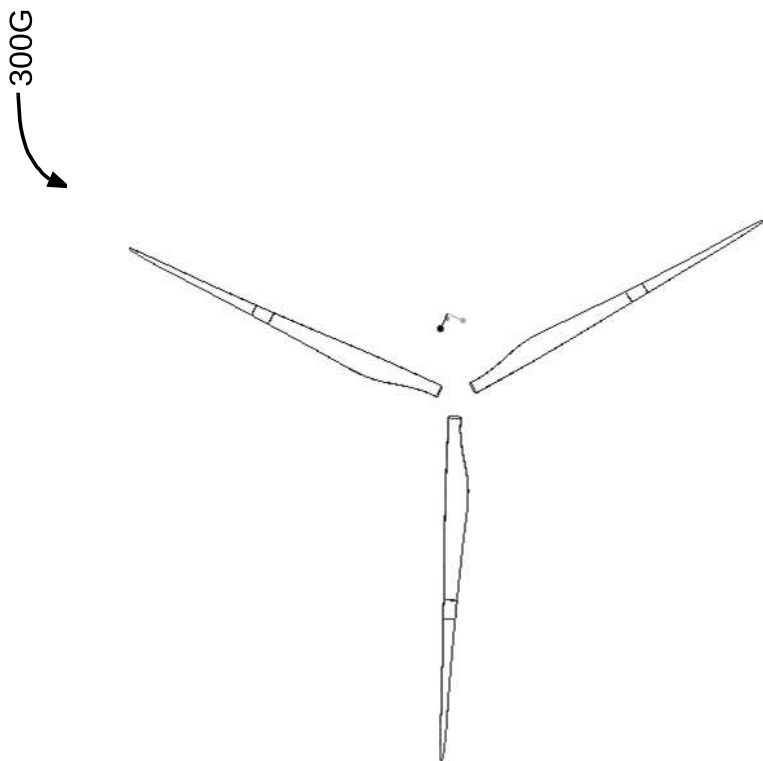

FIG . 3G

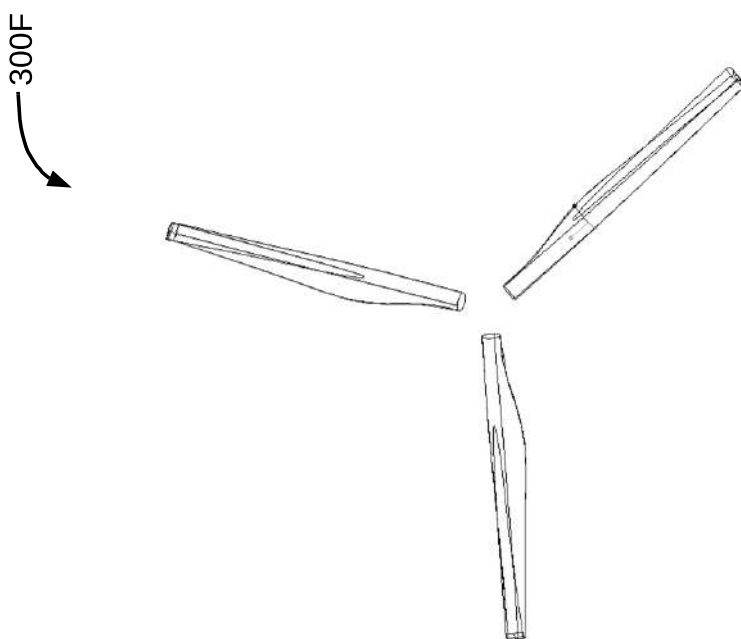

FIG . 3F

Mohammed Faisal (INPA No: 1941)
Head, IPR Dept.,
L&T Technology Services Limited,
DLF 3rd Block, 2nd Floor,
Manapakkam, Chennai - 600089.

400A

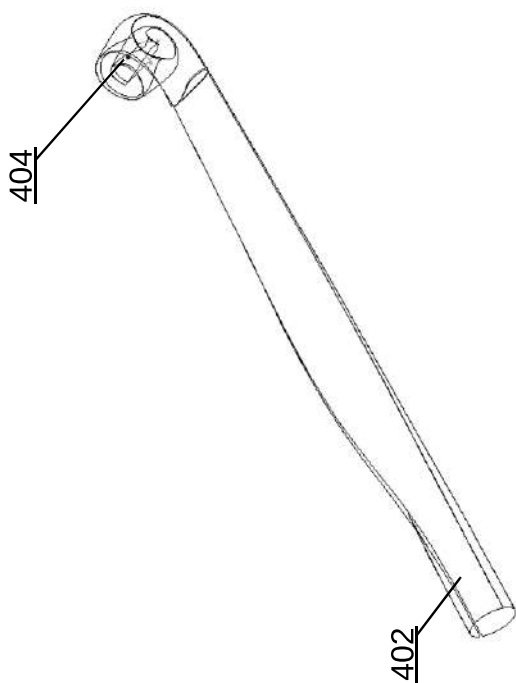

FIG . 4A

400B

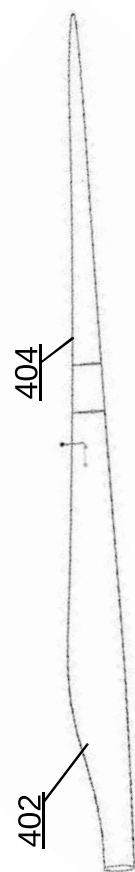

FIG . 4B

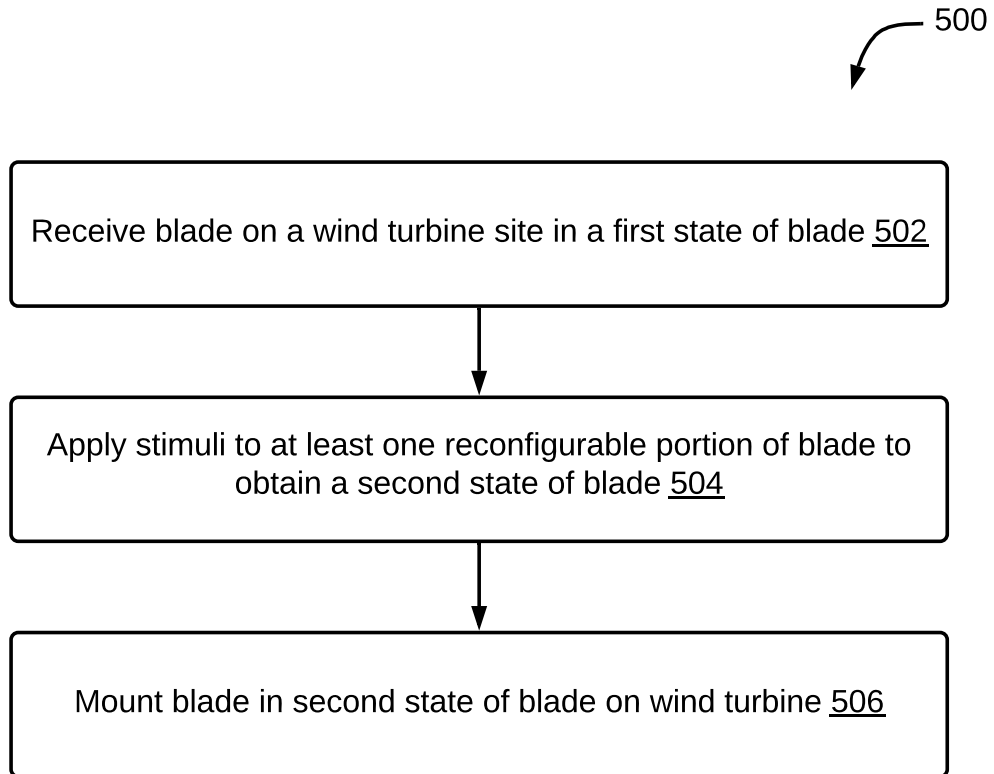

FIG. 5