

## (12) Indian Patent Application

---

(21) Application Number: 202141028451

(22) Filing Date: 24/06/2021 (43) Publication Date: 30/12/2022

(71) Applicant(s): L&T TECHNOLOGY SERVICES LIMITED

(72) Inventor(s): Rao, Balkrishna  
Somasundaram, Krishnakumar  
Ramalingam, Manickam  
Palaniappan, Meyyappan  
Kalyanam, Sendhil Kumar

(51) International Classifications: A61B 17/072 A61B 17/068 A61B 17/00 A61B 17/064 A61B 17/115

(54) Title: A SURGICAL STAPLER

(57) Abstract: A surgical stapler (300) is disclosed. The surgical stapler (300) may include a reload assembly (100) which may further include a cartridge (104A) configured to temporarily hold a plurality of staples within a staple region defined on an inner surface of the cartridge (104A) along the length of the cartridge (104A). The length of the cartridge (104A) extends along a straight line, and the staple region is curve-shaped. The reload assembly (100) may further include an anvil (106A) pivotable relative to the cartridge (104A). The anvil (106A) includes a plurality of cam profiles on an inner surface of the anvil (106A) facing the cartridge (104A). Upon application of a stapling action, one or more cam profiles of the plurality of cam profiles are configured to engage with the plurality of staples held in the cartridge (104A) to secure the plurality of staples on a body part subjected to surgery.

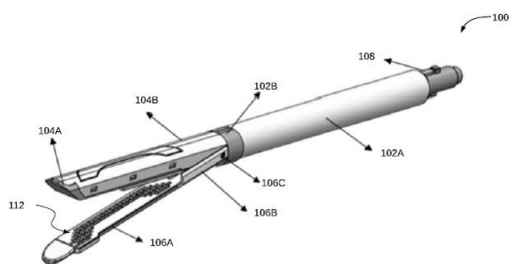

FIG. 1

-- Digitally Signed--

Robin Koshy Varghese  
(INPA No: 3705)  
Head, IPR Dept.,  
L&T Technology Services Limited,  
DLF 3rd Block, 2nd Floor,  
Gurgaon, Haryana, India

# **FORM 2**

THE PATENTS ACT 1970  
(39 OF 1970)  
&  
The Patent Rules, 2003

## **Complete Specification**

(See Section 10 and Rule 13)

### **1. TITLE OF THE INVENTION**

**A SURGICAL STAPLER**

### **2. APPLICANT(S)**

(a) NAME : **L&T TECHNOLOGY SERVICES LIMITED**

(b) NATIONALITY : **INDIAN**

(c) ADDRESS : **DLF IT SEZ Park, 2nd Floor – Block 3**

**1/124, Mount Poonamallee Road,**

**Ramapuram, Chennai – 600 089,**

**INDIA.**

### **3. PREAMBLE TO THE DESCRIPTION**

#### **COMPLETE**

The following specification describes the invention and  
the manner in which it is to be performed

## **DESCRIPTION**

### **Technical Field**

[001] This disclosure relates generally to surgical equipment, and more particularly to a reload assembly of a surgical stapler for sealing of tissues or vessels during surgery.

5

### **BACKGROUND**

[002] Surgical stapler like a laparoscopic stapler is a medical device that has applications in abdominal, gynecologic, pediatric, and thoracic surgery for resection, transection and creation of anastomosis. The laparoscopic stapler may include a handle and a reload assembly. The handle is at surgeon end and allows the surgeon to hold and apply effort to perform the action of stapling. The reload assembly includes surgical staplers which are used to seal the tissues. The reload assembly may be attached to the handle during surgery. Further, a number of reload assemblies may attached to the handle depending on type and area where surgery is performed. The reload assembly may further include a cartridge that usually has six rows of staples with a cutter/knife in the middle. The reload assembly may exist in three variants (based on total staple length): 30mm, 45mm, 60mm and may be inserted laparoscopically through 12mm trocar. Depending on the applications, the reload assemblies may be of two different types that can be attached to the handle i.e., straight profile reload assemblies and curved profile reload assemblies. The straight profile reloads may be used in laparoscopic surgery, that may cut and staple tissue in a straight line. On the other hand, the curved profile reload assemblies may be used in open surgery, and may cut and staple the tissue in a curved manner.

[003] Further, for example, during Nephrectomy procedure, the existing available laparoscopic stapler reload assemblies do not leave enough vein/vessel length after removing kidney from donor site. Due to shortening in length of the vein/vessel, it poses challenges to surgeon during implantation of kidney on recipient body. A renal area is shown in FIG. 13A. Right kidney usually has a shorter renal vein. The surgical straight profile stapler reload assembly which can be inserted laparoscopically is not suitable for cutting and sealing portions of IVC. This is because it provides a straight cut and stapling which in turn cuts more tissue, as shown in FIG. 13B (prior art). Due to the curved overall shape of the curved profile reload assemblies, these are not suitable for laparoscopic procedures. Hence, open surgery needs to be performed while using these curved profile reload assemblies. This leads to longer recovery time and higher risk of infections to the donor.

[004] Therefore, an improved stapler reload with a desirable staple profile to be fit into a trocar of diameter ranges in between 12 millimeter (mm) and 15 mm is desired.

## **SUMMARY OF THE INVENTION**

[005] In an embodiment, a surgical stapler is disclosed. The surgical stapler may include a reload assembly. The reload assembly may further include a cartridge configured to temporarily  
5 hold a plurality of staples within a staple field defined on an inner surface of the cartridge along the length of the cartridge. The length of the cartridge extends along a straight line, and the staple field is curve-shaped. The reload assembly may further include an anvil pivotable relative to the cartridge. The anvil includes a plurality of slots on an inner surface of the anvil facing the cartridge. Upon application of a stapling action, one or more slots of the plurality of slots are configured to  
10 engage with the plurality of staples held in the cartridge to secure the plurality of staples on a body part subjected to surgery. Further, the reload assembly may include a handle for triggering the stapling action through the reload assembly, upon a user intervention.

[006] In another embodiment, a reload assembly for a surgical stapler is disclosed. The reload assembly may include a cartridge configured to temporarily hold a plurality of staples within  
15 a staple field defined on an inner surface of the cartridge along the length of the cartridge. The length of the cartridge extends along a straight line, and wherein the staple field is curve shaped. The reload assembly may further include an anvil pivotable about the cartridge. The anvil may include a plurality of slots on an inner surface of the anvil facing the cartridge, upon application of a stapling action, one or more slots of the plurality of slots are configured to engage with the  
20 plurality of staples held in the cartridge to secure the plurality of staples on a body part subjected to surgery.

## **BRIEF DESCRIPTION OF THE DRAWINGS**

[007] The accompanying drawings, which are incorporated in and constitute a part of  
25 this disclosure, illustrate exemplary embodiments and, together with the description, serve to explain the disclosed principles.

[008] **FIG. 1** illustrates a perspective view of a reload assembly for a surgical stapler, in accordance with an embodiment of the present disclosure.

[009] **FIGS. 2A-2B** illustrate a bottom view of an inner surface of a cartridge of the  
30 reload assembly, in accordance with an embodiment.

[010] **FIG. 3** illustrates a cross-section view of a part of the surgical stapler depicting initialization of stapling action, in accordance with an embodiment.

[011] **FIG. 4** illustrates another cross-section view of a part of the surgical stapler depicting initialization of the stapling action, in accordance with an embodiment.

[012] FIG. 5 illustrates a perspective view of a part of an anvil (showing anvil end), in accordance with an embodiment.

[013] FIG. 6 shows a perspective view of a part of a firing plate (showing plate end), in accordance with an embodiment.

5 [014] FIG. 7 illustrates a cross-section view of a part of the surgical stapler during the stapling action, in accordance with an embodiment.

[015] FIG. 8 illustrates a magnified view of the part of the surgical stapler during the stapling action, in accordance with an embodiment.

10 [016] FIG. 9 illustrates a cross-section view of a part of the surgical stapler depicting completion of the stapling action, in accordance with an embodiment.

[017] FIG. 10 illustrates another cross-section view of a part of the surgical stapler depicting completion of the stapling action, in accordance with an embodiment.

[018] FIG. 11 illustrates a bottom view of the inner surface of a cartridge of a reload assembly, in accordance with another embodiment.

15 [019] FIG. 12 illustrates a flowchart of a process of operating the reload assembly, in accordance with an embodiment.

[020] FIGS. 13A-C illustrate a renal area, the renal with straight line stapling (prior art), and the renal with curved line stapling, respectively.

20 **DETAILED DESCRIPTION OF THE DRAWINGS**

[021] Exemplary embodiments are described with reference to the accompanying drawings. Wherever convenient, the same reference numbers are used throughout the drawings to refer to the same or like parts. While examples and features of disclosed principles are described herein, modifications, adaptations, and other implementations are possible without departing from  
25 the spirit and scope of the disclosed embodiments. It is intended that the following detailed description be considered as exemplary only, with the true scope and spirit being indicated by the following claims. Additional illustrative embodiments are listed below.

[022] Referring to FIG. 1, a perspective view of a reload assembly 100 for a surgical stapler is illustrated, in accordance with an embodiment of the present disclosure. FIG. 2A  
30 illustrates a bottom view of the inner surface of the cartridge 104A of the reload assembly 100, in accordance with an embodiment of the present disclosure. FIG. 2B illustrates a bottom view of the inner surface of the cartridge 104A of the reload assembly 100 depicting dimensions of the various parts of the design, in accordance with an embodiment of the present disclosure. The reload assembly 100 may include an outer tube 102A, an inner tube 102B, a cartridge 104A, a cartridge

cover 104B, an anvil 106A, an anvil cover 106B, a pivot pin 106C, and a lock ring 108 (also known as sleeve lock).

5 [023] In some embodiments, the cartridge 104A may be fixed to the inner tube 102B of the reload assembly 100 via the cartridge cover 104B. In some embodiments, the cartridge 104A may be configured to temporarily hold a plurality of staples within a staple field 110 defined on the inner surface of the cartridge 104A along the length of the cartridge 104A. As it can be seen in FIGS. 1-2, the length of the cartridge 104A extends along a straight line. Further, as it can be seen, the staple field 110 may be curve-shaped.

10 [024] In some embodiments, the anvil 106A may be welded to the anvil cover 106B, and the anvil cover 106B may be pivoted at the inner tube 102B. In some embodiments, the anvil 106A may be pivotable relative to the cartridge 104A via the pivot pin 106C. The anvil 106A may include a plurality of slots on an inner surface of the anvil 106A facing the cartridge 104A. In some embodiments, upon application of a stapling action, one or more slots of the plurality of slots may be configured to engage with the plurality of staples held in the cartridge 104A to secure the plurality of staples on a body part subjected to surgery. The plurality of slots may be located within  
15 a slot field 112 defined on the inner surface of the anvil 106A.

[025] In some embodiments, the slot field 112 may be curve-shaped corresponding to the staple field 110. In some embodiments, the surgical stapler may include a handle (not shown in FIG. 1). The handle may be configured to trigger the stapling action through the reload assembly  
20 100, upon a user intervention.

[026] By way of providing a curve-shaped staple field 110, it is possible to perform stapling along a curved line on a body part, during a surgery, as shown in FIG. 13C. However, the overall shape of the reload assembly 100 remains along a straight-line. This allows usage of the reload assembly in Laparoscopic procedures.

25 [027] The reload assembly 100 may be adapted to be placed in a trocar of diameter ranges between 12 millimeter (mm) and 15 mm. Further, in some embodiments, the anvil 106A may extend along a straight corresponding to the cartridge 104A. This allows the reload assembly 100 of the surgical stapler to be laparoscopically introduced in the trocar of diameter ranging between 12mm and 15mm.

30 [028] Referring now to FIG. 3, a cross-section view of a part of a surgical stapler 300 including the reload assembly 100 is illustrated depicting initialization of the stapling action, in accordance with an embodiment of the present disclosure. Referring now to FIG. 4, another cross-section view of a part of a surgical stapler 300 including the reload assembly 100 is illustrated depicting initialization of the stapling action, in accordance with an embodiment of the present

disclosure. The stapling action may be initiated by squeezing the trigger (not shown in the FIGS. 3-4) which actuates a firing plate 302. It may be appreciated by a person skilled in the art, that the trigger may be the part of any handle of the surgical stapler for triggering the stapling action. As the trigger on handle is squeezed, it may push the firing plate 302 in a forward direction, as shown  
5 in FIG. 3. The firing plate 302 may include two ends: a cartridge end (upper) and an anvil end (lower). Further, the anvil end of the firing plate 302 moves horizontally over the anvil, and thus clamps the anvil to hold the tissue (blood vessel).

[029] As the firing plate 302 is pushed, the firing plate 302 may cause the anvil 106A to rotate about the pivot pin 106C, to thereby cause the one or more slots of the anvil 106A to engage  
10 with the plurality of staples held in the cartridge 104A. To this end, the firing plate 302 may include a plate end 602. Further, the anvil 106A may include an anvil end 502. FIG. 5 shows a perspective view of a part of the anvil 106A showing the anvil end 502. FIG. 6 shows a perspective view of a part of the firing plate 302 showing the plate end 602. The plate end 602 may engage with the anvil end 502 to cause the anvil 106A to rotate about the pivot pin 106C, to thereby cause the one or  
15 more slots of the anvil 106A to engage with the plurality of staples held in the cartridge 104A.

[030] Referring now to FIG. 7, a cross-section view of a part of a surgical stapler 300 including the reload assembly 100 is illustrated depicting initialization of the stapling action, in accordance with an embodiment of the present disclosure. Referring to FIG. 8, a magnified view of the part of a surgical stapler 300 including the reload assembly 100 is illustrated depicting  
20 initialization of the stapling action, in accordance with an embodiment of the present disclosure. The reload assembly 100 may include a wedge 704 configured to move between a first position and a second position under the stapling action. In the first position, the wedge may be positioned extreme towards cartridge side, and in the second position, the wedge may be positioned extreme towards handle side. In some embodiments, under the stapling action, the wedge 704 may be  
25 configured to cause to remove the plurality of staples from the cartridge 104A and cause the plurality of staples to engage with the one or more slots of the plurality of slots of the anvil 106A.

[031] The firing plate 302 may be coupled to the handle via one end and to the wedge 704 via the other end. Further, under the stapling action, the handle may be configured to move the wedge 704 from the first position to the second position. By way of an example, after the trigger  
30 get released (this has already been explained in detail in conjunction with FIG.3 and FIG.4), the trigger handle may be squeezed causing the firing plate to move further in forward direction. A cartridge end of the firing plate 302 may then come in contact with the wedge 704 and push the wedge 704 in forward direction, as shown in FIGS. 7-8.

[032] Further, FIG. 8, shows staple formation on a plurality of slots 804 of the anvil 106A, in accordance with an embodiment of the present disclosure. This figure shows a plurality of staples 802 before formation 802A and after formation 802B. Under the stapling action, the wedge 704 may be configured to cause to remove the plurality of staples 802 from the cartridge 104A and cause the plurality of staples to engage with the one or more slots of the plurality of slots of the anvil 106A. By way of an example, due to the inclined surface of the wedge 704 and a plurality of pushers 706, the wedge 704 may push the pushers 706 in a downward direction (to thereby cause the staples 702 to move in downward direction) as it travels forward. The staples then bend in the anvil pockets (i.e., in the one or more slots of the plurality of slots 804 of the anvil 106A) and seal the tissue.

[033] In some embodiments, the plurality of staples 702 within the staple field 110 may be distributed in at least three rows defined along the length of the cartridge 104A to prevent leakage. Further, the plurality of staples 702 within the staple field 110 may be aligned parallel to each other. Further, the plurality of staples 702 within the staple field 110 may also be aligned parallel to the length of the cartridge 104A.

[034] The stapling action may be initiated by squeezing the trigger (not shown in the FIGS. 3-4) which actuates a firing plate 302. It may be appreciated by a person skilled in the art, that the trigger may be the part of any handle of the surgical stapler for triggering the stapling action. As the trigger on handle is squeezed, it may push the firing plate 302 in a forward direction, as shown in FIG. 3. The firing plate 302 may include two ends: a cartridge end (upper) and an anvil end (lower). Further, the anvil end of the firing plate 302 moves horizontally over the anvil, and thus clamps the anvil to hold the tissue (blood vessel).

[035] As the firing plate 302 is pushed, the firing plate 302 may cause the anvil 106A to rotate about the pivot pin 106C, to thereby cause the one or more slots of the anvil 106A to engage with the plurality of staples held in the cartridge 104A. To this end, the firing plate 302 may include a plate end 602. Further, the anvil 106A may include an anvil end 502. FIG. 5 shows a perspective view of a part of the anvil 106A showing the anvil end 502. FIG. 6 shows a perspective view of a part of the firing plate 302 showing the plate end 602. The plate end 602 may engage with the anvil end 502 to cause the anvil 106A to rotate about the pivot pin 106C, to thereby cause the one or more slots of the anvil 106A to engage with the plurality of staples held in the cartridge 104A.

[036] Referring now to FIG. 9, a cross-section view of a part of the surgical stapler 300 including the reload assembly 100 is illustrated depicting completion of the stapling action, in accordance with an embodiment of the present disclosure. Referring to FIG. 10, another cross-section view of a part of the surgical stapler 300 including the reload assembly 100 is illustrated

depicting completion of the stapling action, in accordance with an embodiment of the present disclosure. After the stapling is done, a retraction knob in the trigger (not shown in FIG. 9) is pulled back by the user (for example, by a surgeon) which may cause firing plate 302 to move back (as shown by arrows). As the firing plate 302 goes back, it may no longer hold the anvil 106A in the clamping position.

5 [037] The reload assembly 100 may further include a leaf spring 1002 that may be fixed in between the anvil 106A and the cartridge 104A. The leaf spring 1002 between the anvil 106A and the cartridge 104A may cause the anvil 106A to swing back to its original position, as shown in the FIG. 10. After the firing plate 302 reaches to the original position, the reload assembly 100 may be unloaded by engaging the release mechanism in the trigger (not shown in FIG. 10). Later, the surgeon may cut the required vessel portion using laparoscopic scissors.

10 [038] Referring now to FIG. 11, a bottom view of an inner surface of a cartridge 1104A (corresponding to the cartridge 104A) of a reload assembly is illustrated, in accordance with another embodiment of the present disclosure. In some embodiments, the plurality of staples 1102 within the staple field 1104 may be aligned substantially tangential (curved line) to the curve of the curve-shaped staple field. Further, the plurality of slots on the inner surface of the anvil may be aligned substantially tangential to the curve of the curve-shaped slot field, and the curve of the curve-shaped staple field 1104 may be equivalent to the curve of the curve-shaped slot field.

15 [039] Referring now to FIG. 12, a process 1200 of operating the reload assembly 100 is illustrated in accordance with an embodiment of the present disclosure. The process 1200 as shown in FIG. 12 may began with inserting the reload assembly 100 into the handle of the surgical stapler and may be terminated with unloading the reload assembly 100 from the handle of the surgical stapler, after completing the stapling.

20 [040] At step 1202, the reload assembly 100 may be inserted in the surgical stapler to couple the reload assembly 100 with a handle of the surgical stapler. At step 1204, the reload assembly 100 may be clamped to the rest of the surgical stapler (i.e. including the handle). At step 1206, the surgical stapler may be fired to cause the surgical stapler to apply one or more staples on a body part, during a surgery. At step 1208, upon the completion of staple action, the firing plates may start receding. At step 1210. The reload assembly may be unloaded from the rest of the surgical stapler.

25 [041] The present disclosure discusses a reload assembly for a surgical stapler. The reload assembly provides a curved staple line so that the surgical stapler may be laparoscopically introduced into a 12 mm or 15 mm trocar. The above-mentioned technique may provide a time-effective solution which requires a shorter recovery time and may have a lower risk of infections.

Further, the technique may provide a knifeless design of the reload assembly that gives a surgeon the advantage to cut the tissue/vessel to his/her required length after stapling. Furthermore, the design of the staple (particularly, the reload assembly) can be modified to be used with Medtronic or Ethicon Handle designs.

5           **[042]**   It is intended that the disclosure and examples be considered as exemplary only, with a true scope and spirit of disclosed embodiments being indicated by the following claims.

**WE CLAIM:**

1. A surgical stapler comprising:

a reload assembly (100) comprising:

a cartridge (104A) configured to temporarily hold a plurality of staples within a staple field (110) defined on an inner surface of the cartridge (104A) along the length of the cartridge (104A), wherein the length of the cartridge (104A) extends along a straight line, and wherein the staple field (110) is curve-shaped; and

an anvil (106A) pivotable relative to the cartridge (104A), wherein the anvil (106A) comprises a plurality of slots on an inner surface of the anvil (106A) facing the cartridge (104A), wherein upon application of a stapling action, one or more slots of the plurality of slots are configured to engage with the plurality of staples held in the cartridge (104A) to secure the plurality of staples on a body part subjected to surgery; and

a handle for triggering the stapling action through the reload assembly (100), upon a user intervention.

2. The surgical stapler as claimed in claim 1, wherein the surgical stapler is adapted to be placed in a trocar, wherein the diameter of the trocar ranges between 12 milli meter (mm) and 15 mm.

3. The surgical stapler as claimed in claim 1, wherein the plurality of slots is located within a slot field (112) defined on the inner surface of the anvil (106A), and wherein the slot field (112) is curve shaped corresponding to the staple field (110).

4. The surgical stapler as claimed in claim 1, wherein the plurality of staples within the staple field (110) is distributed in at least three rows defined along the length of the cartridge (104A).

5. The surgical stapler as claimed in claim 1, further comprising:

a wedge (604) configured to move between a first position and a second position under the stapling action, wherein under the stapling action, the wedge (604) is configured to cause to remove the plurality of staples from the cartridge (104A) and cause the plurality of staples to engage with the one or more slots of the plurality of slots of the anvil (106A); and

a firing plate (302) having a first end and a second end, wherein the firing plate (302) is coupled to the handle via the first end and to the wedge (604) via the second edge, wherein under

the stapling action, the handle is configured to move the wedge (604) from the first position to the second position.

6. The surgical stapler as claimed in claim 1,

wherein the plurality of staples within the staple field is aligned parallel to each other,  
and

wherein the plurality of staples within the staple field is aligned parallel to the length of the cartridge (104A).

7. The surgical stapler as claimed in claim 3,

wherein the plurality of staples within the staple field is aligned substantially tangential to the curve of the curve-shaped staple field; and

wherein the plurality of slots on the inner surface of the anvil (106A) is aligned substantially tangential to the curve of the curve-shaped slot field, and wherein the curve of the curve-shaped staple field is equivalent to the curve of the curve-shaped slot field.

8. A reload assembly (100) for a surgical stapler, the reload assembly (100) comprising:

a cartridge (104A) configured to temporarily hold a plurality of staples within a staple field defined on an inner surface of the cartridge (104A) along the length of the cartridge (104A), wherein the length of the cartridge (104A) extends along a straight line, and wherein the staple field is curve shaped; and

an anvil (106A) pivotable about the cartridge (104A), wherein the anvil (106A) comprises a plurality of slots on an inner surface of the anvil (106A) facing the cartridge (104A), wherein upon application of a stapling action, one or more slots of the plurality of slots are configured to engage with the plurality of staples held in the cartridge (104A) to secure the plurality of staples on a body part subjected to surgery.

**Dated this 24<sup>th</sup> day of June 2022**

***-- Digitally Signed--***

**Robin Koshy Varghese**  
**(INPA No: 3705)**

Head, IPR Dept.,  
L&T Technology Services Limited,  
DLF 3rd Block, 2nd Floor,  
Manapakkam, Chennai - 600089.

**ABSTRACT**

**A SURGICAL STAPLER**

A surgical stapler (300) is disclosed. The surgical stapler (300) may include a reload assembly (100) which may further include a cartridge (104A) configured to temporarily hold a plurality of staples within a staple region defined on an inner surface of the cartridge (104A) along the length of the cartridge (104A). The length of the cartridge (104A) extends along a straight line, and the staple region is curve-shaped. The reload assembly (100) may further include an anvil (106A) pivotable relative to the cartridge (104A). The anvil (106A) includes a plurality of cam profiles on an inner surface of the anvil (106A) facing the cartridge (104A). Upon application of a stapling action, one or more cam profiles of the plurality of cam profiles are configured to engage with the plurality of staples held in the cartridge (104A) to secure the plurality of staples on a body part subjected to surgery.

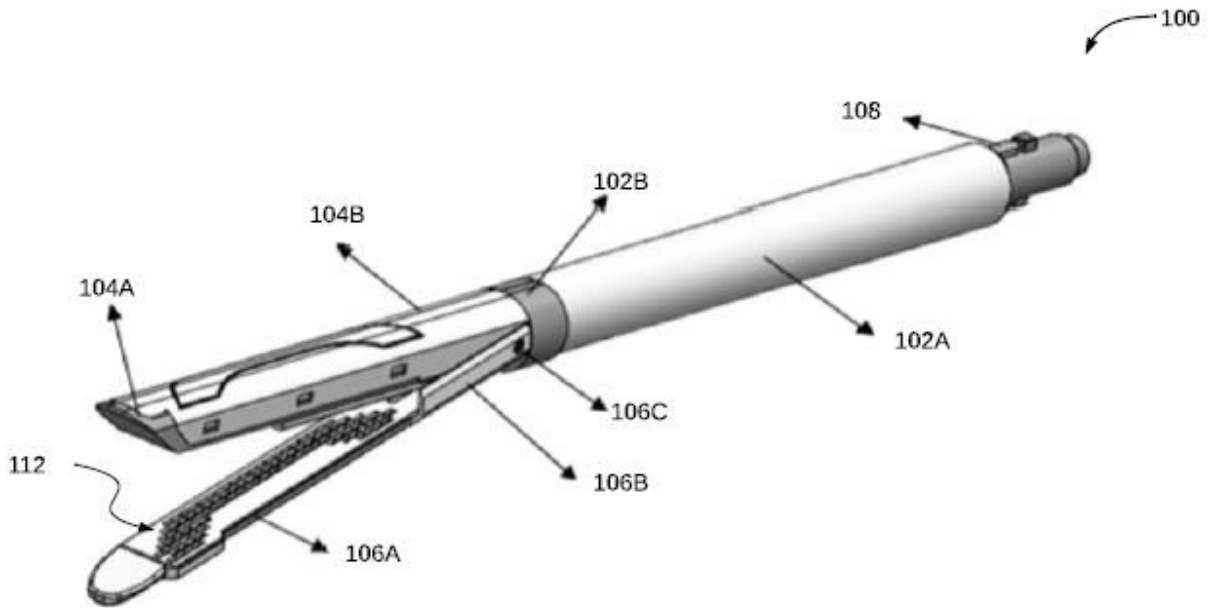

**FIG . 1**

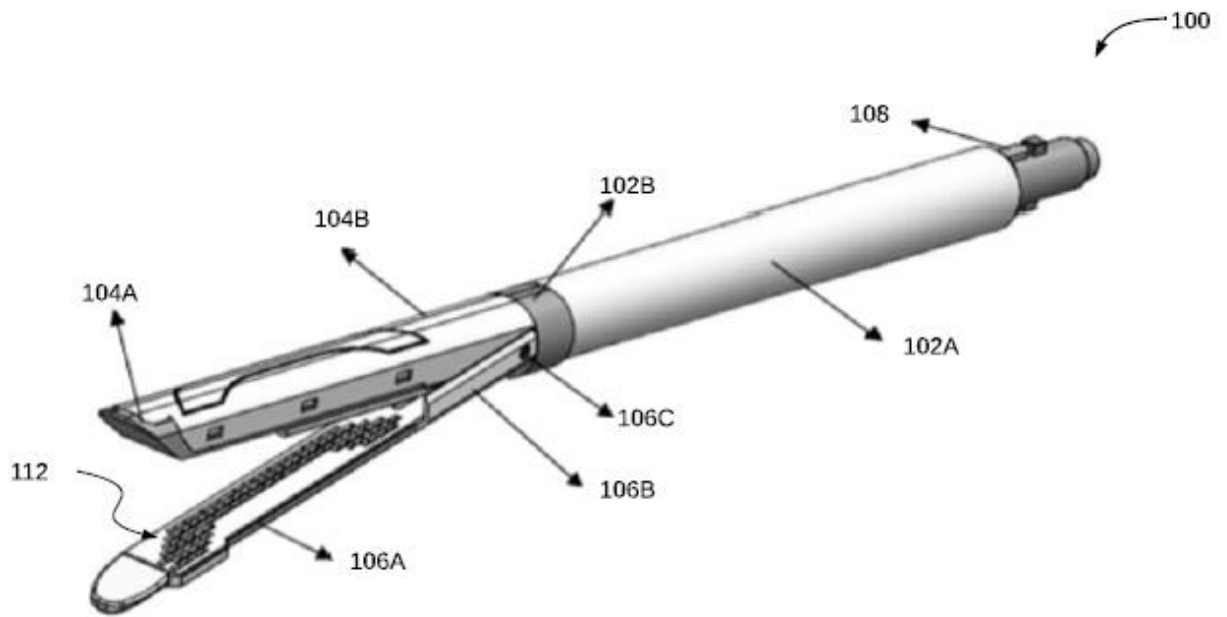

**FIG . 1**

-- Digitally Signed--

Robin Koshy Varghese  
(INPA No: 3705)  
Head, IPR Dept.,  
L&T Technology Services Limited,  
DLF 3rd Block, 2nd Floor,  
Manapakkam, Chennai - 600089.



FIG . 2A

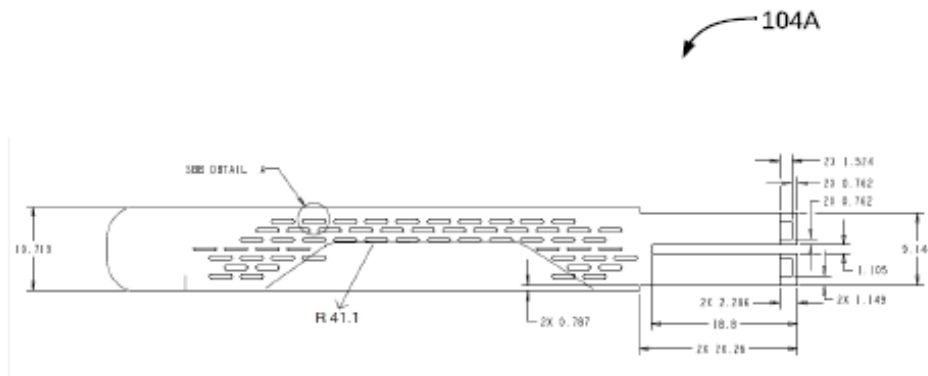
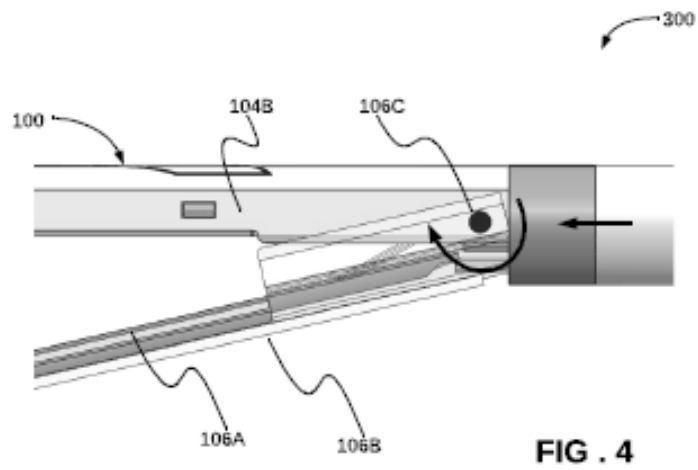
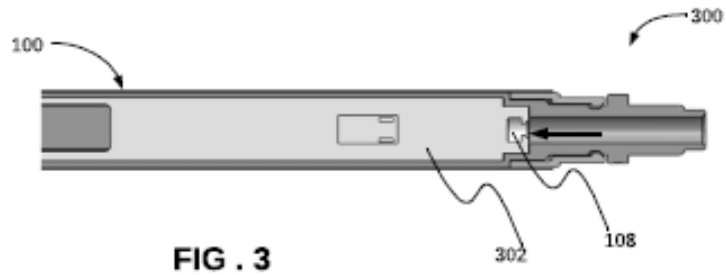

FIG . 2B

-- Digitally Signed--

Robin Koshy Varghese  
(INPA No: 3705)  
Head, IPR Dept.,  
L&T Technology Services Limited,  
DLF 3rd Block, 2nd Floor,  
Manapakkam, Chennai - 600089.



-- Digitally Signed--

Robin Koshy Varghese  
(INPA No: 3705)  
Head, IPR Dept.,  
L&T Technology Services Limited,  
DLF 3rd Block, 2nd Floor,  
Manapakkam, Chennai - 600089.

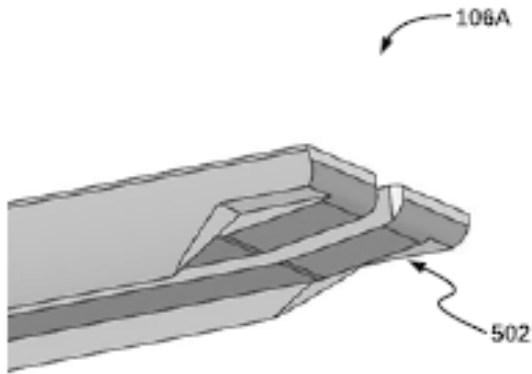

**FIG . 5**

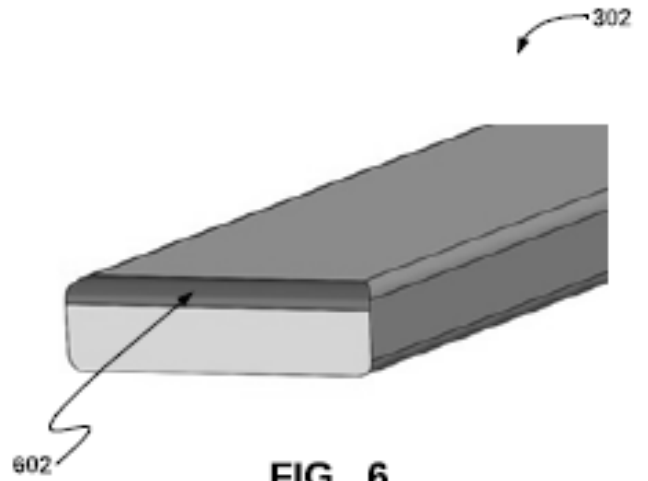

**FIG . 6**

-- Digitally Signed--

Robin Koshy Varghese  
(INPA No: 3705)  
Head, IPR Dept.,  
L&T Technology Services Limited,  
DLF 3rd Block, 2nd Floor,  
Manapakkam, Chennai - 600089.

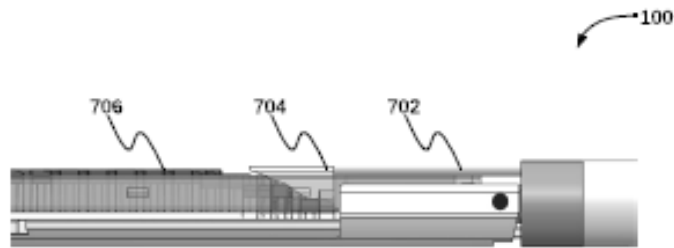

**FIG . 7**

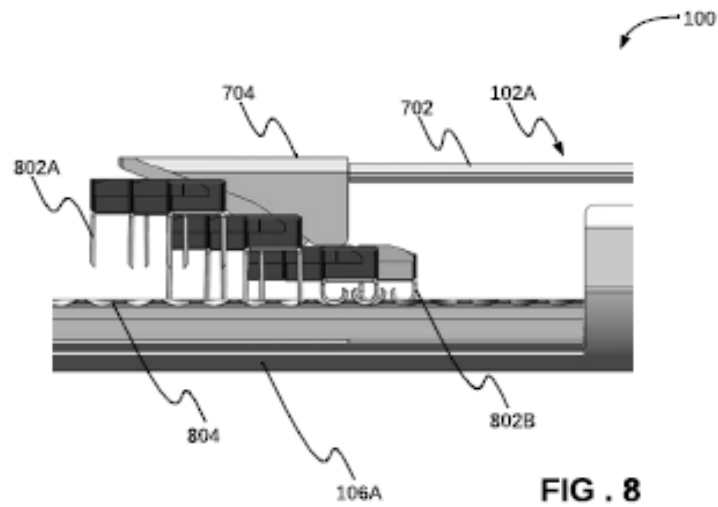

**FIG . 8**

-- Digitally Signed--

Robin Koshy Varghese  
(INPA No: 3705)  
Head, IPR Dept.,  
L&T Technology Services Limited,  
DLF 3rd Block, 2nd Floor,  
Manapakkam, Chennai - 600089.

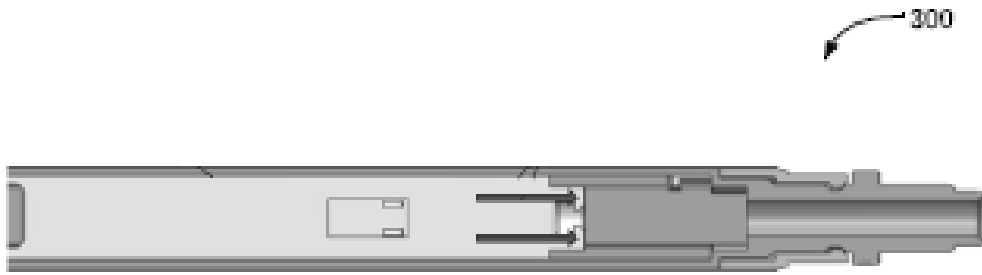

**FIG . 9**

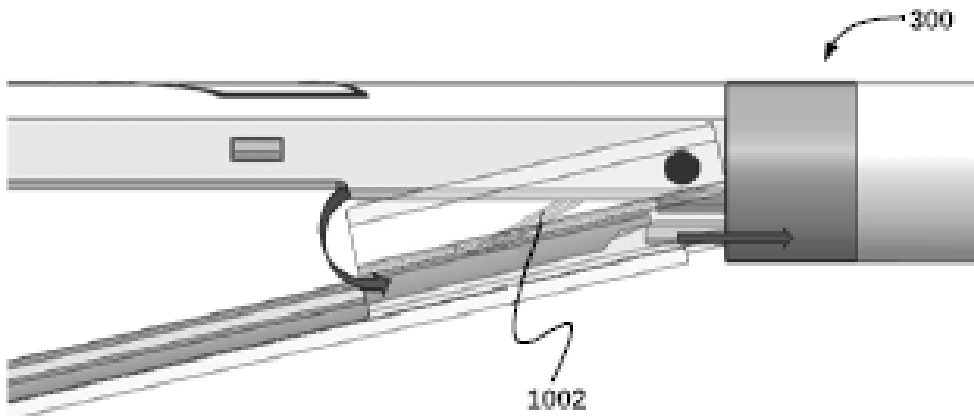

**FIG . 10**

-- Digitally Signed--

Robin Koshy Varghese  
(INPA No: 3705)  
Head, IPR Dept.,  
L&T Technology Services Limited,  
DLF 3rd Block, 2nd Floor,  
Manapakkam, Chennai - 600089.

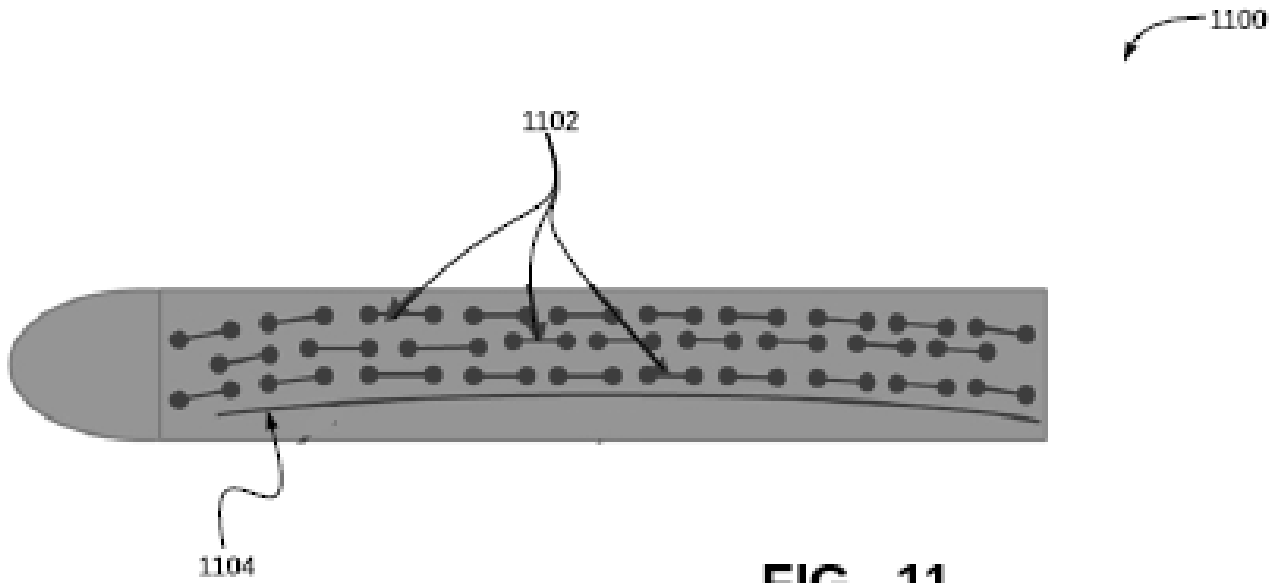

**FIG . 11**

-- Digitally Signed--

Robin Koshy Varghese  
(INPA No: 3705)  
Head, IPR Dept.,  
L&T Technology Services Limited,  
DLF 3rd Block, 2nd Floor,  
Manapakkam, Chennai - 600089.

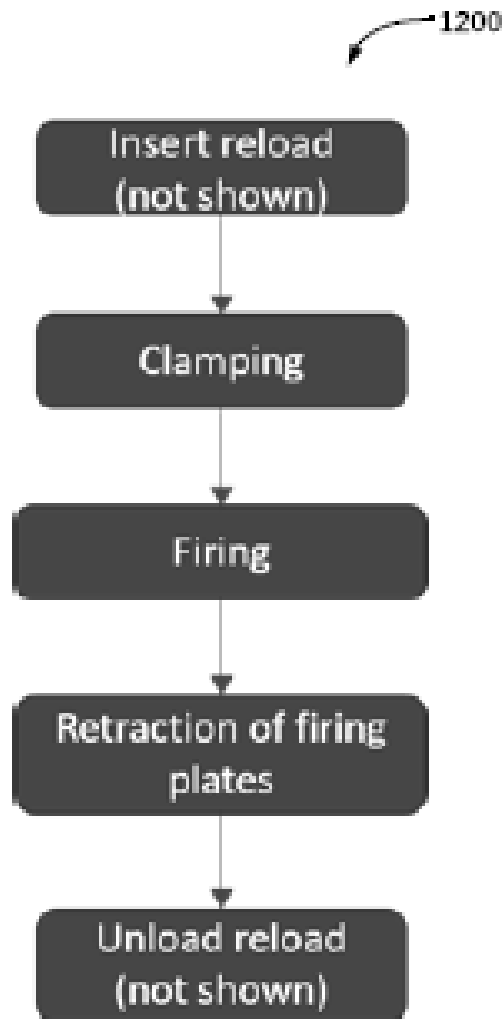

**FIG . 12**

-- Digitally Signed--

Robin Koshy Varghese  
(INPA No: 3705)  
Head, IPR Dept.,  
L&T Technology Services Limited,  
DLF 3rd Block, 2nd Floor,  
Manapakkam, Chennai - 600089.

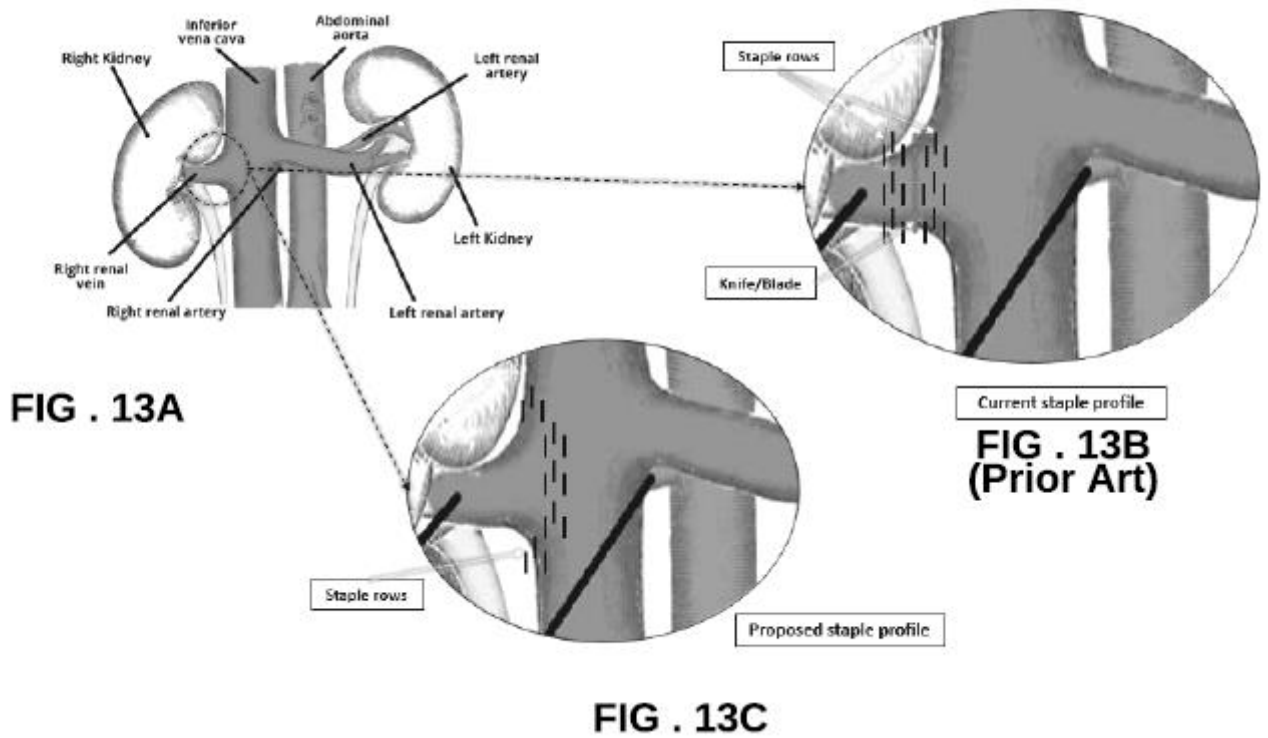

-- Digitally Signed--

Robin Koshy Varghese  
(INPA No: 3705)  
Head, IPR Dept.,  
L&T Technology Services Limited,  
DLF 3rd Block, 2nd Floor,  
Manapakkam, Chennai - 600089.