

(12) Indian Patent Application

(21) Application Number: 202141039418

(22) Filing Date: 31/08/2021 (43) Publication Date: 03/03/2023

(71) Applicant(s): L&T TECHNOLOGY SERVICES LIMITED

(72) Inventor(s): Dubey, Abhishek Shashikumar

(51) International Classifications: G01N 21/51 G01N 21/88 G01N 21/64 G01N 33/28 G01N 21/78

(54) Title: SYSTEM AND METHOD FOR EVALUATION OF OIL

(57) Abstract: The present invention relates a system and method to evaluate oil samples. The method comprises placing a glass cuvette configured to hold oil sample into a cuvette slot. The method further comprises adjusting a position of the glass cuvette in the cuvette slot using a screw arrangement. The screw arrangement is configured to allow the glass cuvette to move vertically into the cuvette slot. The method comprise controlling wavelength of light produced by a LED light source such that light of a first and a second wavelength pass through the oil sample, within a pre-determined interval of time, with each turn of the screw arrangement. Thereafter, radiation, produced by the light after passing through the oil sample, is detected over the time period, for each position of the glass cuvette. Thereafter, an image of each of the detected radiation pattern is generated and processed to evaluate the oil sample.

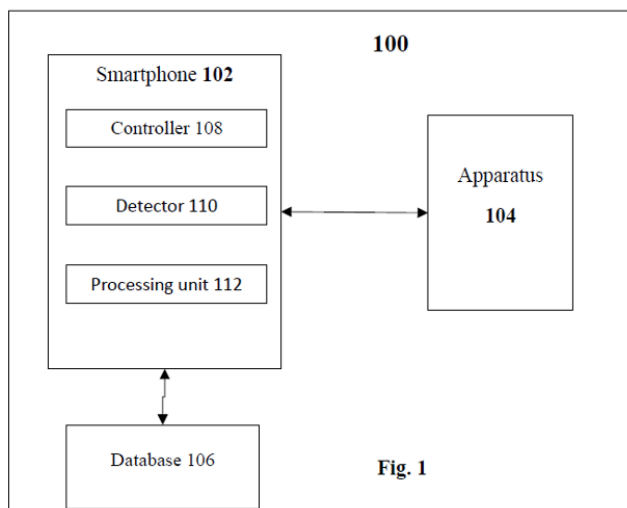

FORM 2

THE PATENTS ACT 1970
(39 OF 1970)
&
The Patent Rules, 2003
Complete Specification
(See Section 10 and Rule 13)

1. TITLE OF THE INVENTION

SYSTEM AND METHOD FOR EVALUATION OF OIL

2. APPLICANT(S)

(a) NAME : **L&T TECHNOLOGY SERVICES LIMITED**

(b) NATIONALITY : **INDIAN**

(c) ADDRESS : **DLF IT SEZ Park, 2nd Floor – Block 3**

1/124, Mount Poonamallee Road,

Ramapuram, Chennai – 600 089,

INDIA.

3. PREAMBLE TO THE DESCRIPTION

COMPLETE

The following specification describes the invention
and the manner in which it is to be performed

DESCRIPTION

TECHNICAL FIELD

[0001] The present subject matter described herein, in general, discloses system and method to evaluate the oil sample using smartphone-based technique.

BACKGROUND

[0002] A transformer is an integral as well as one of the costliest equipment of the power system, hence its reliable operation is of utmost importance for power grid stability. If a transformer goes out, it leads to heavy capital and operational losses. Transformer oil is the blood equivalent for the transformer. Its primary function is to keep it electrically insulated and to maintain the transformer's internal temperature by cooling it. Throughout its continuous operation, transformer's oil gets both degraded and contaminated. Internal arcing in the transformer and incipient faults lead to the formation of aromatic compounds of heavier molecular weight. If it is not checked on time, this could result in the catastrophic failure either by insulation failure or explosion in the worst case. Similarly, transformer oil gets contaminated if the ingress protection is compromised. Dust and moisture seep in, moisture reduces its insulation level and dust along with oil residuals forms the sludge affecting the cooling system of the transformer. Over 70% of the transformer faults are related to the transformer oil. So timely inspection of transformer oil can help with the preventive maintenance of it.

[0003] Various techniques are available for monitoring and various commercial products are available. An optical density-based sensor may be used to analyse the transformer oil. The sensor converts optical signals to electrical impedance. Further, optical sweep frequency response analysis may be used to monitor changes in response with each wavelength. Furthermore, the dielectric constant based technique is also used, in which relative permittivity of oil is compared to that of free space permittivity. Interleaved capacitors were used to sense the same.

[0004] However, there is need of techniques which are more cost effective and simpler ways for the in-situ assessment of oil quality.

SUMMARY

[0005] The present disclosure overcomes one or more shortcomings of the prior art and provides additional advantages discussed throughout the present disclosure. Additional features and advantages are realized through the techniques of the present disclosure. Other embodiments and aspects of the disclosure are described in detail herein and are considered a part of the claimed disclosure.

[0006] In one non-limiting embodiment of the present disclosure a system to evaluate oil samples is proposed. The system comprises an apparatus comprising: a housing having a horizontal tubular passage extending from a distal end to a proximal end of the housing, wherein the horizontal tubular passage is configured to allow passage of light from the distal end to the proximal end. A LED light source fixed at the distal end of the housing, wherein the LED light source is configured to produce light of plurality of wavelengths. Further, a cuvette slot at centre of the housing, configured to hold a glass cuvette, wherein the glass cuvette is configured to hold oil sample to be evaluated. A screw arrangement attached at bottom of the cuvette slot to allow the glass cuvette to move vertically into the cuvette slot for vertical scanning of the oil sample. The system further comprises a smart phone operatively connected to said apparatus such that the proximal end of the housing of the apparatus is attached to camera of the smart phone. The smart phone comprises a controller configured to: allow the screw arrangement to change vertical position of the glass cuvette, within the cuvette slot; and control the wavelength of the light produced by the LED light source such that light of a first wavelength and light a second wavelength pass through the oil sample, within a pre-determined interval of time, with each turn of the screw arrangement such that entire oil sample is scanned. Further, a detector configured to detect an output radiation produced by the light of the first wavelength and the light of the second wavelength after passing through the oil sample, over the time period, for each position of the glass cuvette. The smartphone further comprises a processing unit configured to generate an image of each of the detected radiation pattern, and process the captured images to evaluate the oil sample.

[0007] In another non-limiting embodiment of the present disclosure said glass cuvette is a cuboidal vessel made of quartz, to hold the oil sample and is placed in optical path between the LED light source and the detector.

[0008] In yet another non-limiting embodiment of the present disclosure said detector comprises: a lens configured to converge the radiation detected by the detector, an optical filter configured to disperse the radiation into RGB component, and a plurality of CMOS sensors each corresponding to a RGB wavelength configured to detect intensity of light detected by the detector.

[0009] In yet another non-limiting embodiment of the present disclosure, the processing unit is configured to process the captured images to determine optical transmittance, scattering index and optical absorbance of the oil sample, wherein the optical transmittance is calculated by $T = I/I_0$, T represents intensity in a transmittance region of the radiation pattern. The scattering index is calculated as integral sum of light intensity in a scattering region of the radiation pattern. The optical absorbance is calculated by $A = \ln(I/I_0)$, I represents the intensity in the sample oil and I_0 is the intensity of a blank sample.

[0010] In yet another non-limiting embodiment of the present disclosure, a method for evaluating oil samples is disclosed. The method comprises placing a glass cuvette configured to hold an oil sample into a cuvette slot present at centre of a housing having a horizontal tubular passage extending from a distal end to a proximal end of the housing, wherein the horizontal tubular passage is configured to allow passage of light from the distal end to the proximal end. The method further recites adjusting a position of the glass cuvette in the cuvette slot using a screw arrangement attached at bottom of the cuvette slot, wherein the screw arrangement is configured to allow the glass cuvette to move vertically into the cuvette slot for vertical scanning of the oil sample. Further, controlling wavelength of light produced by a LED light source such that light of a first wavelength and light a second wavelength pass through the oil sample, within a pre-determined interval of time, with each turn of the screw arrangement such that entire oil sample is scanned. The method further recites detecting an output radiation, at a detector, produced by the light of the first wavelength and the light of the second wavelength after passing through the oil sample, over the time period, for each position of the glass cuvette, generating an image of each of the detected radiation pattern, and processing the captured images to evaluate the oil sample.

[0011] In yet another non-limiting embodiment of the present disclosure, said glass cuvette is a cuboidal vessel made of quartz, to hold the oil sample and is placed in optical path between the LED light source and the detector.

[0012] In yet another non-limiting embodiment, the present disclosure describes that detecting the output radiation comprises: converging the radiation detected by the detector, dispersing the radiation into RGB component, and detecting intensity of light detected by the detector using a plurality of CMOS sensors each corresponding to a RGB wavelength of detected light.

[0013] In yet another non-limiting embodiment of the present disclosure recites processing the captured images to determine optical transmittance, scattering index and optical absorbance of the oil sample. The optical transmittance is calculated by $T = I/I_0$, and wherein T represents intensity in a transmittance region of the radiation pattern. The scattering index is calculated as integral sum of light intensity in a scattering region of the radiation pattern. The optical absorbance is calculated by $A = \ln(I/I_0)$, wherein I represents the intensity in the sample oil and I_0 is the intensity of a blank sample.

[0014] In yet another non-limiting embodiment of the present disclosure recites evaluating the determined optical transmittance, scattering index and optical absorbance, based on degree of dilution of said oil sample in isooctane and calibration data, to determine at least colour ratio of the oil sample, concentration of oil sludge floc, density profile of the oil sample, and turbidity of the oil sample.

OBJECTIVES OF THE INVENTION

[0015] An objective of the present invention is to provide a system and a method for evaluating oil samples in cost-effective and simple manner.

[0016] Another objective of the present invention is to provide a system and method for In-situ monitoring with the timely insights for the preventive maintenance of transformer.

BRIEF DESCRIPTION OF THE DRAWINGS

[0017] The accompanying drawings, which are incorporated in and constitute a part of this disclosure, illustrate exemplary embodiments and, together with the description, serve to explain the disclosed embodiments. In the figures, the left-most digit(s) of a reference number identifies the figure in which the reference number first appears. The same numbers are used throughout the figures to reference like features and components. Some embodiments of system and/or methods in accordance with embodiments of the present subject matter are now described, by way of example only, and with reference to the accompanying figures, in which:

[0018] Fig. 1 illustrates a block diagram of a system to evaluate oil samples, in accordance with an embodiment of the present subject matter.

[0019] Fig. 2 illustrates an apparatus of the system to evaluate oil samples, in accordance with an embodiment of the present subject matter.

[0020] Fig. 3 illustrates an exemplary flow of photons passing through an oil sample, in accordance with an embodiment of the present subject matter.

[0021] Fig. 4a-4b illustrate exemplary radiation patterns of output radiations, in accordance with an embodiment of the present subject matter.

[0022] Fig. 5 is a flow diagram illustrating a method to evaluate oil samples, in accordance with an embodiment of the present subject matter.

[0023] It should be appreciated by those skilled in the art that any block diagrams herein represent conceptual views of illustrative systems embodying the principles of the present subject matter. Similarly, it will be appreciated that any flow charts, flow diagrams, state transition diagrams, pseudo code, and the like represent various processes which may be substantially represented in computer readable medium and executed by a computer or processor, whether or not such computer or processor is explicitly shown.

DETAILED DESCRIPTION

[0024] In the present document, the word “exemplary” is used herein to mean “serving as an example, instance, or illustration.” Any embodiment or implementation of the present subject-matter described herein as “exemplary” is not necessarily to be construed as preferred or advantageous over other embodiments.

[0025] While the disclosure is susceptible to various modifications and alternative forms, specific embodiment thereof has been shown by way of example in the drawings and will be described in detail below. It should be understood, however that it is not intended to limit the disclosure to the particular forms disclosed, but on the contrary, the disclosure is to cover all modifications, equivalents, and alternatives falling within the scope of the disclosure.

[0026] The terms “comprises”, “comprising”, “include(s)”, or any other variations thereof, are intended to cover a non-exclusive inclusion, such that a setup, system or method that comprises a list of components or steps does not include only those components or steps but may include other components or steps not expressly listed or inherent to such setup or system or method. In other words, one or more elements in a system or apparatus preceded by “comprises... a” does not, without more constraints, preclude the existence of other elements or additional elements in the system or apparatus.

[0027] In the following detailed description of the embodiments of the disclosure, reference is made to the accompanying drawings that form a part hereof, and are shown by way of illustration of specific embodiments in which the disclosure may be practiced. These embodiments are described in sufficient detail to enable those skilled in the art to practice the disclosure, and it is to be understood that other embodiments may be utilized and that changes may be made without departing from the scope of the present disclosure. The following description is, therefore, not to be taken in a limiting sense.

[0028] The present invention will be described herein below with reference to the accompanying drawings. In the following description, well known functions or constructions are not described in detail since they would obscure the description with unnecessary detail.

[0029] The present disclosure recites a system to evaluate oil samples. The system uses smartphone camera to evaluate the oil samples. Since, today smartphone technology has penetrated every sphere of our society, thus the smartphone with technological advancements could be leveraged to produce In-situ and cost-effective solutions for analysing the transformer oil. Transformer's oil can give many insights on transformers condition. The proposed system allows testing of the oil sample on the field itself with an instrument at a fraction of the cost of the existing techniques.

[0030] CMOS sensor, an upgrade to the photodiode has revolutionized the camera technology. A person carries 5 to 6 of them with him in his smartphone as the camera. These camera sensors are used for designing sensing devices for various fields, be it for biotechnological purposes or electrochemical sensing. The latest smartphones are increasingly seen as handheld computers owing to the capabilities which are now offered by them. For a densely populated country like India, scarcity of resources has increased the demand for point-of-care test techniques. To cater to the need essential prerequisites for such testing device is being portable, inexpensive, and connectivity with the internet is a must. A smartphone is a complete package due to its processing, visualization, connectivity, and image capturing capabilities. According to the present disclosure, a smartphone opens up of being an optical platform, to be used as a hand-held scientific tool available at the site at a fraction of cost.

[0031] Referring to figure 1, a system 100 to evaluate the oil samples is shown. The system 100 may comprise a smartphone 102 and a smartphone attachment 104 (herein referred as “an apparatus 104”) and a database 106. The apparatus has cuvette slot to hold the oil sample and have a light source with produces light of various wavelengths. When light passes through the oil sample, the smartphone captured the images of radiation produced by the light being passing through the oil sample. The smartphone analyses these images to evaluate the properties of the oil.

[0032] According to an embodiment of the present disclosure, the smartphone 102 may comprise a controller 108, a detector 110 and a processing unit 112, which are communicatively coupled with each other and the apparatus 104. The detailed structure of apparatus 104 is shown in figure 2 discussed below.

[0033] The apparatus 104 comprises a housing 202 having a horizontal tubular passage extending from a distal end 204 to a proximal end 206 of the housing 202. The horizontal tubular passage is configured to allow passage of light from distal end 204 to the proximal end 206. The apparatus further comprises a LED light source 208 fixed at the distal end 204 of the housing 202. The LED light source 208 is configured to produce light of plurality of wavelengths. A cuvette slot 210 at center of the housing 202 is configured to hold a glass cuvette 212. The glass cuvette 212 is configured to hold oil sample to be evaluated. Further, a screw arrangement 214 is attached at bottom of the cuvette slot 210 to allow the glass cuvette 212 to move vertically into the cuvette slot 210 for vertical scanning of the oil sample.

[0034] According to an exemplary embodiment, the apparatus 104 may further comprises a holder 216 for the LED light source 208 and a double convex lens 218. The apparatus Camera opening 220 at the proximal end 206 to attach the smartphone 102. The apparatus 104 may further comprises a PCB 222 containing a microcontroller (ATmega-328P) and voltage regulator (AMS1117) for various operations of the apparatus and its elements. Further, a rubber padding (Rubber gasket) 224 is provided at the proximal end 206 of the housing 202. Furthermore, Gecko tape masking 226 is also provided at the proximal end. Furthermore, a serial port 228 for power and communication with the smartphone 102 is also provided.

[0035] According to an exemplary embodiment of the present disclosure, the system 100 uses the principles of optical absorbance, colour ratio of sample for evaluating the oil sample, as discussed below.

[0036] When light passes through a medium, it is absorbed to an extent based on the optical properties of that medium. This could be explained using Beer-Lambert's law which states that the amount of light emerging from a sample is diminished depending upon three parameters. One is the concentration of absorbing material within the sample, the second is the linear optical path length of the medium, and the third is the probability of absorption. Along with the degradation of oil, there is also a change in its colour and hence the proportional change in absorbance. It is known that oil colour becomes darker with degradation and hence the value of the absorbance value increases. A 450 nm LED is used as the light source 208 to detect the absorbance. Smartphone's camera is used as the photodetector. However, absorbance is also affected by the suspended

particles present in the sample, in the form of dust or oil flocs. They either absorb it or disperse radiation leading to the overestimation of values. Correction for their contribution to the optical absorbance is done using the principle of scattering and transmittance for tracking colloids and suspensions in the sample.

[0037] Further, in a liquid mixture, there are two kinds of suspended particles. One which gradually settles down owing to their high particle size, known as suspension and colloids which remain afloat as per the Brownian motion due to their smaller particle size. Now the quantification of suspended particles is important for two reasons. First to cancel their effect from the optical absorbance and secondly to quantify the content of oil floc in the sample. To nullify the effect of colloids on absorbance value we use the transmittance of light in the medium, which is nothing but the anti-Log of absorbance in the given medium for the given wavelength. A 630 nm LED is used as the light source 208 as they show minimal absorbance in the oil medium. Now as they pass through the medium a part of the radiation is being scattered by the colloids. So, there is a difference between radiation emitted and radiation absorbed. This difference could be used to rectify the absorbance value calculated from the 450 nm radiation.

[0038] Further, Transmittance is measured just as the intensity of light reaching the detector and the degree of scattered radiation is measured by measuring the illumination produced due to the subsequent scattering of light. The data from both the sampling is then used to mitigate the effect of suspended particles on the absorbance values measured through 450 nm LED. Using the differential approach contribution from both colloidal as well as suspended particulates towards the overall turbidity can be measured individually and hence amount of oil sludge floc could be quantified. Using the same vertical quantification of suspended particulates will also provide us with the vertical density profile of the transformer oil. Fig. 3 illustrates an exemplary flow of the photon through the sample to show the effect of scattering and absorbance of the light passing through the sample.

[0039] Now again referring to fig. 1, for evaluation of the oil, the oil sample is collected from the field and is diluted with isooctane with required concentration. Then the solution is kept in the glass cuvettes for 1 hour of time as the settling period. The apparatus 104 is attached to the smartphone's camera. Apparatus surface has a layer of gecko tape to adhere the smartphone's

camera to the surface. Further, the apparatus 104 is connected with the smartphone 102 using a USB cable. The apparatus 104 is powered and controlled through the smartphone itself, using the serial protocol.

[0040] Thereafter, the sample present in the glass cuvette 212 is inserted into the apparatus 104 and covered through a cap (not shown in figure). As the sample has to be scanned vertically so the position of the glass cuvette is adjusted using the screw arrangement 214. The adjustment could be done in steps and the number of turns of screw for the adjustments could be provided as an input to an application in the smartphone 102. After that the smartphone 102 initiates an automatic process in which it records three optical parameters of sample in a span of predefined time period, which may be defined as 10 seconds. According to an embodiment, the controller 108 may allow the screw arrangement 214 to change vertical position of the glass cuvette 212, within the cuvette slot 210.

[0041] In order to capture the optical parameters, light is produced by the LED light source 208 and passed through the sample. According to an embodiment, the light source 208 in the present disclosure is unlike a spectrophotometer or a colorimeter which uses a white light source. The system 100 uses a LED as the light source 208. Depending upon the wavelength required, LEDs of respective substrate material could be used to produce them. For the requirement of multiple wavelengths, socket type LED could be used which can easily be replaced as per requirement. An RGB LED comprises of three substrate materials that can produce a wavelength of three ranges and can be controlled independently. Also, for obtaining radiation of the desired wavelength, it's easy to get LED of a particular wavelength than getting an optical filter. The reason for the same is the manufacturing process. At the same time, the spectrum of the radiation produced is quite narrow and near to the desired wavelength in LED if we compare it with the optical filter used for the same. Hence, the LED produces more accurate results.

[0042] From the LED light source, light passes through the oil sample placed in a glass cuvette 212. The glass cuvette 212 is a cuboidal vessel made of quartz. The oil sample could be filled into it and could be placed in the optical path between light source and detector 110 by means of a cuvette slot 210. The system 100 may be optically shielded to prevent biases due to external radiation.

[0043] The controller 108 of the smartphone may control the wavelength of the light produced by the LED light source 208 such that light of a first wavelength and light a second wavelength (630nm and 450 nm, respectively) pass through the oil sample, within a pre-determined interval of time (e.g., 10 seconds), with each turn of the screw arrangement 214 such that entire oil sample is scanned. After passing through the sample the output radiation enters into the smartphone 102 through the detector 110. According to an exemplary embodiment, the detector 110 may be the camera of the smartphone 102. The detector 110 is configured to detect an output radiation produced by the light of the first wavelength and the light of the second wavelength after passing through the oil sample, over the time period, for each position of the glass cuvette 212.

[0044] According to an embodiment, the detector 110 may comprise a lens which is configured to converge the radiation detected by the detector 110. The lens is to be set on macro lens mode to converge the radiation. The detector 108 may further comprise an optical filter configured to disperse the radiation into RGB component. The optical filter is a Bayer filter. The detector 110 may further comprise a plurality of CMOS sensors each corresponding to a RGB wavelength configured to detect intensity of light detected by the detector 110.

[0045] Further, the processing unit 112 of the smartphone 102 may generate an image of each of the detected radiation pattern and process the captured images to evaluate the oil sample, as shown in fig 4a and 4b. Fig. 4a shows the radiation pattern for an oil sample and fig. 4b shows a radiation pattern for clear oil (blank sample). The images may be processed by exploring the data set further for more insights. The processing unit 112 may process the captured images to determine optical parameters such as optical transmittance, scattering index and optical absorbance of the oil sample. The optical transmittance is calculated by

$$T = I/I_0$$

wherein T represents intensity in a transmittance region of the radiation pattern.

[0046] The scattering index is calculated as integral sum of light intensity in a scattering region of the radiation pattern. The optical absorbance is calculated by

$$A = \ln(I/I_0)$$

wherein I represents the intensity in the sample oil and I_0 is the intensity of a blank sample.

[0047] The system 100 automatically records three optical parameters of oil sample till the entire sample is scanned vertically. In order to scan the entire sample vertically, the controller 108 of the smartphones allow the screw arrangement 214 to change vertical position of the glass cuvette 212, within the cuvette slot 210.

[0048] Further, the processing unit 112 may receive the values of degree of dilution of said oil sample in isooctane via an input interface of the smartphone or may fetch the same from the database 106. Based on the degree of dilution of said oil sample in isooctane, the processing unit 112 may fetch the calibration data from the database 106. Thereafter, the processing unit 112 may evaluate the determined optical transmittance, scattering index and optical absorbance, based on degree of dilution of said oil sample in isooctane and calibration data, to determine at least colour ratio of the oil sample, concentration of oil sludge floc, density profile of the oil sample, and turbidity of the oil sample.

[0049] In this manner, the system 100 may evaluate the oil sample using smartphone-based sensing in cost-effective and an efficient manner. Also, the data processing and sharing is easier. Further, such In-situ monitoring helps with the timely insights for the preventive maintenance of transformer, thus enhancing transformer's up-time. Also, there is no need of an operator skilled in testing due to the simplicity of the process.

[0050] Fig. 5 discloses a method 500 to evaluate the oil samples. At step 502, the method 500 comprises placing a glass cuvette 212 configured to hold an oil sample into a cuvette slot 210 present at centre of a housing 202 having a horizontal tubular passage extending from distal end 204 to proximal end 206 of the housing 202. The horizontal tubular passage is configured to allow passage of light from distal end 204 to the proximal end 206. According to an embodiment, said glass cuvette 212 is a cuboidal vessel made of quartz, to hold the oil sample and is placed in optical path between the LED light source 208 and the detector 110.

[0051] At step 504, the method 500 recites adjusting a position of the glass cuvette 212 in the cuvette slot 210 using a screw arrangement 214 attached at bottom of the cuvette slot. The screw arrangement 214 is configured to allow the glass cuvette 212 to move vertically into the cuvette slot 210 for vertical scanning of the oil sample.

[0052] At step 506, the method 500 recites controlling wavelength of light produced by a LED light source 208 such that light of a first wavelength and light a second wavelength pass through the oil sample, within a pre-determined interval of time, with each turn of the screw arrangement 214 such that entire oil sample is scanned.

[0053] At step 508, the method 500 recites detecting an output radiation, at a detector 110, produced by the light of the first wavelength and the light of the second wavelength after passing through the oil sample, over the time period, for each position of the glass cuvette 212. According to an embodiment, detecting the output radiation comprises converging the radiation detected by the detector 110 using a lens having macro mode. Detecting the radiation further comprises dispersing the radiation into RGB component using an optical filter, and detecting intensity of light detected by the detector 110 using a plurality of CMOS sensors each corresponding to a RGB wavelength of detected light.

[0054] The method 500 at step 510 describes generating an image of each of the detected radiation pattern. At step 512 method recites processing the captured images to evaluate the oil sample. Said processing the captured images comprises determining optical transmittance, scattering index and optical absorbance of the oil sample. The optical transmittance is calculated by

$$T = I/I_0$$

wherein T represents intensity in a transmittance region of the radiation pattern.

[0055] The scattering index is calculated as integral sum of light intensity in a scattering region of the radiation pattern. The optical absorbance is calculated by

$$A = \ln(I/I_0)$$

I represents the intensity in the sample oil and I_0 is the intensity of a blank sample.

[0056] The method 500 further comprises evaluating the determined optical transmittance, scattering index and optical absorbance, based on degree of dilution of said oil sample in isooctane and calibration data, to determine at least colour ratio of the oil sample, concentration of oil sludge floc, density profile of the oil sample, and turbidity of the oil sample. The processing unit 112 may receive the values of degree of dilution of said oil sample in isooctane via an input interface of the

smartphone or may fetch the same from a database. based on the degree of dilution of said oil sample in isooctane, the processing unit 112 may fetch the calibration data from the database.

[0057] In this manner, the oil sample may be evaluated using smartphone-based sensing in cost-effective and an efficient manner. Also, the data processing and sharing is easier. Further, such In-situ monitoring helps with the timely insights for the preventive maintenance of transformer, thus enhancing transformer's up-time. Also, there is no need of an operator skilled in testing due to the simplicity of the process.

[0058] The illustrated steps are set out to explain the exemplary embodiments shown, and it should be anticipated that ongoing technological development will change the manner in which particular functions are performed. These examples are presented herein for purposes of illustration, and not limitation. Further, the boundaries of the functional building blocks have been arbitrarily defined herein for the convenience of the description. Alternative boundaries can be defined so long as the specified functions and relationships thereof are appropriately performed.

[0059] Alternatives (including equivalents, extensions, variations, deviations, etc., of those described herein) will be apparent to persons skilled in the relevant art(s) based on the teachings contained herein. Such alternatives fall within the scope and spirit of the disclosed embodiments.

[0060] Furthermore, one or more computer-readable storage media may be utilized in implementing embodiments consistent with the present disclosure. A computer-readable storage medium refers to any type of physical memory on which information or data readable by a processor may be stored. Thus, a computer-readable storage medium may store instructions for execution by one or more processors, including instructions for causing the processor(s) to perform steps or stages consistent with the embodiments described herein. The term "computer-readable medium" should be understood to include tangible items and exclude carrier waves and transient signals, i.e., are non-transitory. Examples include random access memory (RAM), read-only memory (ROM), volatile memory, non-volatile memory, hard drives, CD ROMs, DVDs, flash drives, disks, and any other known physical storage media.

[0061] Suitable processors/controllers include, by way of example, a general purpose processor, a special purpose processor, a conventional processor, a digital signal processor (DSP), a plurality of microprocessors, one or more microprocessors in association with a DSP core, a controller, a microcontroller, Application Specific Integrated Circuits (ASICs), Field Programmable Gate Arrays (FPGAs) circuits, any other type of integrated circuit (IC), and/or a state machine.

WE CLAIM:

1. A system to evaluate oil samples, said system comprising:

an apparatus comprising:

a housing having a horizontal tubular passage extending from a distal end to a proximal end of the housing, wherein the horizontal tubular passage is configured to allow passage of light from the distal end to the proximal end;

a LED light source fixed at the distal end of the housing, wherein the LED light source is configured to produce light of plurality of wavelengths;

a cuvette slot at centre of the housing, configured to hold a glass cuvette, wherein the glass cuvette is configured to hold oil sample to be evaluated;

a screw arrangement attached at bottom of the cuvette slot to allow the glass cuvette to move vertically into the cuvette slot for vertical scanning of the oil sample; and

a smart phone operatively connected to said apparatus such that the proximal end of the housing of the apparatus is attached to camera of the smart phone, said smart phone comprising:

a controller configured to:

allow the screw arrangement to change vertical position of the glass cuvette, within the cuvette slot; and

control the wavelength of the light produced by the LED light source such that light of a first wavelength and light a second wavelength pass through the oil sample, within a pre-determined interval of time, with each turn of the screw arrangement such that entire oil sample is scanned;

a detector configured to detect an output radiation produced by the light of the first wavelength and the light of the second wavelength after passing through the oil sample, over the time period, for each position of the glass cuvette; and

a processing unit configured to generate an image of each of the detected radiation pattern; and

process the captured images to evaluate the oil sample.

2. The system as claimed in claim 1, wherein said glass cuvette is a cuboidal vessel made of quartz, to hold the oil sample and is placed in optical path between the LED light source and the detector.

3. The system as claimed in claim 1, wherein said detector comprises:
 - a lens configured to converge the radiation detected by the detector;
 - an optical filter configured to disperse the radiation into RGB component; and
 - a plurality of CMOS sensors each corresponding to a RGB wavelength configured to detect intensity of light detected by the detector.

4. The system as claimed in claim 1, wherein the processing unit is configured to process the captured images to determine optical transmittance, scattering index and optical absorbance of the oil sample,
 - wherein the optical transmittance is calculated by $T = I/I_0$, and wherein T represents intensity in a transmittance region of the radiation pattern,
 - wherein the scattering index is calculated as integral sum of light intensity in a scattering region of the radiation pattern, and
 - wherein the optical absorbance is calculated by $A = \ln(I/I_0)$, wherein I represents the intensity in the sample oil and I_0 is the intensity of a blank sample.

5. The system as claimed in claim 1, wherein the processing unit is configured to evaluate the determined optical transmittance, scattering index and optical absorbance, based on degree of dilution of said oil sample in isooctane and calibration data, to determine at least colour ratio of the oil sample, concentration of oil sludge floc, density profile of the oil sample, and turbidity of the oil sample.

6. A method for evaluating oil samples, said method comprising:
 - placing a glass cuvette configured to hold an oil sample into a cuvette slot present at centre of a housing having a horizontal tubular passage extending from a distal end to a proximal end of the housing, wherein the horizontal tubular passage is configured to allow passage of light from the distal end to the proximal end;
 - adjusting a position of the glass cuvette in the cuvette slot using a screw arrangement attached at bottom of the cuvette slot, wherein the screw arrangement is configured to allow the glass cuvette to move vertically into the cuvette slot for vertical scanning of the oil sample;

controlling wavelength of light produced by a LED light source such that light of a first wavelength and light a second wavelength pass through the oil sample, within a pre-determined interval of time, with each turn of the screw arrangement such that entire oil sample is scanned;

detecting an output radiation, at a detector, produced by the light of the first wavelength and the light of the second wavelength after passing through the oil sample, over the time period, for each position of the glass cuvette;

generating an image of each of the detected radiation pattern; and

processing the captured images to evaluate the oil sample.

7. The method as claimed in claim 6, wherein said glass cuvette is a cuboidal vessel made of quartz, to hold the oil sample and is placed in optical path between the LED light source and the detector.

8. The method as claimed in claim 6, wherein detecting the output radiation comprises:

converging the radiation detected by the detector,

dispersing the radiation into RGB component, and

detecting intensity of light detected by the detector using a plurality of CMOS sensors each corresponding to a RGB wavelength of detected light.

9. The method as claimed in claim 6, wherein processing the captured images comprises determining optical transmittance, scattering index and optical absorbance of the oil sample,

wherein the optical transmittance is calculated by $T = I/I_0$, and wherein T represents intensity in a transmittance region of the radiation pattern,

wherein the scattering index is calculated as integral sum of light intensity in a scattering region of the radiation pattern, and

wherein the optical absorbance is calculated by $A = \ln(I/I_0)$, wherein I represents the intensity in the sample oil and I_0 is the intensity of a blank sample.

10. The method as claimed in claim 9, further comprising:

evaluating the determined optical transmittance, scattering index and optical absorbance, based on degree of dilution of said oil sample in isooctane and calibration data, to determine at

least colour ratio of the oil sample, concentration of oil sludge floc, density profile of the oil sample, and turbidity of the oil sample.

Dated this 22nd day of August 2022

-- Digitally Signed--

Bhanu Prasad

(INPA No: 3253)

Manager, IPR Dept.,

L&T Technology Services Limited,

DLF 3rd Block, 2nd Floor,

Manapakkam, Chennai - 600089.

ABSTRACT

SYSTEM AND METHOD FOR EVALUATION OF OIL

The present invention relates a system and method to evaluate oil samples. The method comprises placing a glass cuvette configured to hold oil sample into a cuvette slot. The method further comprises adjusting a position of the glass cuvette in the cuvette slot using a screw arrangement. The screw arrangement is configured to allow the glass cuvette to move vertically into the cuvette slot. The method comprise controlling wavelength of light produced by a LED light source such that light of a first and a second wavelength pass through the oil sample, within a pre-determined interval of time, with each turn of the screw arrangement. Thereafter, radiation, produced by the light after passing through the oil sample, is detected over the time period, for each position of the glass cuvette. Thereafter, an image of each of the detected radiation pattern is generated and processed to evaluate the oil sample.

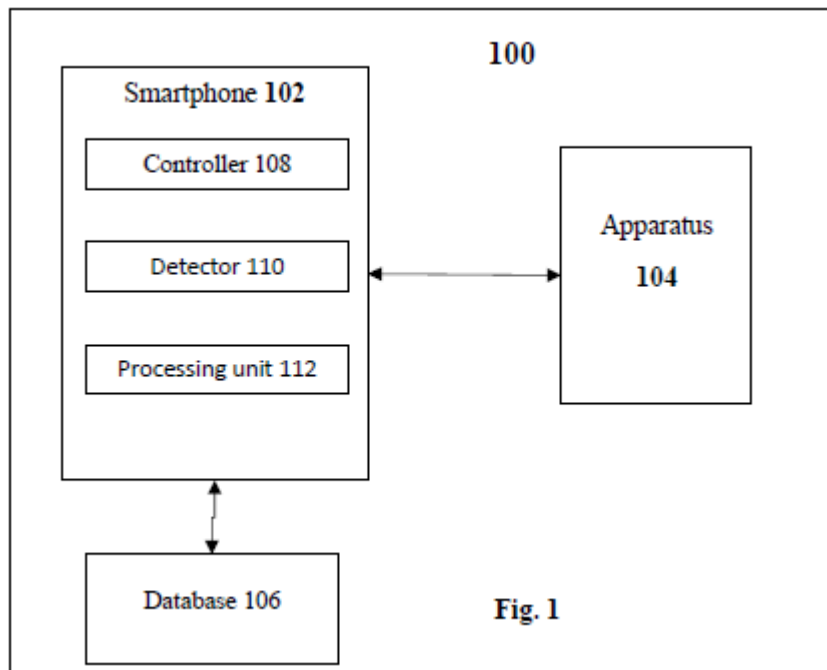

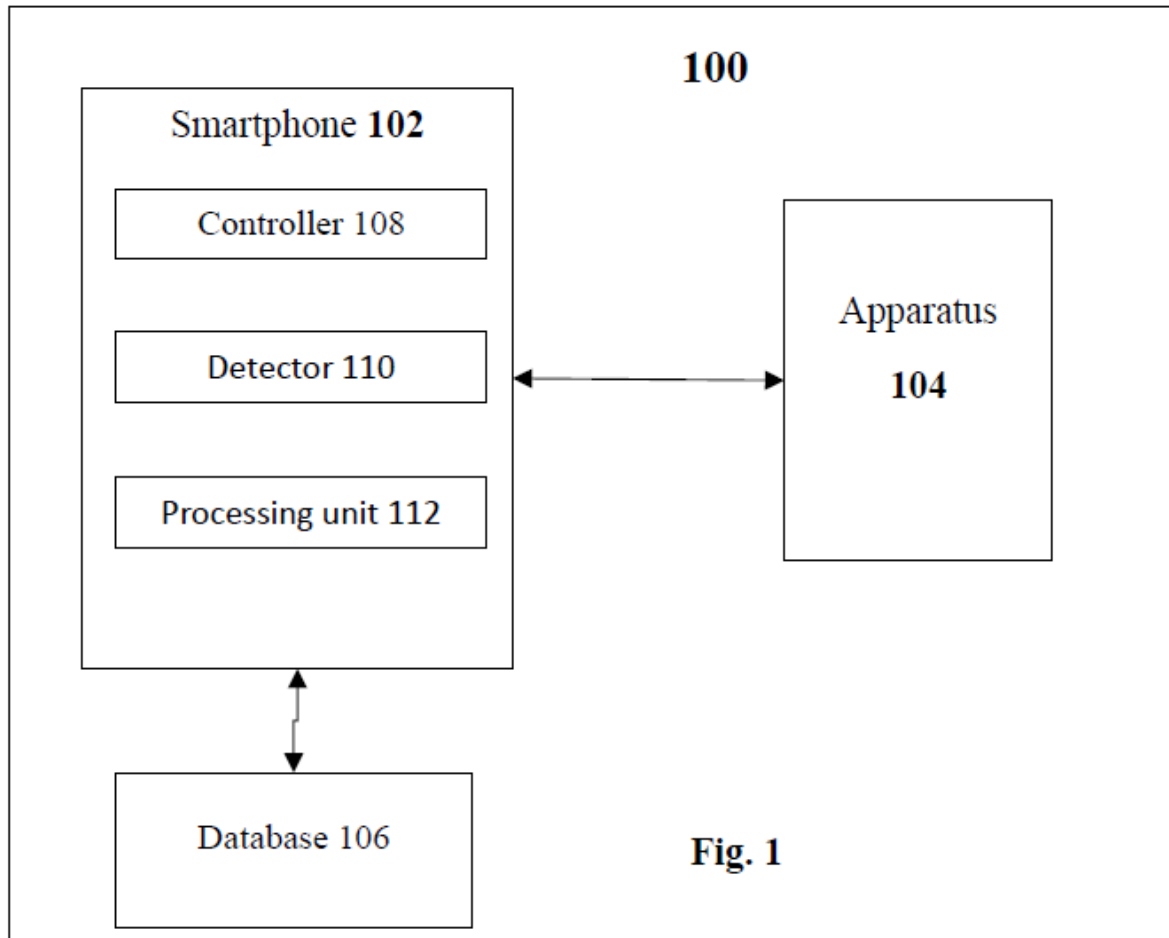

Fig. 1

Mohammed Faisal (INPA No: 1941)
Head, IPR Dept.,
L&T Technology Services Limited,
DLF 3rd Block, 2nd Floor,
Manapakkam, Chennai - 600089.

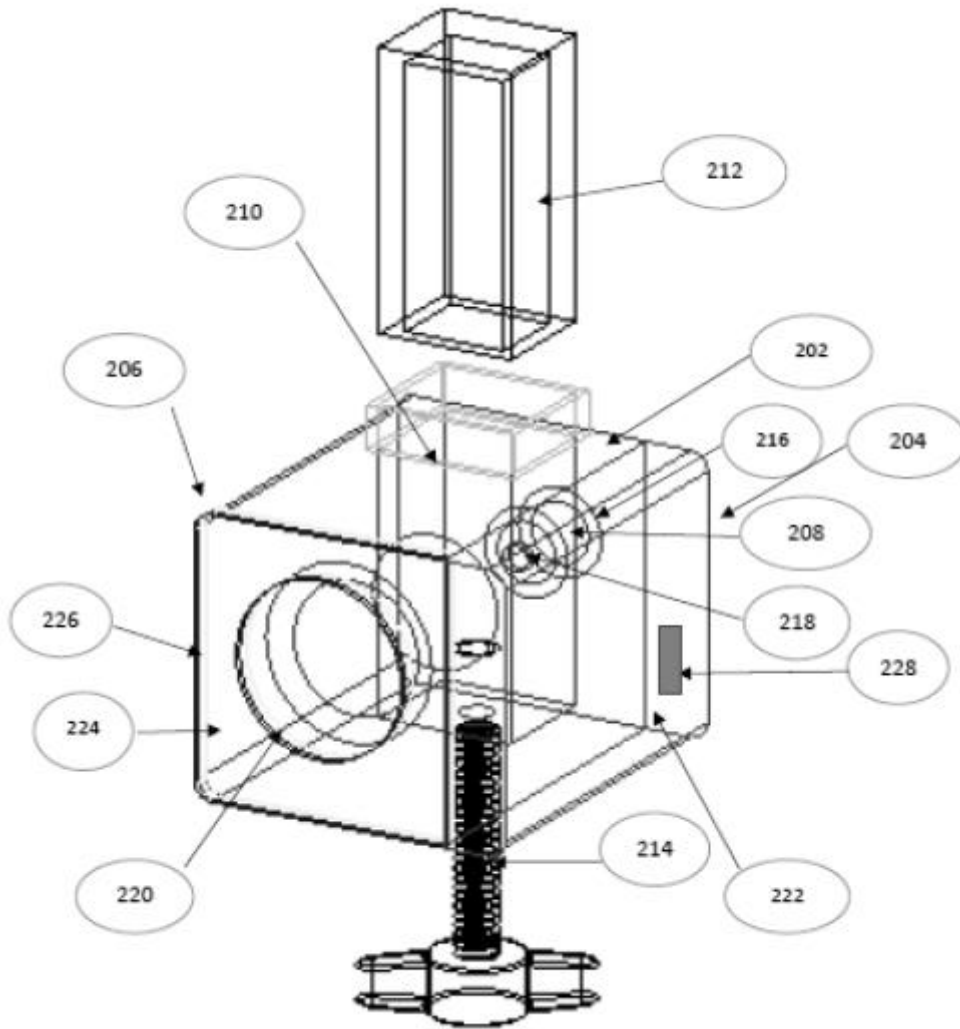

Fig. 2

Mohammed Faisal (INPA No: 1941)
Head, IPR Dept.,
L&T Technology Services Limited,
DLF 3rd Block, 2nd Floor,
Manapakkam, Chennai - 600089.

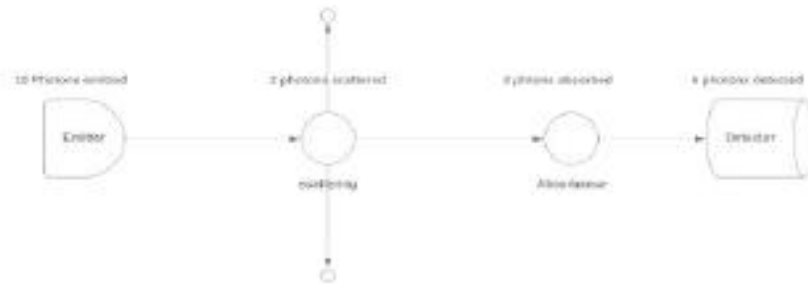
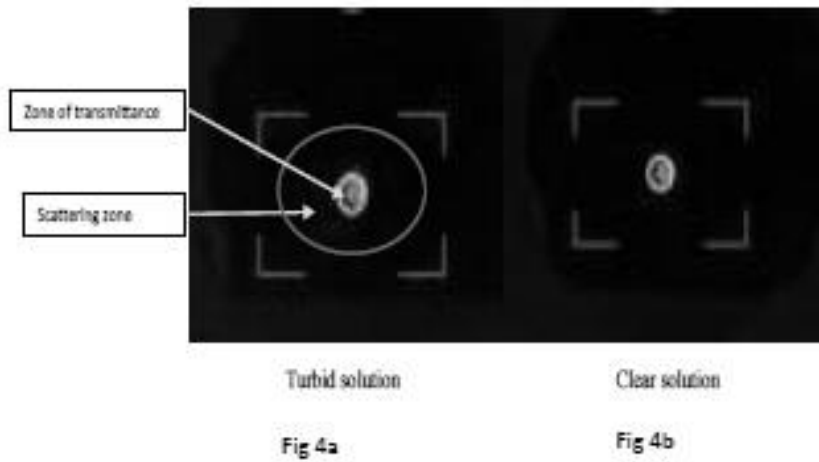
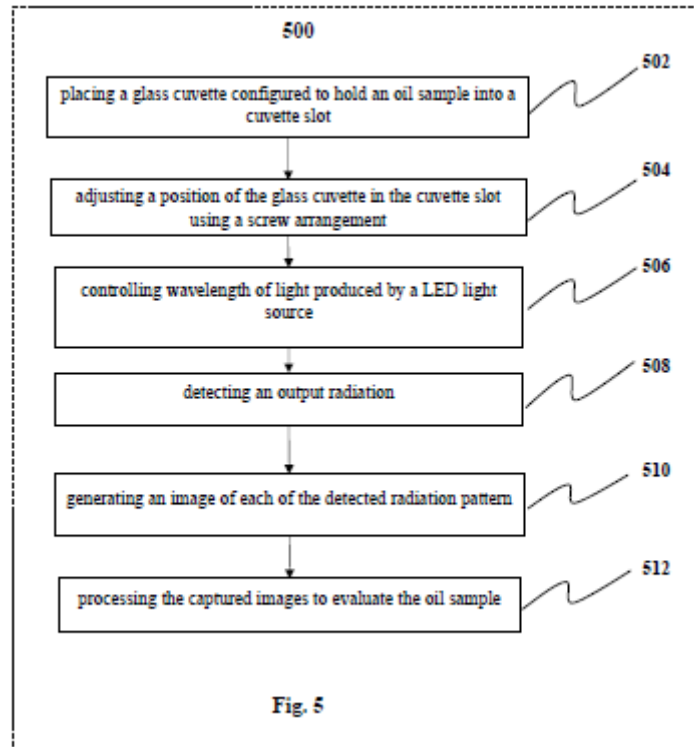

Fig. 3



Mohammed Faisal (INPA No: 1941)
Head, IPR Dept.,
L&T Technology Services Limited,
DLF 3rd Block, 2nd Floor,
Manapakkam, Chennai - 600089.



Mohammed Faisal (INPA No: 1941)
Head, IPR Dept.,
L&T Technology Services Limited,
DLF 3rd Block, 2nd Floor,
Manapakkam, Chennai - 600089.