

(12) Indian Patent Application

(21) Application Number: 202141056010

(22) Filing Date: 02/12/2021 (43) Publication Date: 09/06/2023

(71) Applicant(s): L&T TECHNOLOGY SERVICES LIMITED

(72) Inventor(s): Bethapudi, Harold Theophilus McNally

(51) International Classifications: G01R 31/11 G01S 13/88 G01R 31/08 B66B 19/02 G01S 13/10

(54) Title: METHOD AND SYSTEM FOR ASSESSING AN ELEVATOR HOISTWAY

(57) Abstract: A method and system for assessing an elevator hoistway is disclosed. The method may include injecting a high-frequency electromagnetic pulse into an elevator hoistway rope from one of a first end and a second end of the elevator hoistway rope. The method may further include receiving a reflected signal corresponding to the injected high-frequency electromagnetic pulse, upon reflection of the high-frequency electromagnetic pulse along the elevator hoistway rope. The method may further include determining a velocity of propagation (VoP) based on an analysis of the reflected signal and the injected high-frequency electromagnetic pulse. The method may further include determining a location of a fault along the elevator hoistway rope, based on the VoP.

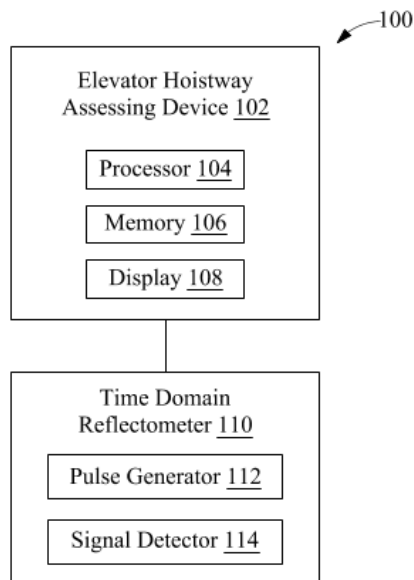

FIG. 1

FORM 2

THE PATENTS ACT 1970
(39 OF 1970)
&
The Patent Rules, 2003
Complete Specification
(See Section 10 and Rule 13)

1. TITLE OF THE INVENTION

METHOD AND SYSTEM FOR ASSESSING AN ELEVATOR HOISTWAY

2. APPLICANT(S)

(a) NAME : **L&T TECHNOLOGY SERVICES LIMITED**
(b) NATIONALITY : **INDIAN**
(c) ADDRESS : **DLF IT SEZ Park, 2nd Floor – Block 3,
1/124, Mount Poonamallee Road, Ramapuram,
Chennai – 600 089, INDIA.**

3. PREAMBLE TO THE DESCRIPTION

COMPLETE

The following specification particularly describes the invention and the manner in which it is to be performed.

DESCRIPTION

Technical Field

[001] This disclosure relates generally to elevator hoistway, and more particularly to a method and a system for assessing an elevator hoistway for detecting faults in the elevator hoistway, and determining location and occupancy of a cabin of the elevator system.

BACKGROUND OF THE INVENTION

[002] Elevator wire ropes, which are usually steel ropes, hold heavy fluctuating loads in a corrosive environment. Such working conditions may cause metal fatigue which together with abrasion around pulleys may lead to progressive loss of the cross-section of the rope. The deterioration of the ropes during its lifetime leads to a reduction of the rope safety factor and therefore must be monitored so that any unexpected damage or corrosion can be detected before it causes a fatal accident.

[003] A rope rejection criterion can be divided into qualitative and quantitative ones. The qualitative criteria can be various types of deformations and damages as a result of a high temperature or a flash influence, for example, a strand or a metallic core break. The quantitative criteria may include diameter change, surface or inner abrasive wear, and corrosion of wires, which may lead to loss of metallic cross-section area.

[004] There is therefore a need in the present state of the art for a method for efficiently assessing the elevator ropes.

SUMMARY OF THE INVENTION

[005] In one embodiment, a method of assessing an elevator hoistway is disclosed. The method may include injecting a high-frequency electromagnetic pulse into an elevator hoistway rope from one of a first end and a second end of the elevator hoistway rope. The first end of the elevator hoistway rope may be connected to a cabin configured to receive one or more occupants and a second other end of the elevator hoistway rope is connected to a counterweight. The elevator hoistway rope may be configured to traverse over a pulley between the first end and the second end. The method may further include receiving a reflected signal corresponding to the injected high-frequency electromagnetic pulse, upon reflection of the high-frequency electromagnetic pulse along the elevator hoistway rope.

The method may further include determining a velocity of propagation (VoP) based on an analysis of the reflected signal and the injected high-frequency electromagnetic pulse. The method may further include determining a location of a fault along the elevator hoistway rope, based on the VoP.

[006] In one embodiment, a system for assessing an elevator hoistway is disclosed. The system may include a time-domain reflectometer, a processor, and a memory which stores a plurality of instructions. The plurality of instructions, upon execution by the processor, may cause the processor to assess an elevator hoistway. The time-domain reflectometer may be configured to inject a high-frequency electromagnetic pulse into an elevator hoistway rope from one of a first end and a second end of the elevator hoistway rope. The plurality of instructions may cause the processor to receive a reflected signal corresponding to the injected high-frequency electromagnetic pulse, upon reflection of the high-frequency electromagnetic pulse along the elevator hoistway rope, determine a velocity of propagation (VoP) based on an analysis of the reflected signal and the injected high-frequency electromagnetic pulse. The plurality of instructions may further cause the processor to determine a location of a fault along the elevator hoistway rope, based on the VoP. The plurality of instructions may further cause the processor to determine an elongation in the length of the elevator hoistway rope at the pulley based on the calculated time difference, estimate a position of a cabin based on the elongation, and estimate a number of occupants inside the cabin based on the elongation.

BRIEF DESCRIPTION OF THE DRAWINGS

[007] The accompanying drawings, which are incorporated in and constitute a part of this disclosure, illustrate exemplary embodiments and, together with the description, serve to explain the disclosed principles.

[008] **FIG. 1** illustrates a block diagram of a system for assessing an elevator hoistway, in accordance with an embodiment of the present disclosure;

[009] **FIG. 2** illustrates a functional block diagram of an elevator hoistway assessing device, in accordance with an embodiment of the present disclosure;

[010] **FIG. 3** illustrates a schematic view of an elevator system, in accordance with an embodiment of the present disclosure;

[011] **FIG. 4** illustrates a schematic view of a measurement setup on an elevator system, in accordance with an embodiment of the present disclosure;

[012] **FIG. 5** illustrates a graphical representation of a Time Domain Reflectometer (TDR) waveform, in accordance with an embodiment of the present disclosure;

[013] **FIG. 6** illustrates a schematic representation of a TDR waveform corresponding to an elevator rope revealing discontinuities on the elevator rope, in accordance with an embodiment of the present disclosure;

[014] **FIG. 7** illustrates a cross-sectional view of an elevator rope, in accordance with an embodiment of the present disclosure

[015] **FIG. 8** illustrates a Table showing commonly used rope diameters in the elevator rope sector in various different countries, in accordance with an embodiment of the present disclosure;

[016] **FIG. 9** illustrates a tabular representation of some approximate values of constructional stretch for different rope classes based on previous manufacturing data, in accordance with an embodiment of the present disclosure?

[017] **FIGs. 10A-10C** illustrate graphical representations of impedance response of the composite specimens under progressively increasing cyclic loading for three different specimens, in accordance with an embodiment of the present disclosure;

[018] **FIG. 11** illustrates a block diagram of a TDR circuit, in accordance with an embodiment of the present disclosure; and

[019] **FIG. 12** is a flowchart of a method of assessing an elevator hoistway, in accordance with an embodiment of the present disclosure.

DETAILED DESCRIPTION OF THE DRAWINGS

[020] Exemplary embodiments are described with reference to the accompanying drawings. Wherever convenient, the same reference numbers are used throughout the drawings to refer to the same or like parts. While examples and features of disclosed principles are described herein, modifications, adaptations, and other implementations are possible without departing from the spirit and scope of the disclosed embodiments. It is intended that the following detailed description be considered as exemplary only, with the true scope and spirit being indicated by the following claims. Additional illustrative embodiments are listed.

[021] In an embodiment, a method for assessing an elevator hoistway is disclosed. A velocity of propagation (VoP) may be determined by calculating a time difference between the injected high-frequency electromagnetic pulse and the reflected signal based on the analysis of the reflected signal and the injected high-frequency electromagnetic pulse. A location of a fault along the elevator hoistway rope may be determined based on the VoP and mapping a shape of the reflected signal with a plurality of predefined shapes. In an embodiment, a method for assessing an elevator hoistway is disclosed. The method may include determining an elongation in the length of the elevator hoistway rope at the pulley based on the calculated time difference and estimating a position of a cabin based on the elongation. The method may include estimating a number of occupants inside the cabin based on the elongation. The elongation may be proportional to a load of the cabin. The load of the cabin may be further proportional to the number of occupants inside the cabin.

[022] Referring now to FIG. 1, a block diagram of a system 100 for assessing an elevator hoistway is illustrated, in accordance with an embodiment of the present disclosure. As shown in FIG. 1, the system 100 may include an elevator hoistway assessing device 102 and a time-domain reflectometer 110. The elevator hoistway assessing device 102 may be coupled to the time-domain reflectometer 110. Further, the time domain reflectometer 110 may include a pulse generator 112 and a signal detector 114.

[023] The system 100 may be configured to inject a high-frequency electromagnetic pulse into an elevator hoistway rope from one of the first end and the second end of the elevator hoistway rope. The system 100 may be further configured to receive a reflected signal corresponding to the injected high-frequency electromagnetic pulse, upon reflection of the high-frequency electromagnetic pulse

along the elevator hoistway rope. Further, the system 100 may be configured to determine a velocity of propagation (VoP) based on an analysis of the reflected signal and the injected high-frequency electromagnetic pulse and also determine a location of a fault along the elevator hoistway rope, based on the VoP.

[024] In order to perform the above-discussed functionalities, the elevator hoistway assessing device 102 may include a processor 104, a memory 106, and a display 108. The memory 106 may store instructions that, when executed by the processor 104, cause the processor 104 to determine the location of a fault along the elevator hoistway rope. The memory 106 may be a non-volatile memory or a volatile memory. Examples of non-volatile memory may include, but are not limited to a flash memory, a Read-Only Memory (ROM), a Programmable ROM (PROM), Erasable PROM (EPROM), and Electrically EPROM (EEPROM) memory. Examples of volatile memory may include but are not limited to Dynamic Random-Access Memory (DRAM), and Static Random-Access memory (SRAM). The memory 106 may also store various data that may be captured, processed, and/or required by the system. The elevator hoistway device 102 may further include a display 108 which may be configured to display various data, for example data related to a location of the fault.

[025] The time-domain reflectometer 110 may include the pulse generator 112 for generating a high-frequency electromagnetic pulse into an elevator hoistway rope from one of the first end and the second end of the elevator hoistway rope through a pair of conductors also known as transmission lines. The first end of the elevator hoistway rope may be connected to a cabin configured to receive one or more occupants and the second end of the elevator hoistway rope may be connected to a counterweight. The elevator hoistway rope may be configured to traverse over a pulley between the first end and the second end. Further, the time domain reflectometer may include a signal detector 114 for detecting the reflected signal corresponding to the injected high-frequency electromagnetic pulse, upon reflection of the high-frequency electromagnetic pulse along the elevator hoistway rope. The reflected signal may be created in response to a change in the characteristic impedance of the elevator hoistway rope due to a discontinuity in the elevator hoistway rope. Every discontinuity along the transmission line (hoistway steel rope) results in reflected waveforms. The spatial location of the discontinuities can be estimated by using the time domain location of the reflected waveforms.

[026] Referring now to FIG. 2, a functional block diagram 200 of the elevator hoistway assessing device 102 is illustrated, in accordance with an embodiment of the present disclosure. The elevator

hoistway assessing device 102 may include a reflected signal receiving module 202, a velocity of propagation determining module 204, and a fault location determining module 206.

[027] The reflected signal receiving module 202 may receive the reflected signal corresponding to the injected high-frequency electromagnetic pulse, upon reflection of the high-frequency electromagnetic pulse along the elevator hoistway rope. The reflected signal may be created in response to a change in the characteristic impedance of the elevator hoistway rope due to a discontinuity in the elevator hoistway rope. The velocity of propagation determining module 204 may determine the velocity of propagation (VoP) based on an analysis of the reflected signal and the injected high-frequency electromagnetic pulse. The fault location determining module 206 may determine the location of a fault along the elevator hoistway rope, based on the VoP.

[028] Referring now to FIG. 3, a schematic view of an elevator system 300 is illustrated, in accordance with an embodiment of the present disclosure. As shown in FIG 3 an elevator system 300 may include an elevator car 302, a counterweight 304, a tension member (rope) 306, and a pulley 308. The elevator car 302 and counterweight 304 may be connected to each other by the tension member (rope) 306 around the pulley 308. The tension member 306 may include or be configured as, for example, steel ropes, and/or steel cables. The counterweight 304 may be configured to balance a load of the elevator car 302 and may be configured to facilitate movement of the elevator car 302 concurrently and in an opposite direction with respect to the counterweight 304. The pulley 308 receives the hoist rope 306, so that when the pulley 308 rotates, the hoist rope 306 also moves.

[029] Referring now to FIG. 4, a schematic view of a measurement setup 400 on an elevator system is illustrated, in accordance with an embodiment of the present disclosure. As shown in FIG, 4, the measurement setup 400 on an elevator system may include a pulse generator 402 and a signal detector 404. The pulse generator 402 may be configured to generate high-frequency electromagnetic pulse through a pair of conductors (called transmission lines) and as the pulse travels down a steel rope 406, any changes in the characteristic impedance may cause some of the incident signals to reflect back to the source. The reflected signal may be created in response to a change in the characteristic impedance of the elevator hoistway steel rope 406 due to a discontinuity in the elevator hoistway rope 406. The reflected pulse can be positive or negative based on the characteristic impedance changes in the hoistway steel rope 406. Further, upon receiving the reflected signal, the reflected signal may

be detected by the signal detector 404 for any discontinuity and for determining spatial location of the discontinuity along the steel rope 406.

[030] Referring now to FIG. 5, a graphical representation of a Time Domain Reflectometer (TDR) waveform 500 is illustrated, in accordance with an embodiment of the present disclosure. The waveform 500 represents the effect of all the reflections created by the impedance discontinuities, as shown in FIG. 5. The waveform 500 can be evaluated to determine how much the impedance deviates from the nominal value ranging from negative to positive axis. It can be seen from the analysis of the different curves that due to attenuation (cable loss), the reflections caused by each of the equally spaced, yet identical taps are progressively smaller. A larger reflection (second cursor) beyond a smaller reflection may indicate an undetermined or faulty tap.

[031] Referring now to FIG. 6, a schematic representation 600 of a TDR waveform corresponding to an elevator rope revealing discontinuities on the elevator rope is illustrated, in accordance with an embodiment of the present disclosure. The waveform depicts the outcome of an ideal pulse traveling through a transmission medium. A TDR generates an accurately controlled pulse with a rapid rise time. As the data pulse travels along the same transmission path, the data pulse aberration will encounter multiple discontinuities in the transmission path, resulting in random, intermittent issues. As will be appreciated, the TDR impedance measurements are performed for improved signal integrity (after correcting the discontinuities).

[032] Referring now to FIG. 7, a cross-sectional view of an elevator rope 700 is illustrated, in accordance with an embodiment of the present disclosure. The elevator rope 700 may include multiple wires, wire strands, and a fiber core. The wires make up the individual strands in the rope. The wires can be made from a variety of metal materials, for example, steel, iron, stainless steel, and bronze, and can be coated or uncoated. The wires can be manufactured in a variety of grades that relate to the strength, resistance to wear, fatigue resistance, corrosion resistance, and curve of the wire rope. The strands of wire may be made up of two or more wires that have been twisted and arranged in a specific pattern. The individual strands are wrapped around the fiber core in a helical pattern. The strands made of larger diameter wires are more abrasion-resistant, whereas strands made of smaller diameter wires are more flexible. The fiber core may run through the center of the rope and support the strands and helps to maintain their relative position under loading and bending stresses. The fiber core can be made from several different materials for example, natural or synthetic fibers or steel. The most

commonly used rope diameters in the elevator sector in various countries are shown in FIG. 8. FIG. 8 illustrates a Table 800 showing commonly used rope diameters in the elevator rope sector in various different countries.

[033] As will be appreciated, when a wire rope is subjected to load, its constituents may attempt to pull down, resulting in an increase in wire rope length. This phenomenon is known as constructional stretch and it may be difficult to determine empirically because its extent depends on a variety of factors. Some approximate values of constructional stretch for different rope classes based on previous manufacturing data are shown in Table 900 in FIG. 9. By the way of an example, elastic stretch calculation is shown for a particular wire diameter.

[034] By way of an example, for,

car weight = 600 kg (standard low-rise elevators),

counterweight = 900 kg (Car Weight + 40-50% of elevator maximum capacity),

drive pulley diameter = 240 to 640 mm, and

wire rope diameter = ½ inch (12.7 mm)

The elastic Stretch = $[W * L] / [E * A]$

where,

W = Applied Load (N) = 8826 N (Approx. 900kg)

L = Rope Length (mm) = 40000 mm (for 10 storey building)

E = Modulus of Elasticity (N/mm²) = 55000 N/mm² (for 8 strand fibre core rope)

A = Metallic Area of Rope (mm²) = $(\pi * r^2) = (\pi * 40.3225) \approx 128 \text{ mm}^2$

Accordingly, for the above parameters,

elastic stretch (mm) = 50.15 mm;

constructional stretch (for 10 storey building) = $0.75 * 40000/100 = 300$ mm;

and

Total Rope Stretch = Constructional Stretch + Elastic Stretch = $300 + 50.15 = 350.15$ mm

[035] Referring now to FIGs. 10A-10C, graphical representations 1000A, 1000B, 1000C of impedance response of the composite specimens under progressively increasing cyclic loading of 5000 N for three different specimens are illustrated, in accordance with an embodiment of the present disclosure. An average value of TDR output voltages from 150.5 to 151.5 NS may be used to compute the average specimen impedance. A correlation between strain and impedance can be observed for the specimen, and a good specimen to specimen repeatability is observed.

[036] Referring now to FIG. 11, a block diagram of a TDR circuit 1100 is illustrated, in accordance with an embodiment of the present disclosure. A Time Domain Reflectometry (TDR) instrument measures the reflections that result from a signal traveling through a transmission environment, for example, a circuit board trace, a cable, a steel rope, a connector, and so on. The TDR instrument sends a pulse into the hoistway steel rope at one end and as the pulse travels down the steel rope, any changes in the characteristic impedance will cause some of the incident signal to be reflected to the source. The time difference between the incident and reflected pulses, based on the analysis of the reflected signal and the injected high-frequency electromagnetic pulse helps in determining the velocity of propagation (VoP), which may provide details of fault location. Based on the characteristic impedance variations in the hoistway steel rope, the reflected pulse can be positive or negative, and the pulse forms can be mapped with a plurality of predefined shapes. The problems related to these impedance changes can be traced back to the rope's most common flaws. With the present technique, defect areas may be promptly identified without the need for physical intervention, and results can be obtained in a matter of seconds.

[037] TDR measurements may be described in terms of a Reflection Coefficient, ρ (rho). The coefficient ρ is the ratio of the reflected pulse amplitude to the incident pulse amplitude and for a fixed termination ZL, ρ can also be expressed in terms of the transmission line characteristic impedance, ZO, and the load impedance ZL.

$$\rho = V_{\text{reflected}} / V_{\text{incident}} = (Z_L - Z_0) / (Z_L + Z_0)$$

[038] Referring now to FIG. 12, a method 1200 of assessing an elevator hoistway is depicted via flowchart, in accordance with an embodiment of the present disclosure. At step 1202, a reflected signal may be received by the time domain reflectometer corresponding to the injected high-frequency electromagnetic pulse, upon reflection of the high-frequency electromagnetic pulse along the elevator hoistway rope. The reflected signal may be created in response to a change in the characteristic impedance of the elevator hoistway rope due to a discontinuity in the elevator hoistway rope. At step 1204 a velocity of propagation (VoP) may be determined based on an analysis of the reflected signal and the injected high-frequency electromagnetic pulse. The VoP may be determined by calculating a time difference between the injected high-frequency electromagnetic pulse and the reflected signal based on the analysis of the reflected signal and the injected high-frequency electromagnetic pulse. On the basis of the calculated time difference, an elongation in the length of the elevator hoistway rope at the pulley may be determined and on the basis of the elongation, a position of a cabin may be estimated. At step 1206 a location of a fault along the elevator hoistway rope may be determined, based on the VoP.

[039] The disclosed method enables identification of fault location without any need for traversing along the cable. Further, the method reduces the need for conventional methods that are currently in use by being both quick and inexpensive. The method also aids in determining cabin position based on the elongation of the hoistway steel rope at the pulley. Because the elongation at the pulley experienced by the hoistway is proportional to the cabin load due to the number of people entering the cabin, cabin load can also be extracted using this technique. The method allows for rapid monitoring of the elevator hoistway steel ropes. The measurement equipment required is small and can be deployed on the car's top of an elevator.

[040] It is intended that the disclosure and examples be considered as exemplary only, with a true scope and spirit of disclosed embodiments being indicated by the following claims.

CLAIMS

We Claim:

1. A method comprising of assessing an elevator hoistway:

injecting a high frequency electromagnetic pulse into an elevator hoistway rope from one of a first end and a second end of the elevator hoistway rope,

wherein the first end of the elevator hoistway rope is connected to a cabin configured to receive one or more occupants, and

wherein the second other end of the elevator hoistway rope is connected to a counterweight, and

wherein the elevator hoistway rope is configured to traverse over a pulley between the first end and the second end;

receiving a reflected signal corresponding to the injected high frequency electromagnetic pulse, upon reflection of the high frequency electromagnetic pulse along the elevator hoistway rope, wherein the reflected signal is created in response to change in characteristic impedance of the elevator hoistway rope due to a discontinuity in the elevator hoistway rope;

determining a velocity of propagation (VoP) based on an analysis of the reflected signal and the injected high frequency electromagnetic pulse; and

determining a location of a fault along the elevator hoistway rope, based on the VoP.

2. The method as claimed in claim 1 further comprising:

calculating a time difference between the injected high frequency electromagnetic pulse and the reflected signal based on the analysis of the reflected signal and the injected high frequency electromagnetic pulse; and

determining the VoP based on the calculated time difference.

3. The method as claimed in claim 1 further comprising:

mapping a shape of the reflected signal with a plurality of predefined shapes; and

determining the location of the fault along the elevator hoistway rope, based on the VoP and the mapping.

4. The method as claimed in claim 2 further comprising:

determining an elongation in the length of the elevator hoistway rope at the pulley based on the calculated time difference; and

estimating a position of a cabin based on the elongation.

5. The method as claimed in claim 4 further comprising:

estimating a number of occupants inside the cabin based on the elongation,

wherein the elongation is proportional to a load of the cabin, and

wherein the load of the cabin is further proportional to the number of occupants inside the cabin.

6. A system for assessing an elevator hoistway:

a time domain reflectometer configured to inject a high frequency electromagnetic pulse into an elevator hoistway rope from one of a first end and a second end of the elevator hoistway rope,

wherein the first end of the elevator hoistway rope is connected to a cabin configured to receive one or more occupants, and

wherein the second other end of the elevator hoistway rope is connected to a counterweight, and

wherein the elevator hoistway rope is configured to traverse over a pulley between the first end and the second end;

a processor coupled to the time domain reflectometer; and

a memory coupled to the processor, wherein the memory stores a plurality of processor-executable instructions, wherein the plurality of processor-executable instructions, upon execution by the processor, cause the processor to:

receive a reflected signal corresponding to the injected high frequency electromagnetic pulse, upon reflection of the high frequency electromagnetic pulse along the elevator hoistway rope, wherein the reflected signal is created in response to change in characteristic impedance of the elevator hoistway rope due to a discontinuity in the elevator hoistway rope;

determine a velocity of propagation (VoP) based on an analysis of the reflected signal and the injected high frequency electromagnetic pulse; and

determine a location of a fault along the elevator hoistway rope, based on the VoP.

7. The system as claimed in claim 6, wherein the plurality of processor-executable instructions further cause the processor to:

calculate a time difference between the injected high frequency electromagnetic pulse and the reflected signal based on the analysis of the reflected signal and the injected high frequency electromagnetic pulse; and

determine the VoP based on the calculated time difference.

8. The system as claimed in claim 6, wherein the plurality of processor-executable instructions further cause the processor to:

map a shape of the reflected signal with a plurality of predefined shapes; and

determine the location of the fault along the elevator hoistway rope, based on the VoP and the mapping.

9. The system as claimed in claim 7, wherein the plurality of processor-executable instructions further cause the processor to:

determine an elongation in the length of the elevator hoistway rope at the pulley based on the calculated time difference; and

estimate a position of a cabin based on the elongation.

10. The system as claimed in claim 9, wherein the plurality of processor-executable instructions further cause the processor to:

estimate a number of occupants inside the cabin based on the elongation,

wherein the elongation is proportional to a load of the cabin, and

wherein the load of the cabin is further proportional to the number of occupants inside the cabin.

Dated this 02nd Day of December 2021

Robin Koshy Varghese (INPA No: 3705)
Head, IPR Dept.
L&T Technology Services Ltd.
DLF 3rd Block, 2nd Floor,
Manapakkam, Chennai - 600089.

METHOD AND SYSTEM FOR ASSESSING AN ELEVATOR HOISTWAY

ABSTRACT

A method and system for assessing an elevator hoistway is disclosed. The method may include injecting a high-frequency electromagnetic pulse into an elevator hoistway rope from one of a first end and a second end of the elevator hoistway rope. The method may further include receiving a reflected signal corresponding to the injected high-frequency electromagnetic pulse, upon reflection of the high-frequency electromagnetic pulse along the elevator hoistway rope. The method may further include determining a velocity of propagation (VoP) based on an analysis of the reflected signal and the injected high-frequency electromagnetic pulse. The method may further include determining a location of a fault along the elevator hoistway rope, based on the VoP.

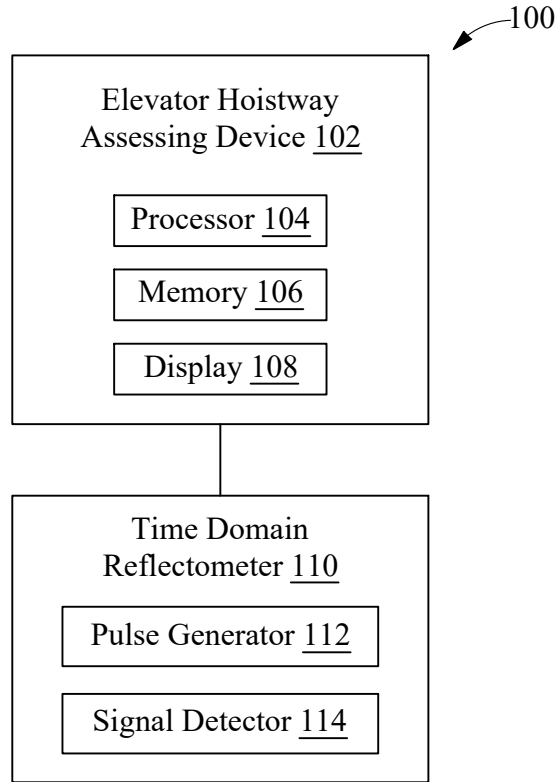

FIG. 1

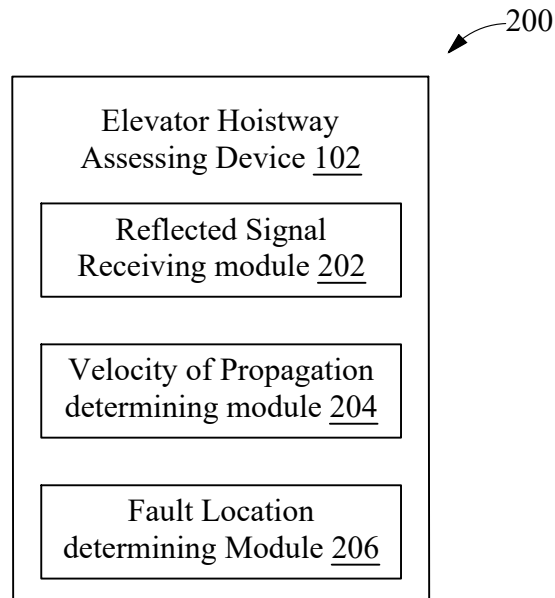

FIG. 2

Robin Koshy Varghese (INPA No: 3705)
Head, IPR Dept.,
L&T Technology Services Limited,
DLF 3rd Block, 2nd Floor,
Manapakkam, Chennai - 600089.

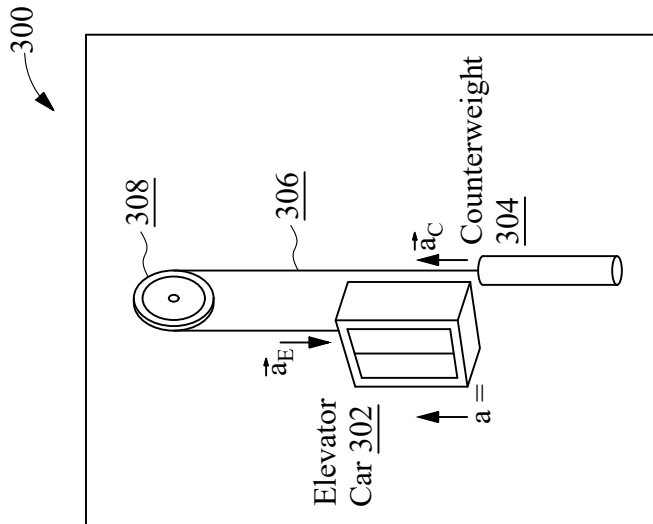

FIG. 3

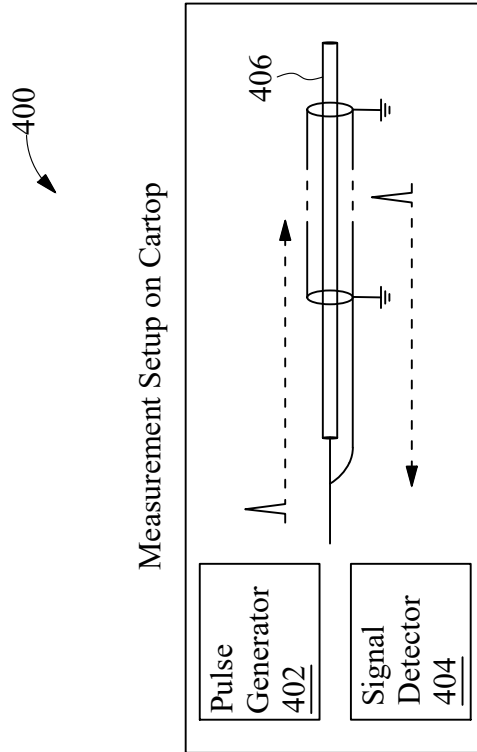

FIG. 4

Robin Koshy Varghese (INPA No: 3705)
Head, IPR Dept.,
L&T Technology Services Limited,
DLF 3rd Block, 2nd Floor,
Manapakkam, Chennai - 600089.

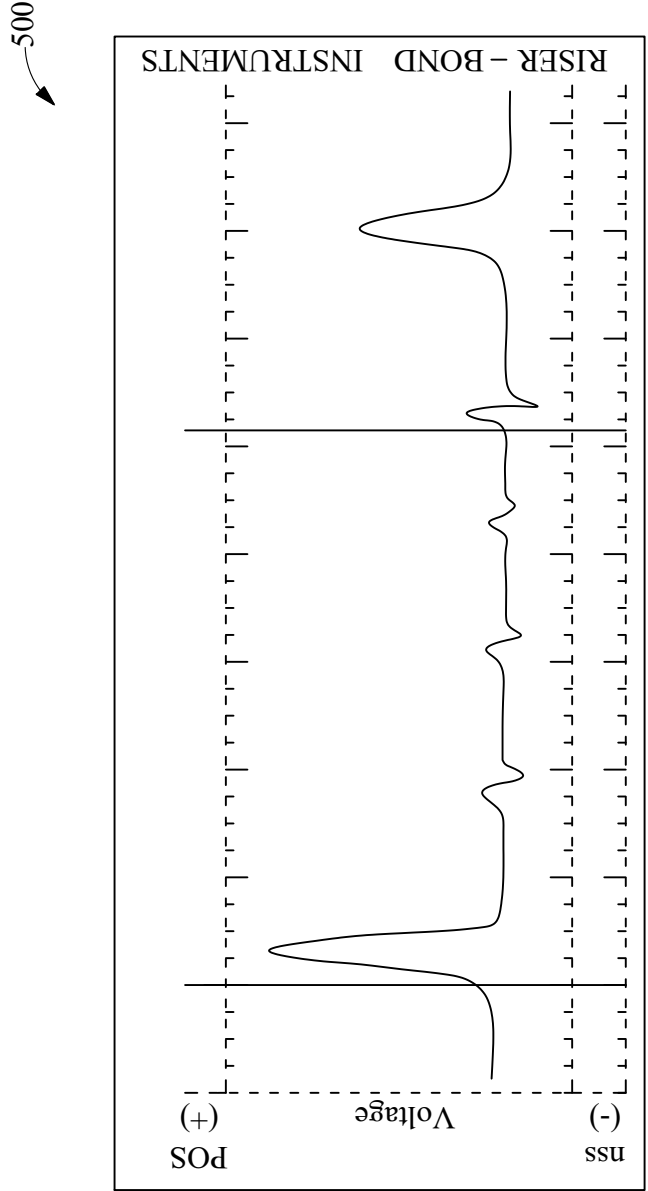

FIG. 5

Robin Koshy Varghese (INPA No: 3705)
Head, IPR Dept.,
L&T Technology Services Limited,
DLF 3rd Block, 2nd Floor,
Manapakkam, Chennai - 600089.

600

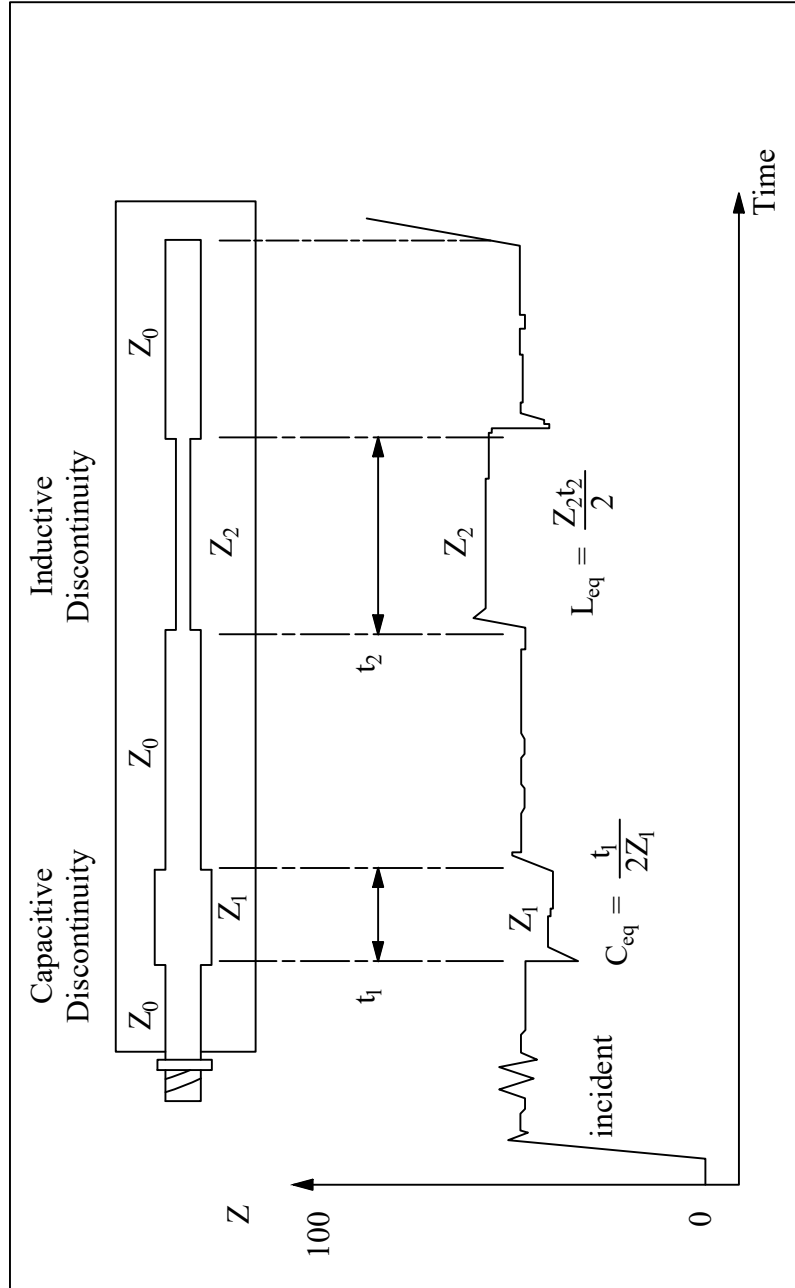
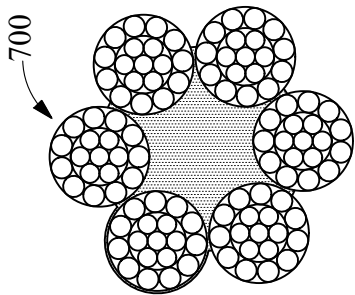

FIG. 6

Robin Koshy Varghese (INPA No: 3705)
Head, IPR Dept.,
L&T Technology Services Limited,
DLF 3rd Block, 2nd Floor,
Manapakkam, Chennai - 600089.

800

Rope diameter		Traction susp. rope		Europe Roped hydraulic susp. rope		Governor rope		USA Suspension rope		Governor rope		Japan Suspension rope	
mm	inch												
6		X ⁽¹⁾				X							
6.5		X ⁽¹⁾				X ⁽²⁾							
8		X ⁽²⁾		X		X						X	
9		X										X	
	3/8							(X)		X			
10		X ⁽³⁾		X		X						X ⁽⁷⁾	
11	7/16	X ⁽⁴⁾		X				X					
12		X										X ⁽⁶⁾	
	1/2							X ⁽⁵⁾		X		X	
13		X ⁽²⁾		X		(X)							
14		X											X
15		X											
15.5		X											
16	5/8	X						X				X	
	11/16							X					
18		X				X						X	
	3/4							X					
20		X										X	
	13/16							X				X	
22	7/8							X				X	



Wire Rope

FIG. 7

Most Common diameter of wire rope

FIG. 8

Robin Koshy Varghese (INPA No: 3705)
Head, IPR Dept.,
L&T Technology Services Limited,
DLF 3rd Block, 2nd Floor,
Manapakkam, Chennai - 600089.

900
↙
Constructional stretch
for 8 strand fibre core
manufactured wire rope

	Constructional Stretch	Total Stretch
As manufactured wire rope		
6x19 Class with Fibre Core	0.25-0.50%	0.40-0.75%
8x19 Class with Fibre Core	0.50-0.75%	0.70-1.05%
8x19 Class with Steel Core		
9x19 Class with Steel Core	0.30-0.60%	0.45-0.85%
Pre-stretched wire rope		
6x19 Class with Fibre Core	0.10-0.25%	0.25-0.50%
8x19 Class with Fibre Core	0.20-0.35%	0.40-0.65%
8x19 Class with Steel Core		
9x19 Class with Steel Core	0.10-0.30%	0.25-0.60%

FIG. 9

Robin Koshy Varghese (INPA No: 3705)
Head, IPR Dept.,
L&T Technology Services Limited,
DLF 3rd Block, 2nd Floor,
Manapakkam, Chennai - 600089.

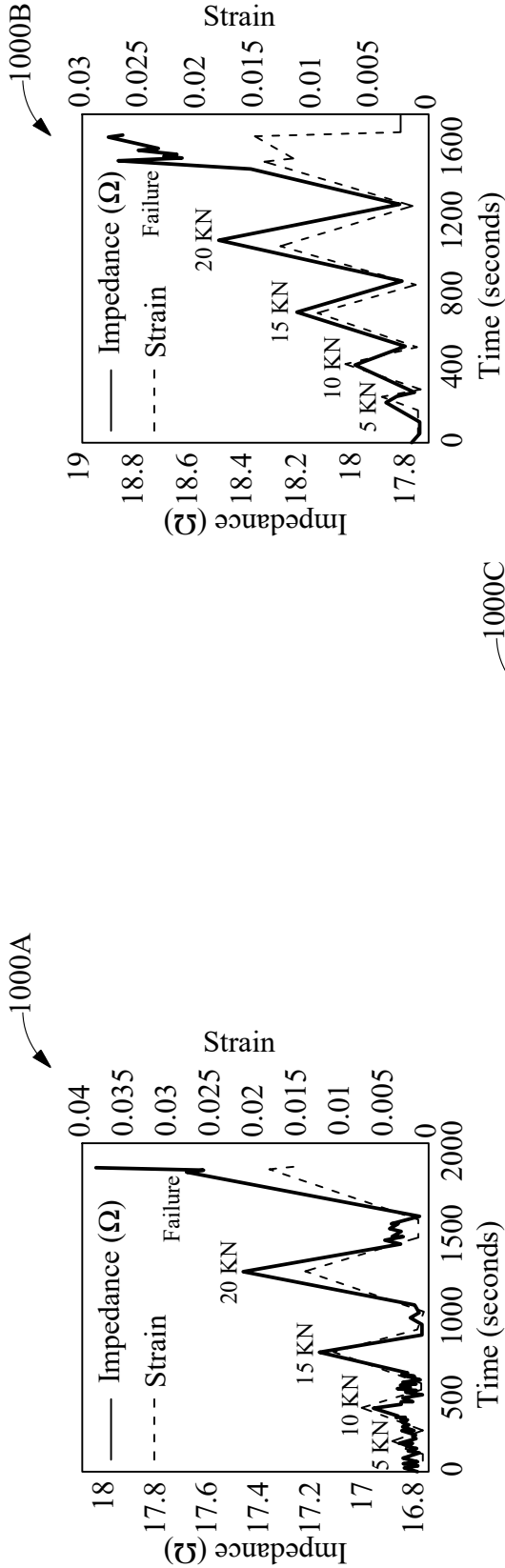

FIG. 10A

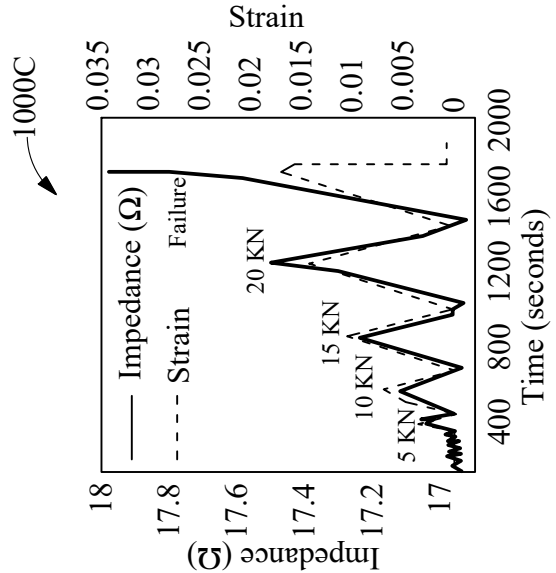

FIG. 10C

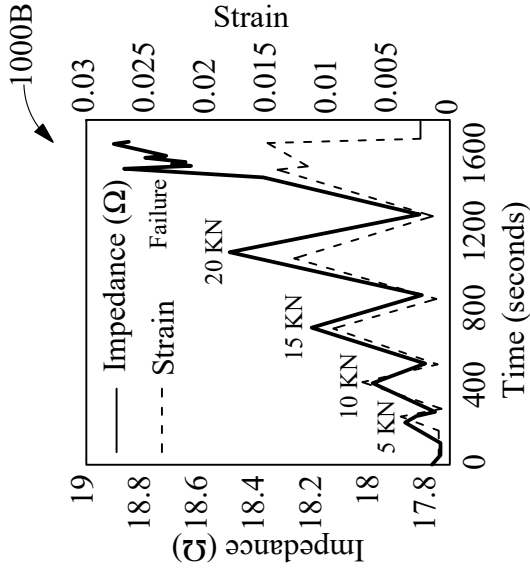

FIG. 10B

Robin Koshy Varghese (INPA No: 3705)
Head, IPR Dept.,
L&T Technology Services Limited,
DLF 3rd Block, 2nd Floor,
Manapakkam, Chennai - 600089.

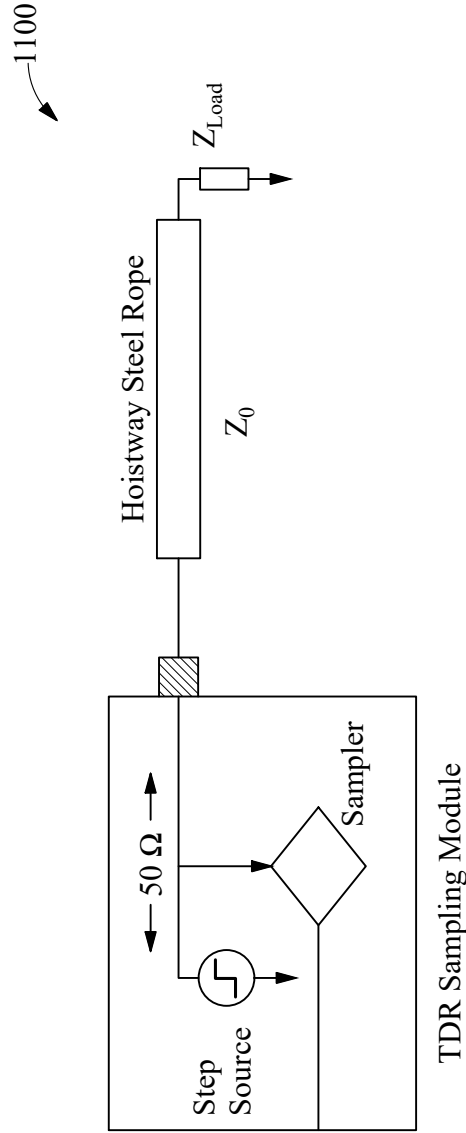

FIG. 11

Robin Koshy Varghese (INPA No: 3705)
Head, IPR Dept.,
L&T Technology Services Limited,
DLF 3rd Block, 2nd Floor,
Manapakkam, Chennai - 600089.

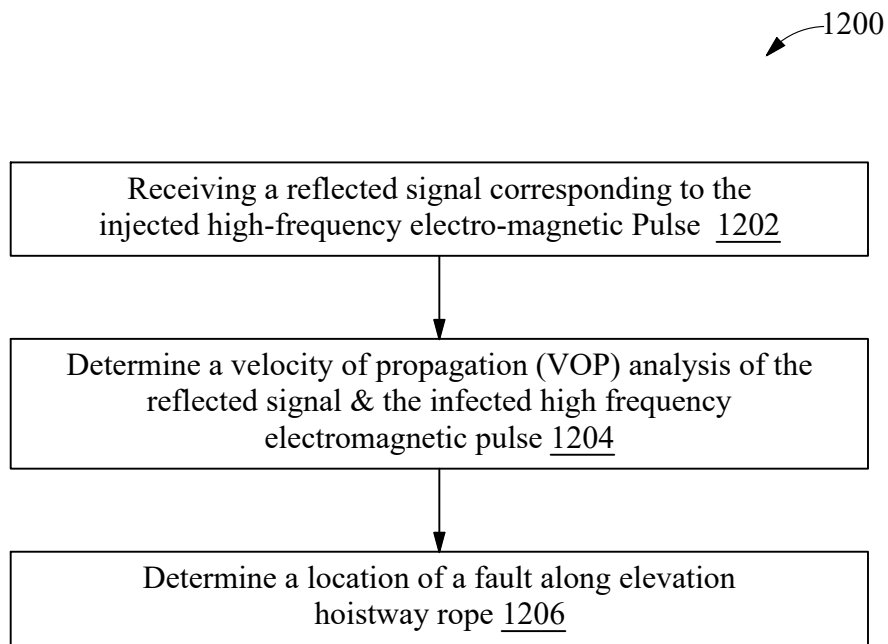

FIG. 12