

(12) Indian Patent Application

(21) Application Number: 202241072572

(22) Filing Date: 15/12/2022 (43) Publication Date: 21/06/2024

(71) Applicant(s): L&T TECHNOLOGY SERVICES LIMITED

(72) Inventor(s): Tiwari, Jai Deo
Pandey, Indu

(51) International Classifications: F04C 25/02 B08B 3/00 B08B 3/14 F04C 18/344 F04C 29/00

(54) Title: SYSTEM FOR MONITORING AND CAPTURING PLASTIC FRAGMENTS

(57) Abstract: This disclosure relates to a system for capturing and monitoring plastic fragments from vehicle tires. The system includes a vacuum pump positioned at an angle to an axle of a vehicle. The vacuum pump is configured to apply a vacuum pressure for absorbing plastic fragments. The system further includes a sensor film coated along an inner surface of the vacuum pump. The sensor film is composed of an Ultraviolet (UV)-responsive graphdiyne-based magnetic photocatalyst with a molecular imprinted memory to capture the plastic fragments and is configured to detect the plastic fragments. The system further includes a solvent container in fluid communication with the vacuum pump. The solvent container includes a washing solvent for removing the plastic fragments from the sensor film, to reuse the sensor. The solvent container releases the washing solvent into the vacuum pump to extract the bound plastic fragments from sensor and regenerate the sensor.

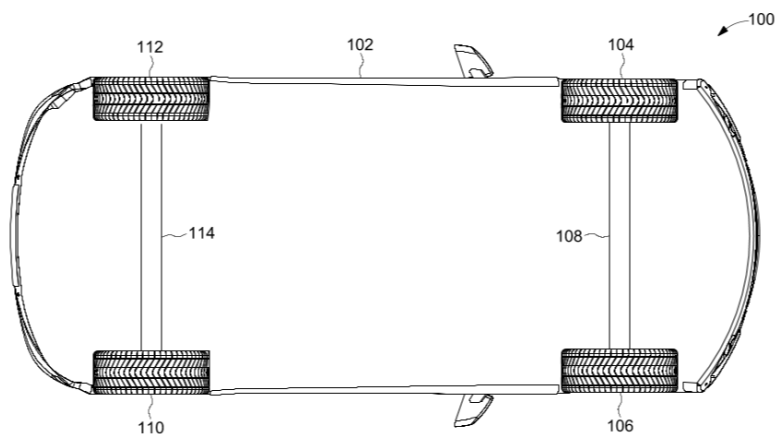

FIG. 1

FORM 2

THE PATENTS ACT 1970
(39 OF 1970)
&
The Patent Rules, 2003

Complete Specification

(See Section 10 and Rule 13)

1. TITLE OF THE INVENTION

SYSTEM FOR MONITORING AND CAPTURING PLASTIC FRAGMENTS

2. APPLICANT(S)

- (a) NAME : **L&T TECHNOLOGY SERVICES LIMITED**
(b) NATIONALITY : **INDIAN**
(c) ADDRESS : **DLF IT SEZ Park, 2nd Floor – Block 3**
1/124, Mount Poonamallee Road,
Ramapuram, Chennai – 600 089,
INDIA.

3. PREAMBLE TO THE DESCRIPTION

COMPLETE

The following specification describes the invention and the manner in which it is to be performed

DESCRIPTION

Technical Field

[001] This disclosure relates generally to plastic capturing systems, and more particularly to a system for monitoring and capturing plastic fragments.

5 Background

[002] A vast majority of vehicle tires are made of synthetic rubber polymers. Upon wearing down, these tires release microplastics and nanoplastics in the environment when they wear down over time. Microplastics and nanoplastics are major pollutants of the environment. About 28 percent of microplastics in the ocean originate from vehicle tires shedding synthetic
10 rubber upon wearing down.

[003] There is, therefore, a need in the present state of art for techniques for capturing and monitoring the plastic fragments released from the tires of a vehicle.

SUMMARY

[004] In one embodiment, a system for capturing plastic fragments is disclosed. In
15 one example, the system may include a vacuum pump positioned at an angle with respect to an axle of a vehicle. The vacuum pump may be configured to apply a vacuum pressure for absorbing the plastic fragments. The system may further include a sensor film coated along an inner surface of the vacuum pump. The sensor film may be composed of an Ultraviolet (UV)-
20 responsive europium (II) graphdiyne-based magnetic photocatalyst with a molecular imprinted memory to capture the plastic fragments. The sensor film may be configured to simultaneously detect the plastic fragments through the molecular imprinted memory. The system may further include a solvent container in fluid communication with the vacuum pump. The solvent container may include a washing solvent for removing the plastic fragments from the sensor film. The solvent container may be configured to release the washing solvent into the vacuum
25 pump to obtain a solution of the plastic fragments in the washing solvent. The system may further include a collection chamber in fluid communication with the vacuum pump. The collection chamber may be configured to collect the solution of the plastic fragments from the vacuum pump.

[005] In one embodiment, a sensor film for detecting plastic fragments is disclosed. In one example, the sensor film may include a graphdiyne-europium-silicon based film coated on a mercaptan-modified quartz crystal. The graphdiyne-europium-silicon based film may be imparted with a molecular imprinted memory to detect the plastic fragments released from a vehicle tire surface.

[006] In one embodiment, a system for monitoring tire health of a vehicle is disclosed. In one example, the system may include a processor and a memory communicatively coupled to the processor. The memory stores processor-executable instructions, which, on execution, may cause the processor to receive in real-time, a set of tire health parameters corresponding to a tire of a vehicle from one or more sensors. The processor-executable instructions, on execution, may further cause the processor to compute at least one performance metric based on the set of tire health parameters using an Artificial Intelligence (AI) model. The AI model may be based on Artificial Neural Network (ANN). The processor-executable instructions, on execution, may further cause the processor to compare each of the at least one performance metric with a predefined target performance metric.

[007] It is to be understood that both the foregoing general description and the following detailed description are exemplary and explanatory only and are not restrictive of the invention, as claimed.

BRIEF DESCRIPTION OF THE DRAWINGS

[008] The accompanying drawings, which are incorporated in and constitute a part of this disclosure, illustrate exemplary embodiments and, together with the description, explain the disclosed principles.

[009] **FIG. 1** illustrates a top schematic view of an exemplary vehicle where embodiments of the present disclosure may be implemented.

[010] **FIG. 2** illustrates a top schematic view of a plastic fragment capturing and monitoring system in an exemplary vehicle, in accordance with some embodiments.

[011] **FIG. 3** illustrates a plastic fragment capturing and monitoring system, in accordance with some embodiments.

[012] **FIG. 4** illustrates a flow diagram of an exemplary process for preparing a sensor film, in accordance with some embodiments.

[013] **FIG. 5** illustrates an exemplary sensor film for detecting plastic fragments, in accordance with some embodiments.

[014] **FIG. 6** illustrates capturing of plastic fragments by a sensor film, in accordance with some embodiments.

[015] **FIGs. 7A and 7B** illustrate experimental results of plastic fragments captured by a sensor film, in accordance with an embodiment.

5 [016] **FIG. 7C** is a graph representing capturing of plastic fragments by a sensor film, in accordance with an embodiment.

[017] **FIG. 8** illustrates a flow diagram of an exemplary process for monitoring tire health of a vehicle, in accordance with some embodiments.

DETAILED DESCRIPTION

10 [018] Exemplary embodiments are described with reference to the accompanying drawings. Wherever convenient, the same reference numbers are used throughout the drawings to refer to the same or like parts. While examples and features of disclosed principles are described herein, modifications, adaptations, and other implementations are possible without departing from the spirit and scope of the disclosed embodiments. It is intended that the
15 following detailed description be considered as exemplary only, with the true scope and spirit being indicated by the following claims.

[019] Referring now to FIG. 1, a top view of an exemplary vehicle 100 where embodiments of the present disclosure may be implemented is illustrated. The vehicle 100 may include a body 102. It may be noted that the vehicle 100 may be motor-driven or mechanically
20 driven. By way of an example, the vehicle 100 may be a car, a truck, a bus, a motorcycle, autos (tricycles) a bicycle, or the like. Further, the vehicle 100 may include a front tire 104 affixed on a first front wheel and a front tire 106 affixed on a second front wheel. The first front wheel may be connected to the second front wheel through a front axle 108. Similarly, the vehicle 100 may include a rear tire 110 affixed on a first rear wheel and a rear tire 112 affixed on a
25 second rear wheel. The first rear wheel may be connected to the second rear wheel through a rear axle 114. It should be noted that in some other embodiments, the vehicle 100 may be a two-wheeler vehicle including a front wheel and a rear wheel where a tire may be affixed on each of the front wheel and the rear wheel. Alternately, the vehicle 100 may be a three-wheeler vehicle including a front wheel and two rear wheels adjoined by an axle. Each of the tires 104,
30 106, 110, and 112 may be composed of one or more synthetic rubber polymers (such as, butadiene rubber, styrene butadiene rubber, etc.).

[020] The vehicle 100 may be configured to move on a surface (e.g., a road, a track, or a rocky terrain). This movement is facilitated by the tires 104, 106, 110, and 112. As will be appreciated, upon each movement of the vehicle 200, each of the tires 104, 106, 110, and 112 may encounter a frictional force from the surface. Due to the frictional force, the tires 104, 106, 110, and 112 start wearing out. It should be noted that upon wearing out, plastic fragments may be released from surface of the tires 104, 106, 110, and 112. It may be noted that size of the plastic fragments may be in a range of about 1 nanometer to about 5 millimeters. The plastic fragments may be in form of microplastics (less than 5 millimeters in diameter) or nanoplastics (about 1 nm to about 100 nm in size) and may be of airborne or floating nature.

[021] Referring now to FIG. 2, a top schematic view of a plastic fragment capturing and monitoring system in an exemplary vehicle 200 is illustrated, in accordance with some embodiments. The vehicle 200 may include the body 102, the front tire 104, the second tire 106, the axle 108, the rear tire 110, the rear tire 112, and the rear axle 114 positioned in a similar arrangement to that of the vehicle 100. The plastic fragment capturing and monitoring system may include a pump 202, a sensor 204, a collector 206, and a solvent container 208. The sensor 204 may be communicatively coupled with the pump 202. Further, the pump 202 may be in fluid communication with the solvent container 208 via a pipe 210 and may be in fluid communication with the collector 206 via a pipe 212. The solvent container 208 may be configured to release a washing solvent into the pump 202 via the pipe 210 to obtain a solution of the plastic fragments in the washing solvent. Further, the pump 202 may deliver the solution into the collector 206 via the pipe 212 where the solution may be stored or treated to produce value added-products.

[022] The plastic fragment capturing and monitoring system may be configured to capture and monitor plastic fragments released from surface of the tires 104, 106, 110, and 112 of the vehicle 200. In an embodiment, the plastic fragment capturing, and monitoring system may be positioned in proximity to the tires 104, 106, 110, and 112. Alternately, the vehicle 200 may include two plastic fragment capturing and monitoring systems, where one plastic fragment capturing, and monitoring system may be installed for each of the axles 108 and 114. In such embodiments, the pump 202 of each of the two systems may be positioned at an angle with respect to an axle of the vehicle 200.

[023] In some embodiments, the pump 202 may be a vacuum pump. The pump 202 may be configured to apply a suction pressure to capture the plastic fragments released from the surface of at least one of the tires 104, 106, 110, and 112 of the vehicle 200. Further, the

pump 202 may include a sensor film (not shown in figure) coated on an inner surface of the pump 202. The sensor film may adsorb the captured plastic fragments.

[024] Further, the sensor 204 may detect and quantify the adsorbed plastic fragments. For example, the sensor 204 may be a UV sensor, a magnetic sensor, a UV sensor, an electronic impedance sensor, an electrochemical sensor, or the like. The plastic fragments may include, but may not be limited to, microplastics and nanoplastics based on size of the plastic fragments. The plastic fragments may be purely or partially composed of a plastic compound (for example, 6-phenylenediamine (6PPD)-quinone, butadiene-styrene, butadiene, Acrylonitrile butadiene styrene (ABS), or the like). FIG. 2 is further explained in conjunction with FIG. 3.

[025] Referring now to FIG. 3, a plastic fragment capturing, and monitoring system is illustrated, in accordance with some embodiments. The plastic fragment capturing and monitoring system may be installed in a vehicle (such as, the vehicle 200). The plastic fragment capturing and monitoring system may include the pump 202, the collector 206, and the solvent container 208. The pump 202 may be positioned at an angle with respect to the axle 108 flanked by the tires 104 and 106 on either side of the vehicle 200.

[026] The pump 202 may include a suction end, a body, and a discharge end. In some embodiments, the pump 202 may be a vacuum pump. The pump 202 may be configured to apply a suction pressure to capture the plastic fragments released from the surface of at least one of the tires 104 and 106 of the vehicle. The pump 202 attracts and collects the plastic fragments from the suction end.

[027] The sensor film 302 may be applied on an inner surface of the body of the pump 202. It may be noted that the sensor film 302 may be flexible and may be heat-resistant and cold-resistant. The sensor film 302 may be an Ultraviolet (UV)-responsive graphdiyne-based magnetic photocatalyst with a molecular imprinted memory to capture the plastic fragments. In an embodiment, the sensor film 302 may be an Ultraviolet (UV)-responsive graphdiyne-based $\text{Fe}_2\text{O}_3/\text{TiO}_2/\text{Pt}$ magnetic photocatalyst including Fe_2O_3 , TiO_2 , Pt, and graphdiyne in a ratio of about 1:1:1:2 by molar mass. The sensor film 302 may be as small as about 1 mm X 1 mm in size. The sensor film as disclosed is capable of sensing microplastics having a particle size of more than 5mm in diameter and nanoplastics having a particle size in the range of about 1 nm to about 100 nm.

[028] The molecular imprinted memory may be imparted on the sensor film 302 through molecular imprinting technology. Templates specific to each of one or more types of

plastic fragments may be used to make a corresponding molecular pocket on the sensor film 302. Each of the one or more type of plastic fragments may bind specifically to the corresponding molecular pocket. The sensor film 302 may adsorb the plastic fragments through the molecular pockets. High resolution signals may be obtained corresponding to each of the one or more type of plastic fragments. In an embodiment, the sensor film 302 may function in a temperature range of about -20 °C to about 300 °C.

[029] Additionally, a set of sensors 304, 306, and 308 may be attached to the sensor film 302 and may be configured to detect and quantify the adsorbed plastic fragments. It may be noted that each of the set of sensors 304, 306, and 308 may be analogous to the sensor 204. The set of sensors 304, 306, and 308 may include a UV sensor, a magnetic sensor, a UV sensor, an electronic impedance sensor, an electrochemical sensor, and the like.

[030] The solvent container 208 may contain a washing solvent for removing the plastic fragments from the sensor film inside the pump 202. In some embodiments, the washing solvent may include acetone and isopropyl alcohol. In a preferred embodiment, the washing solvent may include 0.1M acetone and 0.1M isopropyl alcohol. The solvent container 208 may be a tank attached to the vehicle 200 or a spraying device configured to spray the washing solvent on the plastic fragments. Further, upon detection of the plastic fragments by the set of sensors 304, 306, the solvent container 208 may be configured to release the washing solvent into the pump 202 via the pipe 210. The pump 202 may receive the washing solvent from the solvent container 208 through the discharge end. Upon interacting with the washing solvent, the adsorbed plastic fragments may be removed from the sensor film 302 and a solution of the plastic fragments in the washing solvent may be obtained.

[031] Further, the pump 202 may deliver the solution into the collector 206 via the pipe 212 from the discharge end. In some embodiments, the collector 206 may be configured to store the solution of the plastic fragments. The solution may later be manually discarded (for example, upon receiving a user command to discard the solution) or automatically discarded (for example, when a threshold volume of the solution is collected).

[032] In some other embodiments, the collector 206 may be configured to treat the solution of the plastic fragments to obtain useful compounds (e.g., green fuel) or compounds with reduced pollution potential (e.g., biodegradable compounds). For example, methane may be generated from the plastic fragments in the solution through pyrolysis and hydrogenation. Further, synthesis gas may be produced from the methane by steam reforming. Further, methanol may be generated from the synthesis gas through a high-pressure catalytic

conversion. The generated methanol may then be used as a fuel. In an embodiment, the collector 206 and the solvent container 208 may be present as a single container in the vehicle 200.

5 [033] Referring now to FIG. 4, an exemplary process 400 for preparing a sensor film is depicted via a flow chart, in accordance with some embodiments. The process 400 may include coating a graphdiyne-europium-silicon film on a mercaptan-modified quartz crystal, at step 402. Concentration of mercaptan in the mercaptan-modified quartz crystal may be about 0.01 mM. Thickness of the mercaptan-modified quartz crystal may be in a range of about 0.1 mm to about 1 mm. Further, a solution of graphdiyne and europium (ratio of about 1:1 by weight) in dilute ethanol is applied on the mercaptan-modified quartz crystal. The solution of graphdiyne and europium may be dried for about 30 minutes to obtain the coated graphdiyne-europium-silicon film.

15 [034] Further, the process 400 may include depositing a platinum chloride-ruthenium chloride layer on the graphdiyne-europium film through Electrochemical Atomic Layer Deposition (EALD), at step 404. A solution of platinum chloride (about 0.1 mM concentration) and ruthenium chloride (about 0.5 mM concentration) in acetone may be deposited at about 0.25 V for about 120 seconds via the EALD technique to obtain the platinum chloride-ruthenium chloride layer. Further, the process 400 may include providing a titanium dioxide nanotubes layer on the platinum chloride-ruthenium chloride layer via spin coating, at step 406. Spin coating of titanium dioxide nanotubes may be performed at about 1,500 rpm for about 40 seconds. Further, the titanium dioxide nanotubes may be dried at ambient temperature for about 2 hours to obtain the titanium dioxide nanotubes layer.

25 [035] Further, the process 400 may include depositing a ferric oxide layer deposited on the titanium dioxide nanotubes layer via EALD of ferric chloride and boric acid solution, at step 408. EALD of ferric chloride and boric acid may be performed at a pH of about 4.0 for about 700 seconds to obtain a film. The film may then be separated to allow formation of the ferric oxide layer. Structure of the sensor film is further elaborated in conjunction with FIG. 5.

30 [036] Referring now to FIG. 5, an exemplary sensor film 500 for detecting plastic fragments is depicted via a flow chart, in accordance with some embodiments. It may be noted that the sensor film 500 may be analogous to the sensor film 302. The sensor film 500 may include a mercaptan-modified quartz crystal 502 in an embodiment, thickness of the mercaptan-modified quartz crystal 502 may be in a range of about 0.1 mm to about 1 mm. Additionally, a graphdiyne-europium-silicon based film 504 may be coated on the mercaptan-modified quartz

crystal 502. Further, a platinum chloride-ruthenium chloride layer 506 may be deposited on the graphdiyne-europium film 504 through EALD. Further, a titanium dioxide nanotubes layer 508 may be provided on the platinum chloride-ruthenium chloride layer 506 via spin coating. Further, a ferric oxide layer 510 may be deposited on the titanium dioxide nanotubes layer 508 via EALD of ferric chloride and boric acid solution.

[037] Thickness of the sensor film 500 may be in a range of about 3 nm to about 5 nm. The sensor film 500 may be luminescent with high magnetism, a UV light response, and electrochemical properties so as to allow detection and identification of plastic fragments in different modes (e.g., luminescent, magnetism, and electrochemical signals) by one or more sensors (such as, the set of sensors 304, 306, and 308).

[038] Referring now to FIG. 6, capturing of plastic fragments by a sensor film 602 is illustrated, in accordance with some embodiments. The sensor film 602 may be structurally similar to the sensor film 500. The graphdiyne-europium-silicon based electrodeposition on the sensor film 602 may adsorb plastic fragments 604, 606, and 608 (for example, 6PPD quinone, butadiene-styrene, and butadiene) at 0.25 V for 15 minutes. The plastic fragments 604, 606, and 608 may then be extracted and stripped by subjecting the sensor film to 0.25 V for 10 minutes using a washing solvent to regenerate the sensor film 602 and to obtain a solution of the plastic fragments 604, 606, and 608 in the washing solvent.

[039] Upon regenerating the sensor film 602, empty molecular pockets 610, 612, and 614 may be obtained. Each of the 3D printed molecular pockets 610, 612, and 614, as per the plastic fragments, may be configured to selectively bind to the same plastic fragments. Thus, due to the regeneration capability, the sensor film 602 is reusable and is not limited to one-time use.

[040] Referring now to FIGs. 7A and 7B, experimental results of plastic fragments captured by a sensor film are illustrated, in accordance with an embodiment. In FIG. 7A, a photographic image 700A shows the plastic fragments at $t=0$. In FIG. 7B, a photographic image 700B shows the plastic fragments of 700A after interacting with a sensor film (such as, the sensor film 302). As may be observed, the sensor film captures the plastic fragments and may be separated from using a magnet (as the sensor film exhibits magnetic property).

[041] Referring now to FIG. 7C, a graph 700C representing capturing of plastic fragments by a sensor film is illustrated, in accordance with an embodiment. Response of the sensor film for the plastic fragments may be monitored in terms of current or voltage. The graph 700C shows sensor response in terms of voltage. A peak is obtained corresponding to

each type of plastic compound detected in the captured plastic fragments. The graph 700C shows peaks corresponding to 6PPD-quinone, butadiene-styrene, and butadiene compounds. It should be noted that the sensor film may capture and detect plastic fragments of size less than 100 nm with a sensitivity of at least about 50 ngL⁻¹ in air or water and up to about 1000 mgL⁻¹.

[042] Referring now to FIG. 8, an exemplary process 800 for monitoring tire health of a vehicle is depicted via a flow chart, in accordance with some embodiments. In an embodiment, the process 800 may be implemented via a system such as the plastic fragment capturing and monitoring system of the vehicle 200. The process 800 may include receiving in real-time, a set of tire health parameters corresponding to a tire of a vehicle from one or more sensors, at step 802. By way of an example, the set of tire health parameters may include at least one of pH, tire age, temperature, tire voltage level, sensor adsorption capacity, sensor affinity, and speed of the vehicle. The one or more sensors may include at least one sensor configured to detect and quantify plastic fragments released from a surface of the tire through a graphdiyne-based magnetic photocatalyst sensor film (for example, the sensor film 302) imparted with molecular imprinted memory. By way of an example, the one or more one sensors may be selected from a group including a magnetic sensor, a UV sensor, an electronic impedance sensor, and an electrochemical sensor.

[043] Further, the process 800 may include computing at least one performance metric based on the set of tire health parameters using an Artificial Intelligence (AI) model, at step 804. By way of an example, the at least one performance metric may include at least one of plastic fragments degradation voltage level, a sensor adsorption capacity change, and a sensor affinity change. The AI model is based on Artificial Neural Network (ANN). Further, the process 800 may include comparing each of the at least one performance metric with a predefined target performance metric, at step 806. Further, the process 800 may include estimating a tire health degradation level based on the comparing, at step 808. The AI model may be trained using a training dataset. For example, the training dataset may include a known tire health degradation level corresponding to each of a plurality of values corresponding to each of the set of tire health parameters.

[044] Thus, the disclosed system tries to overcome the technical problem of capturing and monitoring plastic fragments from tires. The system detects plastic fragments with high accuracy and at a high resolution. The system provides a flexible sensor film capable for functioning at a wide temperature range (cold and hot) of about -20 °C to about 300 °C.

The sensor film is thin (about 3-5 nm thickness), luminescent, and has excellent magnetism, UV light response, and electrochemical properties. Further, the system provides an AI model for monitoring tire health and predicting tire degradation levels.

5 [045] As will be appreciated by those skilled in the art, the techniques described in the various embodiments discussed above are not routine, or conventional, or well understood in the art. The techniques discussed above provide for capturing and monitoring plastic fragments from vehicle tires. The techniques may deploy a vacuum pump positioned at an angle to an axle of a vehicle and configured to apply a vacuum pressure for absorbing the plastic fragments. The techniques may further deploy a sensor film coated along an inner
10 surface of the vacuum pump. The sensor film may be composed of an UV-responsive graphdiyne-based magnetic photocatalyst with a molecular imprinted memory to capture the plastic fragments. The sensor film is configured to simultaneously detect the plastic fragments through the molecular imprinted memory. The techniques may further deploy a solvent container in fluid communication with the vacuum pump. The solvent container may include a
15 washing solvent for removing the plastic fragments from the sensor film. The solvent container may be configured to release the washing solvent into the vacuum pump to obtain a solution of the plastic fragments in the washing solvent. The techniques may further deploy a collection chamber in fluid communication with the vacuum pump. The collection chamber may be configured to collect the solution of the plastic fragments from the vacuum pump.

20 [046] In light of the above-mentioned advantages and the technical advancements provided by the disclosed method and system, the claimed steps as discussed above are not routine, conventional, or well understood in the art, as the claimed steps enable the following solutions to the existing problems in conventional technologies. Further, the claimed steps clearly bring an improvement in the functioning of the device itself as the claimed steps provide
25 a technical solution to a technical problem.

[047] The specification has described a system for capturing and monitoring plastic fragments and a sensor film for the same. The illustrated steps are set out to explain the exemplary embodiments shown, and it should be anticipated that ongoing technological development will change the manner in which particular functions are performed. These
30 examples are presented herein for purposes of illustration, and not limitation. Further, the boundaries of the functional building blocks have been arbitrarily defined herein for the convenience of the description. Alternative boundaries can be defined so long as the specified functions and relationships thereof are appropriately performed. Alternatives (including

equivalents, extensions, variations, deviations, etc., of those described herein) will be apparent to persons skilled in the relevant art(s) based on the teachings contained herein. Such alternatives fall within the scope and spirit of the disclosed embodiments.

5 [048] It is intended that the disclosure and examples be considered as exemplary only, with a true scope and spirit of disclosed embodiments being indicated by the following claims.

WE CLAIM:

1. A system for capturing plastic fragments emitted from vehicle tire surface, the system comprising:

a vacuum pump positioned at an angle with respect to an axle of a vehicle, wherein the vacuum pump is configured to apply a vacuum pressure for absorbing the plastic fragments;

one or more sensor films coated along an inner surface of the vacuum pump, wherein for each sensor film of the one or more sensor films, the sensor film is composed of an Ultraviolet (UV)-responsive graphdiyne-based magnetic photocatalyst with a molecular imprinted memory to capture the plastic fragments, and wherein the sensor film is configured to simultaneously detect the plastic fragments through the molecular imprinted memory;

a solvent container in fluid communication with the vacuum pump, wherein the solvent container comprises a washing solvent for removing the plastic fragments from the sensor film, and wherein the solvent container is configured to release the washing solvent into the vacuum pump to obtain a solution of the plastic fragments in the washing solvent; and

a collection chamber in fluid communication with the vacuum pump, wherein the collection chamber is configured to collect the solution of the plastic fragments from the vacuum pump.

2. The system as claimed in claim 1, wherein the collection chamber is further configured to:

generate methane from the plastic fragments in the solution through pyrolysis and hydrogenation;

produce synthesis gas from the methane by steam reforming; and

produce methanol from the synthesis gas through a high-pressure catalytic conversion..

3. The system as claimed in claim 1, wherein the sensor film comprises a graphdiyne-europium-silicon film coated on a mercaptan-modified quartz crystal, and wherein the sensor film further comprises:

a platinum chloride-ruthenium chloride layer deposited on the graphdiyne-europium film through Electrochemical Atomic Layer Deposition (EALD);

a titanium dioxide nanotubes layer provided on the platinum chloride-ruthenium chloride layer via spin coating; and

a ferric oxide layer deposited on the titanium dioxide nanotubes layer via EALD of ferric chloride and boric acid solution.

4. The system as claimed in claim 1, wherein the sensor film is further configured to quantify the plastic fragments through at least one sensor selected from a group comprising a magnetic sensor, a UV sensor, an electronic impedance sensor, and an electrochemical sensor, wherein molecular pockets of the sensor film are regenerated by the washing solvent, and wherein the washing solvent comprises acetone and isopropyl alcohol.

5. The system as claimed in claim 1, wherein size of the plastic fragments is in a range of about 1 nanometer to about 5 millimeters.

6. A sensor film for detecting plastic fragments, the sensor film comprising:

a graphdiyne-europium-silicon based film coated on a mercaptan-modified quartz crystal, wherein the graphdiyne-europium-silicon based film is imparted with a molecular imprinted memory to detect the plastic fragments released from a vehicle tire surface.

7. The sensor film as claimed in claim 6, further comprising:

a platinum chloride-ruthenium chloride layer deposited on the graphdiyne-europium film through Electrochemical Atomic Layer Deposition (EALD);

a titanium dioxide nanotubes layer provided on the platinum chloride-ruthenium chloride layer via spin coating; and

a ferric oxide layer deposited on the titanium dioxide nanotubes layer via EALD of ferric chloride and boric acid solution.

8. The sensor film as claimed in claim 7, further comprising an $\text{Fe}_2\text{O}_3/\text{TiO}_2/\text{Pt}/\text{Ru}$ -graphdiyne-europium-silicon film coated on the mercaptan-modified quartz crystal, and configured to:

simultaneously capture the plastic fragments released from a tire of a vehicle via the molecular imprinted memory; and

quantify the plastic fragments released from the tire of the vehicle through at least one sensor selected from a group comprising a magnetic sensor, an Ultraviolet (UV) sensor, an electronic impedance sensor and an electrochemical sensor.

9. The sensor film as claimed in claim 6, further configured to:

determine a set of tire health parameters through the at least one sensor, wherein the set of tire health parameters comprises at least one of pH, tire age, temperature, tire voltage level, sensor adsorption capacity, sensor affinity, and speed of the vehicle;

determine at least one performance metric based on the set of tire health parameters, wherein the at least one performance metric comprises at least one of plastic fragments degradation voltage level, a sensor adsorption capacity change, and a sensor affinity change;

compare each of the at least one performance metric with a predefined target performance metric; and

estimate a tire health degradation level based on the comparison.

10. The sensor film as claimed in claim 6, wherein size of the plastic fragments is in a range of about 1 nanometer to about 5 millimeters.

Dated this 15th day of December 2022

-- Digitally Signed--

Bhanu Prasad
(INPA No: **3253**)
Head, IPR Dept.,
L&T Technology Services Limited,
DLF 3rd Block, 2nd Floor,
Manapakkam, Chennai - 600089.

ABSTRACT

SYSTEM FOR MONITORING AND CAPTURING PLASTIC FRAGMENTS

This disclosure relates to a system for capturing and monitoring plastic fragments from vehicle tires. The system includes a vacuum pump positioned at an angle to an axle of a vehicle. The vacuum pump is configured to apply a vacuum pressure for absorbing plastic fragments. The system further includes a sensor film coated along an inner surface of the vacuum pump. The sensor film is composed of an Ultraviolet (UV)-responsive graphdiyne-based magnetic photocatalyst with a molecular imprinted memory to capture the plastic fragments and is configured to detect the plastic fragments. The system further includes a solvent container in fluid communication with the vacuum pump. The solvent container includes a washing solvent for removing the plastic fragments from the sensor film, to reuse the sensor. The solvent container releases the washing solvent into the vacuum pump to extract the bound plastic fragments from sensor and regenerate the sensor.

[To be published with FIG. 2]

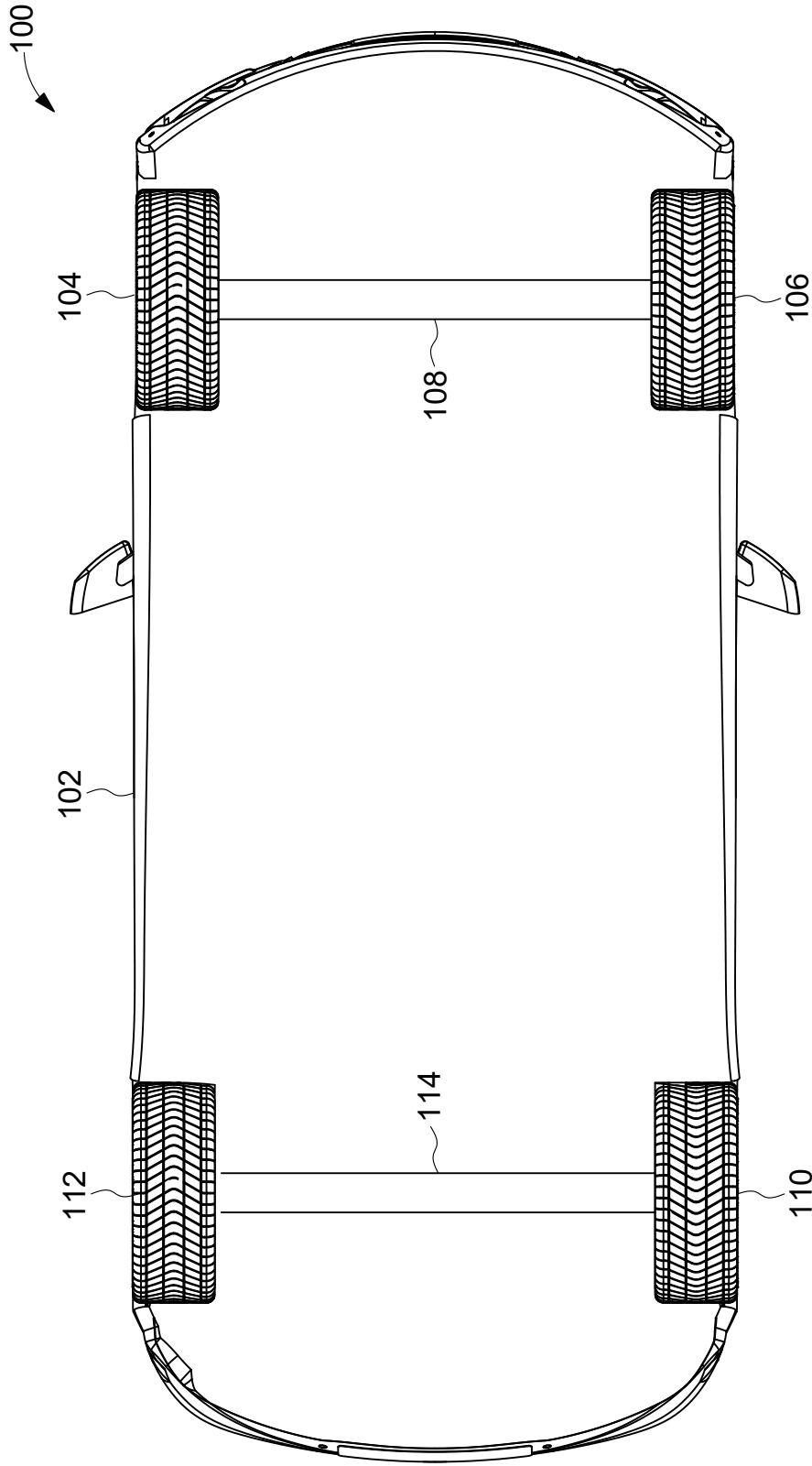

FIG. 1

-- Digitally Signed--

Bhanu Prasad
(INPA No: 3253)
Head, IPR Dept.,
L&T Technology Services Limited,
DLF 3rd Block, 2nd Floor,
Manapakkam, Chennai - 600089.

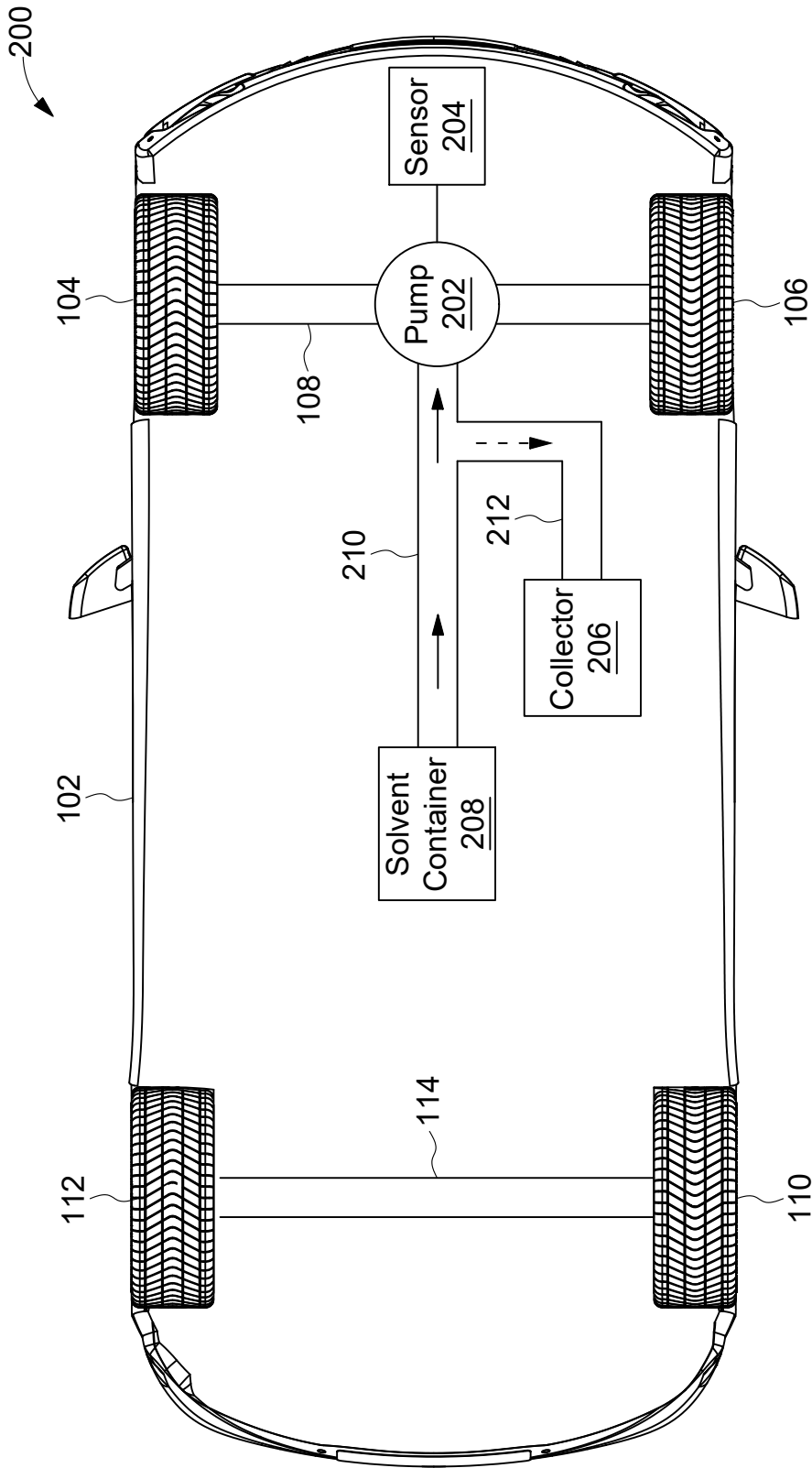

FIG. 2

-- Digitally Signed--

Bhanu Prasad
(INPA No: 3253)
Head, IPR Dept.,
L&T Technology Services Limited,
DLF 3rd Block, 2nd Floor,
Manapakkam, Chennai - 600089.

3/8

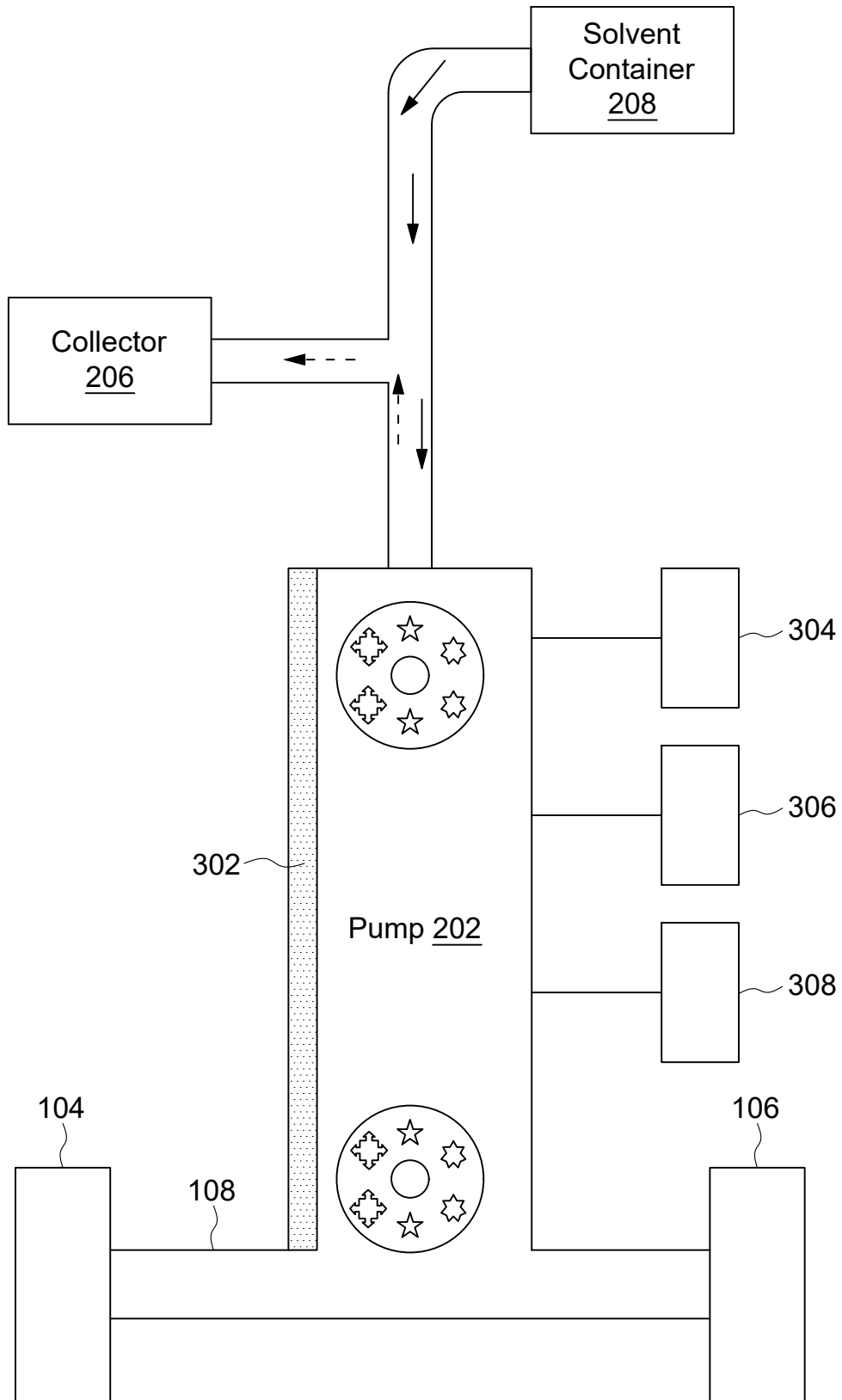

FIG. 3

-- Digitally Signed--

Bhanu Prasad
(INPA No: 3253)
Head, IPR Dept.,
L&T Technology Services Limited,
DLF 3rd Block, 2nd Floor,
Manapakkam, Chennai - 600089.

4/8

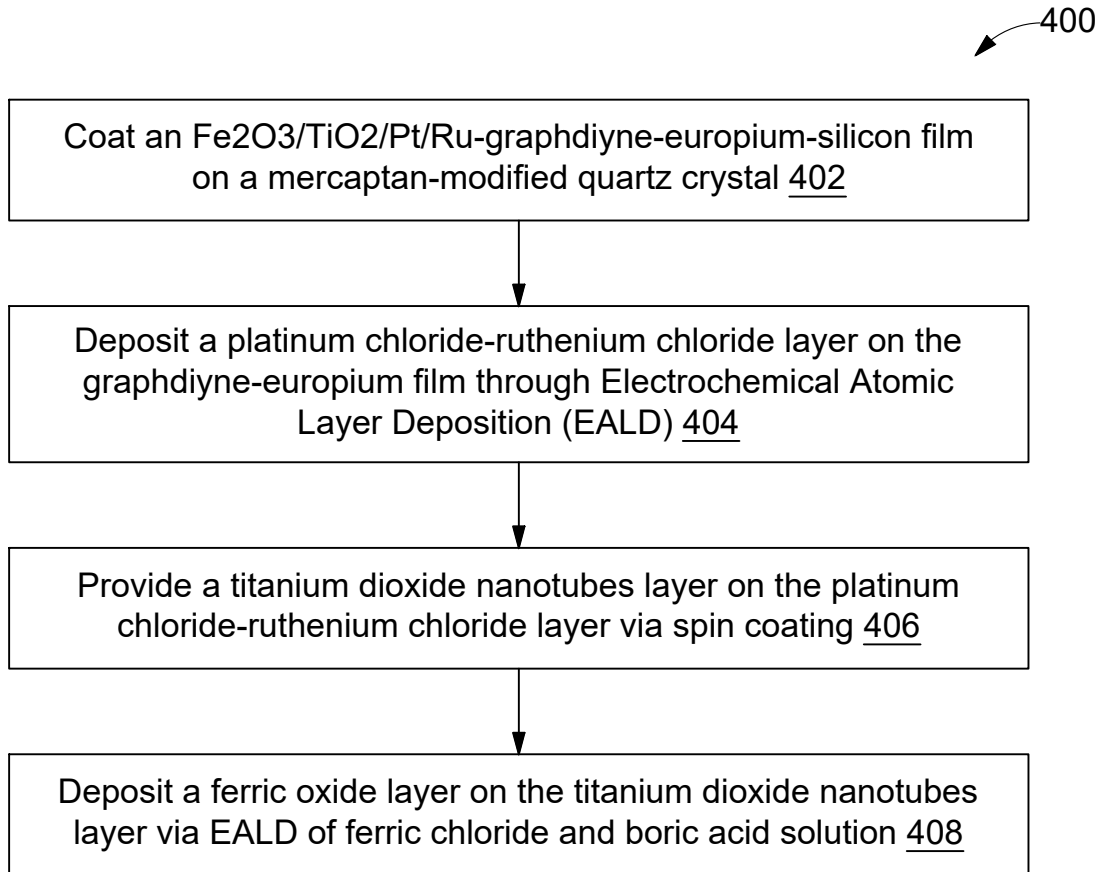

FIG. 4

-- Digitally Signed--

Bhanu Prasad
(INPA No: 3253)
Head, IPR Dept.,
L&T Technology Services Limited,
DLF 3rd Block, 2nd Floor,
Manapakkam, Chennai - 600089.

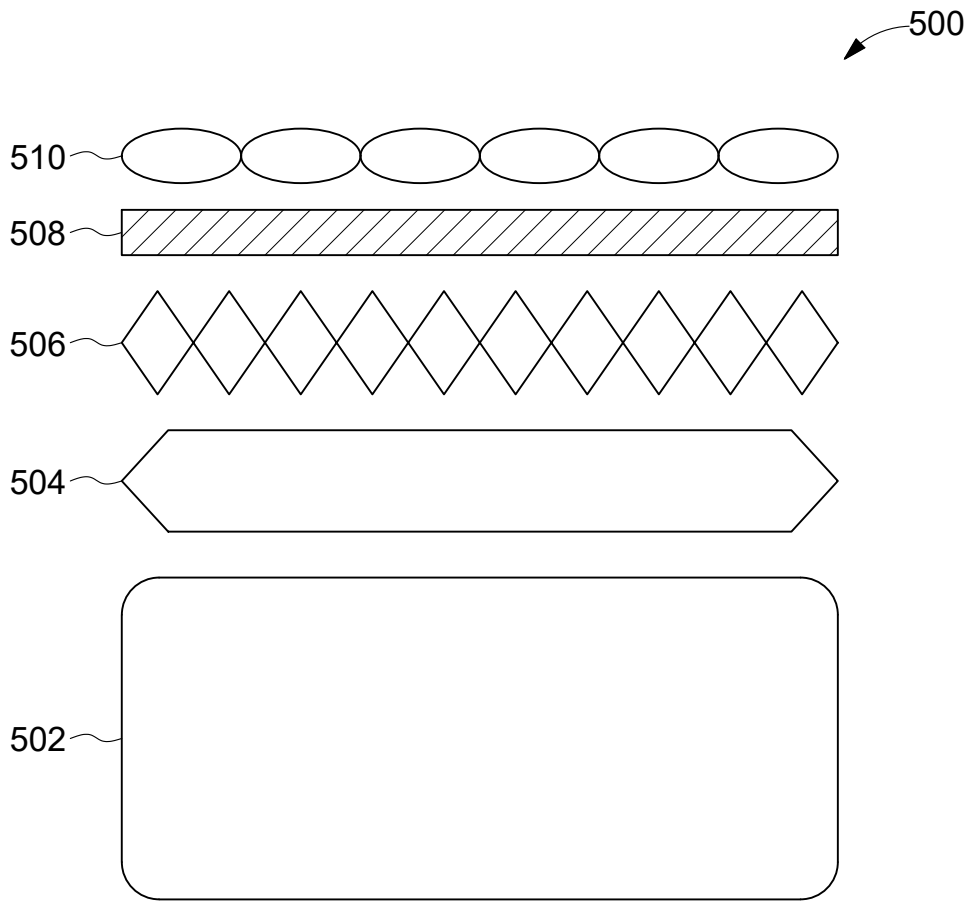

FIG. 5

-- Digitally Signed--

Bhanu Prasad
(INPA No: 3253)
Head, IPR Dept.,
L&T Technology Services Limited,
DLF 3rd Block, 2nd Floor,
Manapakkam, Chennai - 600089.

6/8

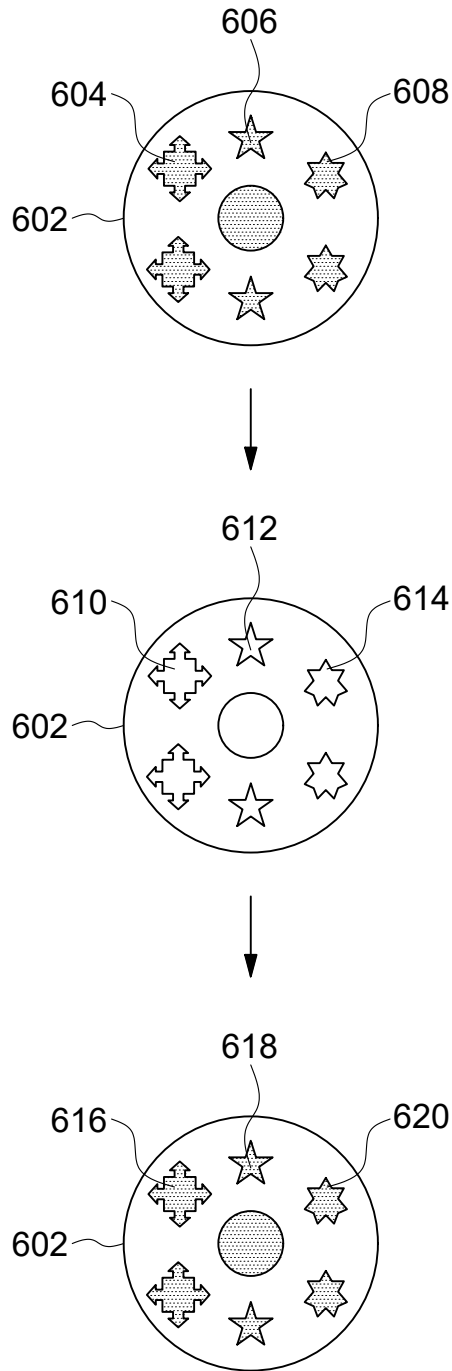

FIG. 6

-- Digitally Signed--

Bhanu Prasad
(INPA No: 3253)
Head, IPR Dept.,
L&T Technology Services Limited,
DLF 3rd Block, 2nd Floor,
Manapakkam, Chennai - 600089.

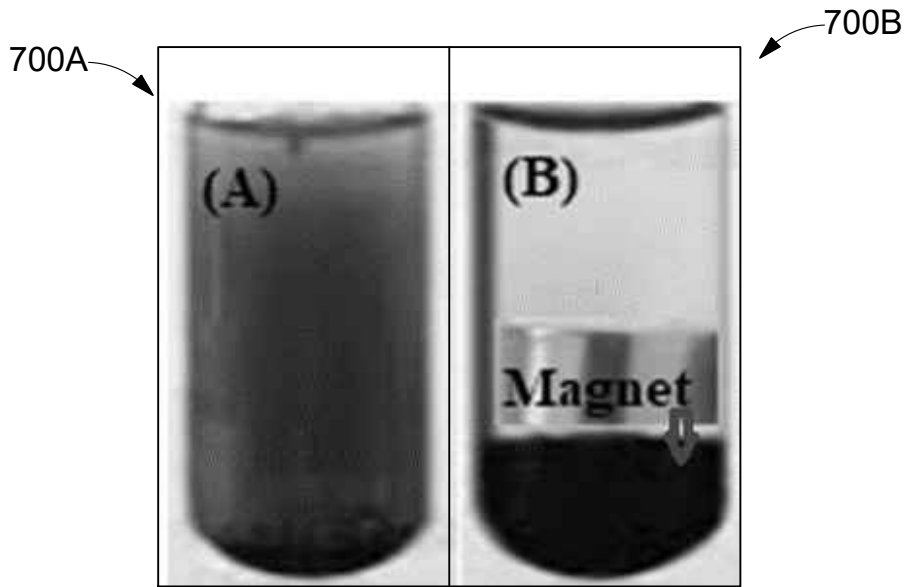

FIG. 7A

FIG. 7B

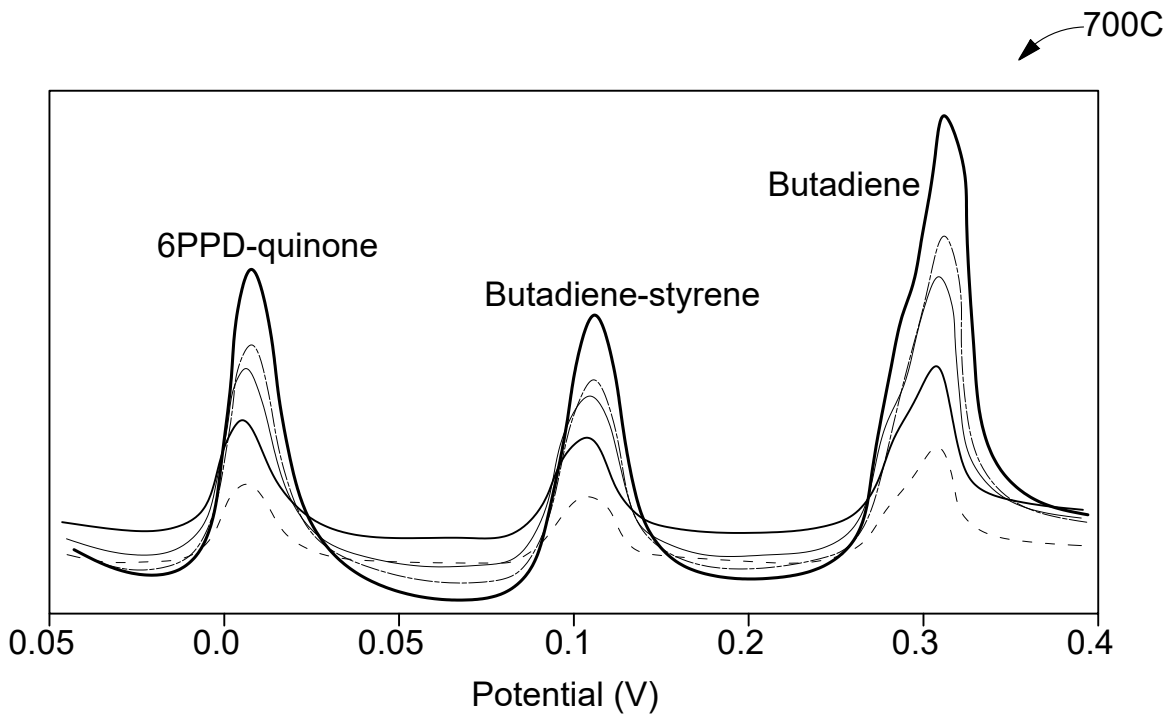

FIG. 7C

-- Digitally Signed--

Bhanu Prasad
(INPA No: 3253)
Head, IPR Dept.,
L&T Technology Services Limited,
DLF 3rd Block, 2nd Floor,
Manapakkam, Chennai - 600089.

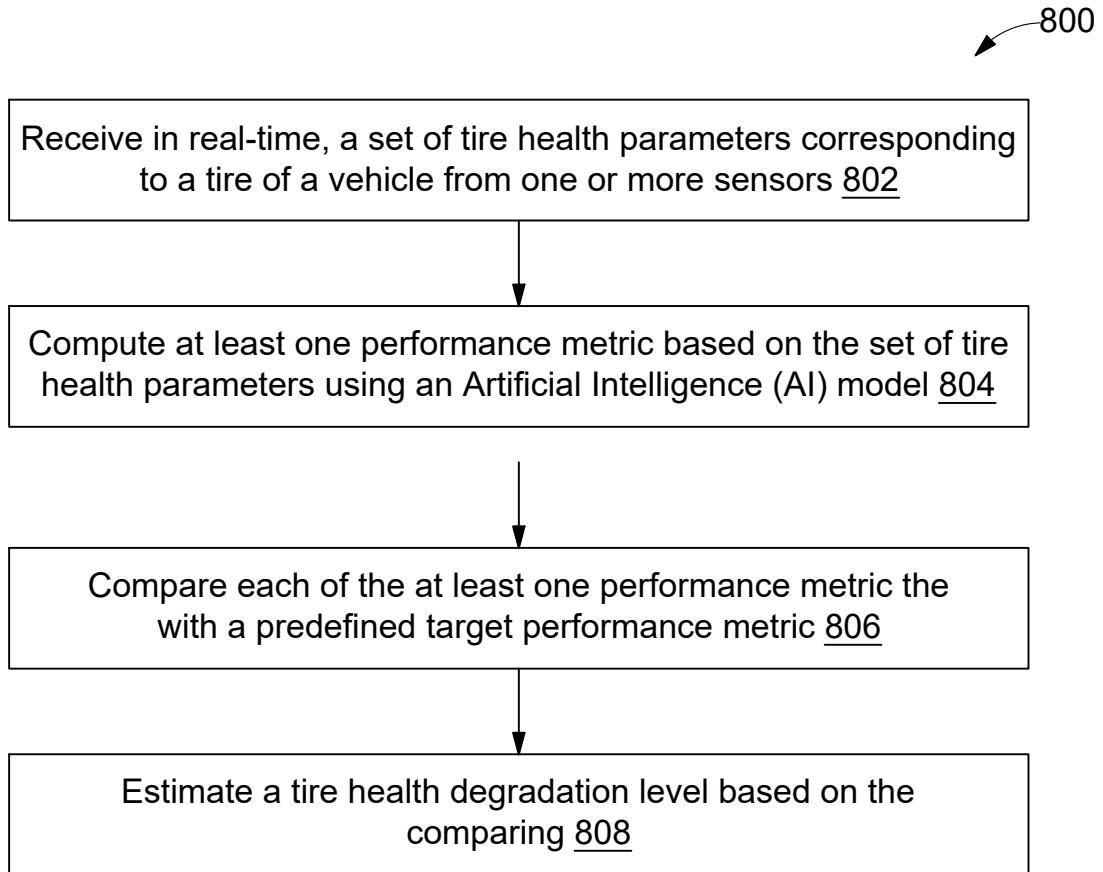

FIG. 8

-- Digitally Signed--

Bhanu Prasad
(INPA No: 3253)
Head, IPR Dept.,
L&T Technology Services Limited,
DLF 3rd Block, 2nd Floor,
Manapakkam, Chennai - 600089.