

(12)Indian Patent Application

(21) Application Number: 202341018216

(22) Filing Date: 17/03/2023 (43) Publication Date: 20/09/2024

(71) Applicant(s): L T TECHNOLOGY SERVICES LIMITED

(72) Inventor(s): Anthony, Madhan
Muthuperumal, Siva Pallipalayam

(51) International Classifications: G06N 3/08 F02D 41/14 G06F 11/07 A61B 5/00 G06T 11/00

(54) Title: METHOD AND SYSTEM FOR DETERMINING GAS LEAKAGE IN AN ACCUMULATOR

(57) Abstract: This disclosure relates to method (700) and system (100) for determining gas leakage in an accumulator. The method includes receiving (702), from a plurality of sensors, one or more parameters of a pre-charge gas accommodated within the accumulator along with corresponding timeseries data (214) indicating a time of detection of each of the one or more parameters. The method (700) further includes determining (704) a change in molar mass of the pre-charge gas based on the timeseries data (214) using a physics-based model (202). The method (700) further includes determining (712) an information associated with a pre-charge gas pressure based on the timeseries data (214) using a deep learning model (204). The method further (700) includes predicting (714) a cause of failure of the accumulator based on the determination of the change in the molar mass and the information.

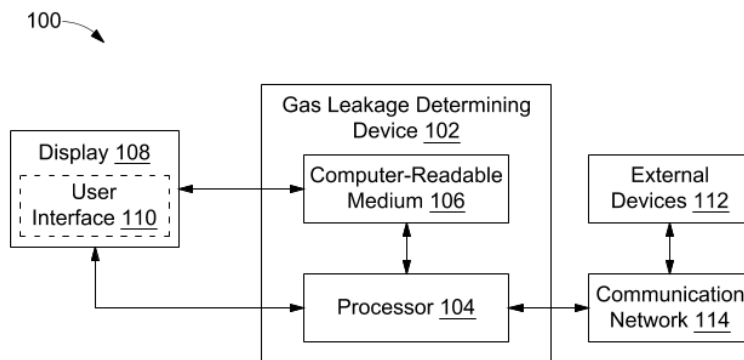

FIG. 1

FORM 2

THE PATENTS ACT 1970
(39 OF 1970)

&

The Patent Rules, 2003

Complete Specification

(See Section 10 and Rule 13)

1. TITLE OF THE INVENTION

**METHOD AND SYSTEM FOR DETERMINING GAS LEAKAGE IN AN
ACCUMULATOR**

2. APPLICANT(S)

(a) NAME : **L&T TECHNOLOGY SERVICES LIMITED**

(b) NATIONALITY : **INDIAN**

(c) ADDRESS : **DLF IT SEZ Park, 2nd Floor – Block 3**

1/124, Mount Poonamallee Road,

Ramapuram, Chennai – 600 089,

INDIA.

3. PREAMBLE TO THE DESCRIPTION

COMPLETE

The following specification describes the invention and the manner in which it is to be
performed

DESCRIPTION

Technical Field

[001] This disclosure relates generally to Internet of Things (IoT), and more particularly to method and system for determining gas leakage in an accumulator.

5 Background

[002] Gas accumulators undergoing repeated compression cycles and remaining idle over a period have a tendency to lose some amount of gas over time. Such leakage of gas leads to reduction in elastic energy of the accumulators. The most common application of the accumulator is in wind turbines that use a hydraulic pitch system to perform emergency
10 stopping of the blade. The accumulator shall assist in performing functions such as, controlling production, reducing forces on turbine (i.e., tilt and yaw control), and aerodynamic braking as a part of turbine protection system.

[003] A study on failures of wind turbine revealed that accumulators alone account for 10% of the total wind turbine failure rate. One of the main causes of failure is due to leakage of gas,
15 which reduces the energy storing capacity of the accumulators. Monitoring the accumulator leakage could serve as a valuable input for condition based preventive maintenance with the objective to increase the systems availability. In the present state of art, techniques for accurately monitoring and calculating gas leakage do not exist. There is, therefore, a need in the present state of art for techniques to monitor and calculate accumulator gas leakage in real-
20 time.

SUMMARY

[004] In one embodiment, a method for determining gas leakage in an accumulator is disclosed. In one example, the method includes receiving, from a plurality of sensors, one or more parameters of a pre-charge gas accommodated within the accumulator along with
25 corresponding timeseries data indicating a time of detection of each of the one or more parameters. The method further includes determining a change in molar mass of the pre-charge gas based on the timeseries data using a physics-based model. The method further includes determining an information associated with a pre-charge gas pressure based on the timeseries data using a deep learning model. The method further includes predicting failure of
30 accumulator based on the determination of the change in the molar mass and the information.

[005] In one embodiment, a system for determining gas leakage in an accumulator is disclosed. In one example, the system includes a processor and a computer-readable medium communicatively coupled to the processor. The computer-readable medium store processor-executable instructions, which, on execution, cause the processor to receive, from a plurality of sensors, one or more parameters of a pre-charge gas accommodated within the accumulator along with corresponding timeseries data indicating a time of detection of each of the one or more parameters. The processor-executable instructions, on execution, further cause the processor to determine a change in molar mass of the pre-charge gas based on the timeseries data using a physics-based model. The processor-executable instructions, on execution, further cause the processor to determine an information associated with a pre-charge gas pressure based on the timeseries data using a deep learning model. The processor-executable instructions, on execution, further cause the processor to predict a cause of failure of accumulator based on the determination of the change in the molar mass and the information.

[006] It is to be understood that both the foregoing general description and the following detailed description are exemplary and explanatory only and are not restrictive of the invention, as claimed.

BRIEF DESCRIPTION OF THE DRAWINGS

[007] The accompanying drawings, which are incorporated in and constitute a part of this disclosure, illustrate exemplary embodiments and, together with the description, serve to explain the disclosed principles.

[008] FIG. 1 is a block diagram of an exemplary system for determining gas leakage in an accumulator, in accordance with some embodiments.

[009] FIG. 2 illustrates a functional block diagram of a gas leakage determining device implemented by the exemplary system of FIG. 1, in accordance with some embodiments.

[010] FIG. 3 illustrates a simulation model of a system for determining gas leakage in a gas accumulator, in accordance with an embodiment.

[011] FIG. 4 illustrates a simulation model of a sub-system for determining gas leakage in a gas accumulator, in accordance with an embodiment.

[012] FIG. 5 illustrates a simulation model of a gas accumulator, in accordance with an embodiment.

[013] FIG. 6 illustrates training of a predictive model for determining gas leakage in an accumulator, in accordance with some embodiments.

[014] FIG. 7 illustrates a flow diagram of an exemplary process for determining gas leakage in an accumulator, in accordance with some embodiments.

[015] FIG. 8 illustrates a flow diagram of a detailed exemplary process of implementing a model-based profile comparator, in accordance with some embodiments.

5 [016] FIG. 9 illustrates a flow diagram of a detailed exemplary control logic for implementing a model-based profile comparator in run-time, in accordance with some embodiments.

[017] FIG. 10 illustrates a simulation model of a model-based profile comparator, in accordance with an embodiment.

[018] FIG. 11 illustrates a flow diagram of a detailed exemplary process of manual feature
10 extraction using Machine Learning (ML), in accordance with some embodiments.

[019] FIG. 12 is a set of graphs representing flow rate and pressure comparison of a model-based accumulator with a real accumulator, in accordance with an embodiment.

[020] FIG. 13 is a set of graphs representing Multiresolution Signal Decomposition (MSD) coefficients at various levels, in accordance with an embodiment.

15 [021] FIG. 14 is a graph representing prediction of volume of gas in an accumulator using a deep learning model, in accordance with an embodiment.

[022] FIG. 15 is a block diagram of an exemplary computer system for implementing embodiments consistent with the present disclosure.

DETAILED DESCRIPTION

20 [023] Exemplary embodiments are described with reference to the accompanying drawings. Wherever convenient, the same reference numbers are used throughout the drawings to refer to the same or like parts. While examples and features of disclosed principles are described herein, modifications, adaptations, and other implementations are possible without departing from the spirit and scope of the disclosed embodiments. It is intended that the following
25 detailed description be considered as exemplary only, with the true scope and spirit being indicated by the following claims.

[024] Referring now to FIG. 1, an exemplary system 100 for determining gas leakage in an accumulator is illustrated, in accordance with some embodiments. The accumulator may be a gas accumulator including a bladder and at least one chamber. One of the at least one chamber
30 includes a gas (such as, Nitrogen gas or any other inert gas). The system 100 may implement a gas leakage determining device 102 (for example, server, desktop, laptop, notebook, netbook, tablet, smartphone, mobile phone, or any other computing device), in accordance with some

embodiments of the present disclosure. The gas leakage determining device 102 implements a method to estimate the molar mass of a pre-charge gas in the accumulator at any instant of time and to detect a broken bladder along with making test data available.

5 [025] The gas leakage determining device 102 may receive one or more parameters of a pre-charge gas in the accumulator from a plurality of sensors. By way of an example, the one or more parameters may include pre-charge pressure (bar), pre-charge temperature (K), accumulator volume (L), accumulator flow (LPM), real gas constant for BWR equation, process noise, measurement noise, initial estimate for mass (determined), volume of the gas –
10 (validation), pressure of the gas - time (validation), temperature of the gas – time (validation), thermal time constant (validation), pressure – time for different pre-charge pressure, heat transfer coefficient (W/m²K), radius / height of the bladder/accumulator, nitrogen gas properties, and the like. The gas leakage determining device 102 may then calculate a change in molar mass of the pre-charge gas accommodated within the accumulator and an information associated with a pre-charge gas pressure using the one or more parameters.
15 The information may include pressure values of the pre-charge gas predicted by a deep learning model. Further, the gas leakage determining device 102 may determine gas leakage in the accumulator based on the change in molar mass of the pre-charge gas and the information. For example, based on the information on pre-charge gas pressure, a molar mass of the pre-charge gas may be computed using the real gas equation.

20 [026] As will be described in greater detail in conjunction with FIGS. 2 – 7, the gas leakage determining device 102 may receive, from a plurality of sensors, one or more parameters of a pre-charge gas accommodated within the accumulator along with corresponding timeseries data indicating a time of detection of each of the one or more parameters. The gas leakage determining device 102 may further determine a change in molar mass of the pre-charge gas
25 based on the timeseries data using a physics-based model. The gas leakage determining device 102 may further determine an information associated with a pre-charge gas pressure based on the timeseries data using a deep learning model. The gas leakage determining device 102 may further predict a cause of failure of accumulator based on the determination of the change in the molar mass and the information.

30 [027] In some embodiments, the gas leakage determining device 102 may include one or more processors 104 and a computer-readable medium 106 (for example, a memory). Further, the computer-readable storage medium 106 may store instructions that, when executed by the one or more processors 104, may cause the one or more processors 104 to determine gas leakage in an accumulator, in accordance with aspects of the present disclosure. The computer-readable

storage medium 106 may also store various data (for example, one or more parameters, timeseries data corresponding to the one or more parameters, feature extraction data, deep learning model data, and the like) that may be captured, processed, and/or required by the system 100.

5 [028] The system 100 may further include a display 108. The system 100 may interact with a user via a user interface 110 accessible via the display 108. The system 100 may also include one or more external devices 112. In some embodiments, the gas leakage determining device 102 may interact with the one or more external devices 112 over a communication network 114 for sending or receiving various data. The external devices 112 may include, but may not
10 be limited to, a remote server, a digital device, or another computing system.

[029] Referring now to FIG. 2, a functional block diagram of a gas leakage determining device 200 (analogous to the gas leakage determining device 102) implemented by the exemplary system 100 is illustrated, in accordance with some embodiments. The gas leakage determining device 200 may include a physics-based model 202, a deep learning model 204, a cause of failure prediction module 206, a feature extraction model 208, and a cause of failure detection
15 module 210.

[030] The physics-based model 202 may receive input parameters 212 of a pre-charge gas accommodated within the accumulator along with corresponding timeseries data 214 indicating a time of detection of each of the input parameters 212 from a plurality of sensors (for example,
20 a pressure sensor, a temperature sensor, etc.). It should be noted that the timeseries data 214 corresponding to the input parameters 212 may be obtained using a Machine Learning (ML) model for failure prediction. The physics-based model 202 may generate an analytical model-based pressure and temperature profile and then compare the pressure and temperature profile with a measured pressure and temperature profile. Based on the comparison, the physics-based
25 model 202 may estimate or optimize number of moles to get an exact profile as the measured pressure and temperature profile. It may be noted that the physics-based model 202 may be based on thermodynamics and heat transfer equations. As will be appreciated, gas bladder accumulator may be modelled using ideal gas law equation (suitable only for high temperature and low pressure processes) or using real gas equations (such as, van der Waal's (vdW)
30 equation, Benedict Webb Rubin (BWR) equation, or Soave-Redlich-Kwong (SRK) equation). As will also be appreciated, the BWR equation is most used among the real gas equations.

[031] Further, the physics-based model 202 may determine a change in molar mass of the pre-charge gas based on the timeseries data 214. By way of an example, the physics-based model 202 may be a profile comparator-based model. The profile comparator-based model may be

created using at least one of analytical equations and simulation modelling tools for determining the change in molar mass of the pre-charge gas. When the profile comparator-based model is created using analytical equations, the change in molar mass of the pre-charge gas is determined by predicting one or more current parameters based on current timeseries data using the analytical equations, comparing each of the one or more current parameters with the corresponding one or more parameters, and identifying the change in molar mass of the pre-charge gas based on the comparison. Further, the physics-based model 202 may send the determined change in molar mass to the cause of failure prediction module 206.

[032] The deep learning model 204 may receive the timeseries data 214 from the plurality of sensors. Further, the deep learning model 204 may determine an information associated with a pre-charge gas pressure based on the timeseries data 214. Pre-charge pressure is defined as the pressure of the gas introduced in the accumulator when no fluid is present (i.e. gas volume is equal to the total volume of the accumulator). In an embodiment, the deep learning model 204 may employ a NonLinear AutoRegressive network with eXogenous (NARX) Neural Network (NN) architecture for determining the information. The deep learning model 204 can be used to identify useful features from the labeled state timeseries data 214. Possibility of in-operation learning can also be explored. In some embodiments, Python Keras, SK-Learn, and MXNet libraries can be utilized. Available test data size may be a major question for training. By way of an example, the test data may include 5 different pre-charge and 400 training cycles per pre-charge may be used. In another example, the test data may include 1 pre-charge and up to 2 hours of training cycles.

[033] Further, the deep learning model 204 may send the information to the cause of failure prediction module 206. The cause of failure prediction module 206 may predict a cause of failure (e.g., gas leakage) of the accumulator as output data 216 based on the determination of the change in the molar mass and the information.

[034] The feature extraction model 208 may receive the input parameters 212 from the plurality of sensors. Further, the feature extraction model 208 may evaluate and determine, from the one or more parameters, at least one coefficient of accumulator. It should be noted that the feature extraction model 208 may be created using Multiresolution Signal Decomposition (MSD). The feature extraction module 208 may evaluate useful state profile features and determine which features may represent or change largely with gas mass. In an embodiment, the determination of features may be manually performed. Further, the feature extraction model 208 may send the coefficient of accumulator to the cause of failure detection module 210.

[035] The cause of failure detection module 210 may detect the cause of failure (e.g., broken bladder) of the accumulator as output data 216 based on the evaluated at least one coefficient of accumulator. In an embodiment, the outcomes from each of the physics-based model 202, the feature extraction model 208, and the deep learning model 204 may be merged in Python to increase confidence on the output data 216. In such an embodiment, the physics-based model 202 may be used to precisely calculate current gas quantity inside the accumulator at any time and the deep learning model 204 may be used to predict a critically low pre-charge and detect a broken bladder with high level of confidence.

[036] It should be noted that all such a forementioned modules 202 – 210 may be represented as a single module or a combination of different modules. Further, as will be appreciated by those skilled in the art, each of the modules 202 – 210 may reside, in whole or in parts, on one device or multiple devices in communication with each other. In some embodiments, each of the modules 202 – 210 may be implemented as dedicated hardware circuit comprising custom application-specific integrated circuit (ASIC) or gate arrays, off-the-shelf semiconductors such as logic chips, transistors, or other discrete components. Each of the modules 202 – 210 may also be implemented in a programmable hardware device such as a field programmable gate array (FPGA), programmable array logic, programmable logic device, and so forth. Alternatively, each of the modules 202 – 210 may be implemented in software for execution by various types of processors (e.g., processor 104). An identified module of executable code may, for instance, include one or more physical or logical blocks of computer instructions, which may, for instance, be organized as an object, procedure, function, or other construct. Nevertheless, the executables of an identified module or component need not be physically located together, but may include disparate instructions stored in different locations which, when joined logically together, include the module and achieve the stated purpose of the module. Indeed, a module of executable code could be a single instruction, or many instructions, and may even be distributed over several different code segments, among different applications, and across several memory devices.

[037] As will be appreciated by one skilled in the art, a variety of processes may be employed for determining gas leakage in an accumulator. For example, the exemplary system 100 and the associated gas leakage determining device 102 may determine gas leakage in an accumulator by the processes discussed herein. In particular, as will be appreciated by those of ordinary skill in the art, control logic and/or automated routines for performing the techniques and steps described herein may be implemented by the system 100 and the gas leakage determining device 102 either by hardware, software, or combinations of hardware and

software. For example, suitable code may be accessed and executed by the one or more processors on the system 100 to perform some or all of the techniques described herein. Similarly, application specific integrated circuits (ASICs) configured to perform some or all of the processes described herein may be included in the one or more processors on the system
5 100.

[038] Referring now to FIG. 3, a simulation model 300 of a system for determining gas leakage in a gas accumulator 302 is illustrated, in accordance with an embodiment. The system may correspond to the system 100. The gas accumulator 302 may include a bladder fixed within a chamber of the gas accumulator 302. The bladder may hold a pre-charge gas and may be made
10 of a flexible material like rubber. Further, pressurized liquid (such as water or oil) may enter and accumulate within the chamber, causing the bladder to compress. When the liquid is required by the system of the simulation model 300, the liquid may leave the chamber, causing the bladder to expand. As the volume of the pre-charge gas changes, the pressure of the pre-charge gas (and the pressure on the liquid) changes inversely. It may be noted that while the
15 simulation model 300 represents a bladder accumulator, the simulation model 300 may be configured to represent a piston accumulator or a membrane accumulator upon modifying the required chemical and physical properties in accordance with the material used to make the accumulator.

[039] The gas accumulator 302 may be connected to a plurality of sensors. Each of the plurality
20 of sensors may detect one or more parameters (such as the input parameters 212) of a pre-charge gas accommodated within the gas accumulator 302. In some embodiments, the plurality of sensors may also provide to the system, along with the one or more parameters, corresponding timeseries data (such as the timeseries data 214) indicating a time of detection of each of the one or more parameters. The one or more parameters may include pressure (P),
25 temperature (T), and volume (or flow rate (Q)) corresponding to the pre-charge gas. Upon receiving the one or more parameters and the corresponding timeseries data from the plurality of sensors, the system may perform various computations to detect the leakage of gas in the gas accumulator 302.

[040] The simulation model 300 may include a signal builder 304. The signal builder 304 may
30 generate a pressure signal P. Additionally, the signal builder 304 may generate an opening area signal OP. Further, the simulation model 300 may include a controlled pressure source 306. It should be noted that the controlled pressure source 306 may act as a pump in the simulation model 300. The controlled pressure source 306 may receive the pressure signal P from the signal builder 304. Further, the controlled pressure source 306 may extract a liquid (e.g., oil)

from a first reservoir 308 by applying a pressure equivalent to the pressure signal P. The liquid in the simulation model 300 is represented as flowing in a direction from A to B. Further, the simulation model 300 includes a check valve 310. The check valve 310 may receive the liquid from the controlled pressure source 306 and may ensure that the liquid does not flow back to the controlled pressure source 306. As will be appreciated, reverse flow of the liquid may damage the controlled pressure source 306.

[041] Further, the liquid flows to a local restriction 312 (for example an orifice). The local restriction 312 may be an opening with an area corresponding to the opening area signal OP. It should be noted that the local restriction 312 may act as a hydraulic cylinder in the simulation model 300. The local restriction 312 can be controllably opened and closed based on the opening area signal OP received from the signal builder 304 using a simulation converter 1.

[042] When the local restriction 312 is closed, the liquid flows to the gas accumulator 302 through a first volumetric flow rate sensor 314. The first volumetric flow rate sensor 314 may generate a signal QA corresponding to a flow rate of the liquid through the gas accumulator 302 using the simulation converter 1. The local restriction 312 may remain closed to allow the liquid to fill the gas accumulator 302. Once the gas accumulator 302 is filled, the local restriction may be opened to allow excess liquid to flow through a second volumetric flow rate sensor 316 into a second reservoir 318. The second volumetric flow rate sensor 316 may generate a signal QP corresponding to a flow rate of the liquid through the local restriction 312 using a simulation converter 2.

[043] In some embodiments, the liquid flow is a cyclic process. In such embodiments, the first reservoir 308 is the same as the second reservoir 318. Alternately, in such embodiments, the first reservoir 308 is fluidically connected to the second reservoir 318. In some other embodiments, the liquid may be fed to another system through the second reservoir 318.

[044] It may be noted that each of measured values (i.e., signals) may correspond to a scope of the simulation model 300. Flow rate of the liquid may correspond to scope 1 (i.e., the signal QA and the signal QP may correspond to the scope 1). The signals QA and QP are coupled together in the scope 1 due to a correlation in the said signals. When liquid is filling the bladder of the gas accumulator 302, the signal QA may be higher than the signal QP. Preferably, the signal QP may be zero or of a negligible value. Similarly, when the bladder is filled, the liquid may flow through the local restriction 312 and therefore, the signal QA may be zero or negligible compared to the signal QP. The pressure signal P may correspond to scope 2 and the opening area signal OP may correspond to scope 3.

[045] Referring now to FIG. 4, a simulation model 400 of a sub-system for determining gas leakage in the gas accumulator 302 is illustrated, in accordance with an embodiment. FIG. 4 is explained in conjunction with FIG. 3. The sub-system may be a part of the system illustrated in FIG. 3. It should be noted that the simulation model 400 may be a sub-model of the simulation model 300. The sub-system may simulate the environmental conditions of the gas accumulator 302. As mentioned before, real gas equation may be used to determine the molar mass of the pre-charge gas. It should be noted that the simulation model 400 links heat transfer with the real gas equation to simulate the gas accumulator 302. In most embodiments, the bladder of the gas accumulator 302 may be made of a rubber material. Due to compression of the pre-charge gas within the gas accumulator 302, heat may be generated. Therefore, heat transfer may take place through the rubber material. Direction of the heat transfer is shown in the simulation model 400 from A to B (i.e., from high temperature to low temperature).

[046] As the liquid flows into and out of the gas accumulator from the simulation model 300, heat may be generated by the pre-charge gas. Heat generated from the pre-charge gas may first transfer to the liquid. Further, the heat may transfer to the rubber material of the bladder by a first liquid to rubber convection 402. Further, by a first rubber conduction 404, heat may be transferred through the rubber material to inner surface of a wall of the chamber of the gas accumulator 302. This heat exchange is cyclical and when temperature of the wall is higher than temperature of the liquid, heat may transfer from the inner surface of the wall to the rubber through a second rubber conduction 406 and a second liquid to rubber convection 408. Further, a wall conduction 410 may transfer the heat to outer surface of the wall of the chamber. Further, heat exchange will take place between the wall and ambient temperature 412 (i.e., outer environment of the gas accumulator 302) through ambient convection 414 and ambient radiation 416.

[047] A plurality of sensors (such as a pressure sensor 418 and a temperature sensor 420) may be coupled to the gas accumulator 302. The pressure sensor 418 may detect a gas pressure signal PG corresponding to a pressure of the pre-charge gas in the bladder of the gas accumulator 302. The temperature sensor 420 may detect a temperature signal TG corresponding to a temperature of the pre-charge gas in the bladder of the gas accumulator 302. A reference G may be included in the simulation model 400 to automatically normalize the temperature.

[048] Referring now to FIG. 5, a simulation model of the gas accumulator 302 is illustrated, in accordance with an embodiment. FIG. 5 is explained in conjunction with FIGs. 3 and 4. The gas accumulator 302 may include a bladder within a chamber. The bladder may include the

pre-charge gas. Further, the chamber may receive an inflow of the liquid. The pressure and temperature of the pre-charge gas may be measured through the corresponding sensors 418 and 420, respectively, of the simulation model 400 (denoted in the simulation model 500 as parameter measurement flow A). The flow rate of the liquid may be measured using the signal
5 QA through the first volumetric flow sensor 314 (denoted in the simulation model 500 as parameter measurement flow A). Further, heat exchange of the gas and the liquid with the environment may be simulated as per the simulation model 400 (denoted in the simulation model 500 as heat flow H).

[049] The simulation model 500 simulates the gas accumulator 302 through a first cylinder 502
10 and a second cylinder 504. The first cylinder 502 simulates the pre-charge gas of the gas accumulator 302. The second cylinder 504 simulates the liquid of the gas accumulator 302. As explained previously, when the liquid flows into the gas accumulator 302, the bladder with the pre-charge gas compresses. Therefore, to replicate such a real scenario, when the liquid flows into the second cylinder 504, volume of the first cylinder 502 may reduce. Similarly, when the
15 liquid flows out of the second cylinder 504, volume of the first cylinder 502 may increase. This may be obtained by connecting the first cylinder 502 and the second cylinder 504 with a rod R. Parameters corresponding to the first cylinder 502 and the second cylinder 504 are denoted in the simulation model 500 as C.

[050] Further, the simulation model 500 may include a translational hard stop 506 to provide a
20 limit to the bladder (i.e., the first cylinder 502) of the gas accumulator 302 to replicate the real world scenario as the bladder cannot expand beyond the walls of the chamber of an accumulator. It should be noted that the first cylinder cannot expand beyond the translational hard stop 506. Further, the simulation model 500 includes a translational friction 508 to simulate a friction between the bladder (i.e., the first cylinder 502) and the wall of the gas accumulator 302.
25 Further, the simulation model 500 may include a gas translational mechanical converter 510 and a liquid translational mechanical converter 512 to simulate mechanical energy flow between the first cylinder 502 and the second cylinder 504.

[051] It should be noted that the simulation models 300, 400, and 500 are shown to simulate a
30 bladder accumulator. However, the simulation models 300, 400, and 500 can be configured to simulate any other accumulators (such as membrane accumulator or piston accumulator). For example, the simulation models 300, 400, and 500 can be configured to simulate a piston accumulator by replacing heat transfer properties of rubber material (used to make the bladder) with heat transfer properties of aluminum material (or any other material used to make the accumulator).

[052] Referring now to FIG. 6, training of a predictive model 602 for determining gas leakage in an accumulator is illustrated, in accordance with some embodiments. The predictive model 602 may be generated through a training module 604. The training module 604 may include a physics-based model 606, a manual feature extraction module 608, and a deep learning model 610. The training module 604 may receive training data 612. The training data 612 may include data corresponding to various parameters such as, but not limited to, measured gas pressure, measured gas temperature, test pre-charge pressure at 20 °C, flow rate in/out from accumulator, fluid pressure, ambient temperature, and the like.

[053] Further, the training module 604 may use the training data 612 to train each of the physics-based model 606, the manual feature extraction module 608, and the deep learning model 610. Upon training, the training module 604 may then deploy the predictive model 602. The predictive model 602 may receive real-time data 614 from the plurality of sensors and may use the real-time data 614 to determine computed data 616.

[054] Referring now to FIG. 7, an exemplary process 700 for determining gas leakage in an accumulator is depicted via a flowchart, in accordance with some embodiments. In an embodiment, the process 700 may be implemented by the gas leakage determining device 102 of the system 100. The process 700 may include receiving, from a plurality of sensors, one or more parameters of a pre-charge gas accommodated within the accumulator along with corresponding timeseries data indicating a time of detection of each of the one or more parameters, at step 702. The one or more parameters may be received by each of the physics-based model 202 and the feature extraction model 208 and the timeseries data may be received by each of the physics-based model 202 and the deep learning model 204.

[055] Further, the process 700 may include determining a change in molar mass of the pre-charge gas based on the timeseries data using a physics-based model (for example, the physics-based model 202), at step 704. The step 704 of the process 700 may include predicting one or more current parameters based on current timeseries data using the analytical equations, at step 706. Further, the step 704 of the process 700 may include comparing each of the one or more current parameters with the corresponding one or more parameters, at step 708. Further, the step 704 of the process 700 may include identifying the change in molar mass of the pre-charge gas based on the comparison, at step 710.

[056] Further, the process 700 may include determining an information associated with a pre-charge gas pressure based on the timeseries data using a deep learning model (for example, the deep learning model 204), at step 712. In an embodiment, the deep learning model may employ an NARX NN architecture for determining the information. Further, the process 700 may

include predicting, by the cause of failure prediction module 206, a cause of failure of accumulator based on the determination of the change in the molar mass and the information, at step 714.

5 [057] Further, the process 700 may include evaluating from the one or more parameters, at least one coefficient of accumulator, at step 716. The coefficient of accumulator is determined using a feature extraction model (for example, the feature extraction model 208). The feature extraction model may be created using MSD. Further, the process 700 may include detecting, by the cause of failure detection module 210, the cause of failure of the accumulator based on the evaluated at least one coefficient of accumulator, at step 718.

10 [058] Referring now to FIG. 8, a detailed exemplary process 800 of implementing a model-based profile comparator is depicted via a flow chart, in accordance with some embodiments. In an embodiment, the model-based profile comparator is based on a physics-based model (for example, the physics-based model 202). The model-based profile comparator may be created using 2 approaches, i.e., using partial differential equations (PDEs) and using modelling tools.

15 The process 800 may include creating an accumulator model (i.e., a digital twin), at step 802. This may involve a detailed physical modelling of accumulator system. The accumulator model may be analogous to the physics-based model 202 and may be represented by equation (1):

[059] $[P(t), T(t)] = \text{Fun}(\text{nmol}, Q(t))$
(1)

20 [060] Where, P corresponds to pressure of the gas,

[061] T corresponds to temperature of the gas,

[062] nmol corresponds to number of moles of the gas, and

[063] Q corresponds to the flow rate of the gas.

[064] Further, the process 800 may include recording accumulator states, at step 804. The
25 accumulator states may include gas pressure, gas temperature, and ambient temperature. Therefore, in accordance with the equation (1), the physics-based model 202 may receive pressure and temperature information as an input from the plurality of sensors. Further, the process 800 may include approximating flowrate based on measured states, at step 806.

[065] Further, the process 800 may include optimizing profile based on different function
30 inputs, at step 808. The model may be tuned to match current output during operation. Tuning may be represented by equation (2):

[066] $[P1(t), P2(t), \dots, T1(t), T2(t), \dots] = \text{Fun}(Q1(t), Q2(t), \dots, \text{nmol1}, \text{nmol2}, \dots)$
(2)

[067] This may be accomplished through the timeseries data corresponding to the pressure and temperature values measured by the plurality of sensors at each time instance. Further, the process 800 may include comparing closest matched profile, at step 810. Further, the process 800 may include outputting number of moles (i.e., nmol), at step 812.

5 [068] Referring now to FIG. 9, a detailed exemplary control logic 900 for implementing a model-based profile comparator in run-time is depicted via a flow chart, in accordance with some embodiments. In an embodiment, the model-based profile comparator is based on a physics-based model (for example, the physics-based model 202). The model-based profile comparator may be created using 2 approaches, i.e., using PDEs and using modelling tools.

10 Modelling approach using PDEs includes modelling gas chamber of the accumulator. A Heat Transfer Model of the accumulator with an equivalent thermal time constant (τ) may be created. It should be noted that the thermal time constant directly depends on mass of the gas.

[069] Thus, Equation of State (EOS) for real gas (vdW, Bridgeman, BWR, SRK) calculated using heat transfer and first law of thermodynamics is represented by equation (3):

15 [070]
$$\frac{\tau dT}{dt} + T = T_w - \frac{T\tau}{c_v} \left(\frac{\partial P}{\partial T} \right)_v \frac{dv}{dt}$$

(3)

[071] Where τ is thermal time constant and is represented through equation (4):

[072]
$$\tau = \frac{m_g c_v}{hA}$$
 (4)

[073] Note: here h represents overall heat transfer coefficient of the accumulator.)

20 [074] It may be noted that for piston type accumulator, the equation (4) can be approximated to equation (5):

[075]
$$\tau \approx 0.3pv^{0.33} + 86.2v^{0.49}$$

(5)

[076] A temperature sensor having second order lag may be modelled using the PDE approach.

25 Further, model parameters may be specified and tuned. The model parameters may include heat transfer coefficients of shell and bladder, effective area for heat transfer, sensor time constant, nominal value of fluid temperature, accumulator volume (V0), and the like.

[077] Once the physics-based model has been created, tuned, and validated with experimental data, the control logic 900 may include, based on a sensor input 902, estimating current volume profile using old nmol data and sensor data by the physics-based model 202, at step 904. In an embodiment, the physics-based model may be generated and tuned by the process 800.

30

[078] Further, at step 906 of the control logic 900, a check may be performed to determine whether the estimated current volume profile matches with the sensor input 902. If the

estimated current volume profile does not match with the sensor input 902, the control logic 900 may include updating nmol data, at step 908. The updated nmol data is then sent to the model to estimate the current volume profile using the updated nmol data. If the estimated current volume profile matches with the sensor input 902, the control logic 900 may include outputting the nmol data, at step 910.

[079] Referring now to FIG. 10, a simulation model 1000 of a model-based profile comparator, in accordance with an embodiment. The simulation model 1000 includes a gas accumulator (such as the gas accumulator 302) connected to a plurality of sensors. The simulation model 1000 includes a first cylinder 1002 and a second cylinder 1004 mechanically connected with each other through a rod R. The first cylinder 1002 may include the pre-charge gas (simulating a bladder of the gas accumulator 302) and the second cylinder 1004 may include the liquid (simulating a chamber of the gas accumulator 302). It should be noted that the simulation model 1000 may simulate parameter measurement (denoted as parameter measurement flow A) of the pre-charge gas, heat exchange of the pre-charge gas with the environment (denoted as heat flow H), and flow input 1006 of the liquid (denoted as flow S) into the second cylinder 1004 through a multiplier K for scaling the flow input. The parameter measurement flow A may generate a pressure signal P and a temperature signal T corresponding to the pre-charge gas.

[080] The model-based profile comparator may use measured values of the pre-charge gas temperature, pre-charge gas pressure, and liquid flow rate from the simulation model 1000 to determine nmol parameter (i.e., number of moles corresponding to the molar mass of the pre-charge gas). Further, each of the measured values may be compared with a corresponding detected value of a real gas accumulator to validate the simulation model 1000 and to detect a gas leakage in the real gas accumulator.

[081] It should be noted that when creating the model-based profile comparator using modelling tools, existing physical system modelling tools (for example, Simscape®) may be used. Such a modelling approach has two major advantages: (a) a validated gas model is already used in simulation tools, and (b) integrator (solver) is not required to be created. However, a drawback of using modelling tools for creating the profile comparator is that C-code of model can be generated along with solver, but generated code will be impossible to modify afterwards. Additionally, if remodeling task is required, (such as, changing parameters, accumulator capacity (V0), convective heat transfer coefficient, or changing model complexity), in such cases, the model needs to be rebuilt and the C/C++ code needs to be regenerated.

[082] Referring now to FIG. 11, a detailed exemplary process 1100 of feature extraction using ML is depicted via a flow chart, in accordance with some embodiments. In an embodiment, the

process 1100 may be implemented by the feature extraction model 208 of the system 200. This approach involves evaluating useful state profile features and deciding (manually) which features may represent or change largely with gas mass. Example of state profile features may include, but may not be limited to, nth derivatives of pressure and temperature values, slope of temperature profile after reaching peak value, wavelet decomposed coefficients of profiles, or standard wave characteristics (such as median, variance, skewness, kurtosis, etc.). The features may then be fed as training data to ML algorithms.

[083] The process 1100 may include pressure/temperature signal decomposition, at step 1102. As will be appreciated by those skilled in the art, gas leakage creates increased variations in pressure signal and would amplify load flow variations in supply pressure. The pressure/temperature signal decomposition may be performed via MSD. MSD based on wavelets is used to extract the features from measured pressure signal. Discrete decomposition of the signals with Quadrature Mirror Filters (QMF) based on high and low pass filters may give detail ($d_j(k)$) and approximate ($a_l(k)$) coefficients. d_j shows increased variations in the amplitude with decrease in ppc. RMS of the coefficient is used for the comparative measure of fault detection. RMS value of level 9 and 10 shows more sensitivity to fault for $ppc < 130 \text{ bar}$. T_a causes more disturbance to increase the robustness the operating ambient temperature is 22-60°C. The effect of external fluid leakage seems to be insignificant.

[084] Further, the process 1100 may include identifying indicators sensitive to gas leakage, at step 1104. Sensitive features (e.g., coefficients) may be identified for ML models. Further, the process 1100 may include training ML models, at step 1106. The ML models may be based on one or more of nearest neighbours algorithm, naive Bayes algorithm, and Support Vector Machine (SVM) algorithm. A Learned function may be obtained upon training the ML modes. Further, the process 1100 may include deploying trained algorithm, at step 1108.

[085] It may be noted that a limitation of physics-based model is that size of algorithm and execution may not be appropriate for on-board processing. A limitation of manual feature extraction using ML is that wavelet transform-based studies have been done for a specific application. In the present disclosure, it is applied to estimate accumulator pre-charge pressure used in wind turbines. Thus, this approach may work only for application for which it has been trained or analyzed. A limitation of deep learning model is that data may be available only for one accumulator volume (v_0). Trained NN may only work for that specific volume of the accumulator. However, by using these three approaches in a combination, the gas leakage device 102 overcomes the aforementioned limitations and minimizes the scope for error.

[086] Referring now to FIG. 12, a set of graphs representing flow rate and pressure comparison of a model-based accumulator (such as the gas accumulator 302) with a real accumulator is illustrated, in accordance with an embodiment. For a first scenario (based on data collected at time t1) from a simulation model of the gas accumulator (such as the simulation model 300), the set of graphs includes a volumetric flow rate vs time graph 1200a and a corresponding pressure vs time graph 1200b. For a second scenario (based on data collected at time t1) from a real gas accumulator from a pressure sensor and a volumetric flow rate sensor, the set of graphs includes a volumetric flow rate vs time graph 1200c and a corresponding pressure vs time graph 1200d.

[087] It should be noted that for the volumetric flow rate vs time graphs 1200a and 1200c, the volumetric flow rate values are represented in m^3s^{-1} and the time values are represented in seconds (s). Further, each of the volumetric flow rate vs time graphs 1200a and 1200c represent a volumetric flow rate Q_A of the liquid through the accumulator and a volumetric flow rate Q_P of the liquid through a local restriction. It should also be noted that for the pressure vs time graphs 1200b and 1200d, the pressure values are represented in Pascals (Pa) and the time values are represented in seconds (s). A comparison between the flow rate vs time graphs 1200a and 1200c indicates that the flow rates of the liquid through the model-based accumulator and the local restriction in the model-based accumulator is approximately equal to the flow rates of the liquid through the real accumulator and the local restriction in the real accumulator. On the other hand, a comparison between the pressure vs time graphs 1200b and 1200d indicates a clear reduction in the pressure of the pre-charge gas in the real accumulator as compared to the pressure of the pre-charge gas in the model-based accumulator. Based on the two comparisons, it may be inferred that there is a leakage of pre-charge gas in the real accumulator.

[088] Referring now to FIG. 13, a set of graphs representing MSD coefficients at various levels is illustrated, in accordance with an embodiment. Graph 1300a represents values corresponding to approximation coefficients. Graph 1300b represents values corresponding to a detail coefficient of level 1. Graph 1300c represents values corresponding to a detail coefficient of level 2. Graph 1300d represents values corresponding to a detail coefficient of level 3. Graph 1300e represents values corresponding to a detail coefficient of level 4. Graph 1300f represents values corresponding to a detail coefficient of level 5. Graph 1300g represents values corresponding to a Root Mean Square (RMS) of the detail coefficient of levels 1, 2, 3, 4, and 5.

[089] As will be appreciated, pressure signal received from the accumulator includes leakage data embedded on it and is used as an input. However, to analyze the pressure signal, MSD

technique is implemented to decompose the raw pressure signal (i.e., wavelet in original form). The detailed coefficients may facilitate decomposition of the wavelet. It should be noted that RMS value increases with decrease in pre-charge pressure which corresponds to leakage of gas. Therefore, leakage or fault detection corresponding to the accumulator may be performed through the MSD technique.

5 [090] Referring now to FIG. 14, a graph 1400 representing prediction of volume of gas in an accumulator using a deep learning model (such as the deep learning model 204) is illustrated, in accordance with an embodiment. The graph 1400 is a volume vs time graph representing values corresponding to a predicted volume (i.e., volume of the pre-charge gas as predicted by the deep learning model) and an actual volume (i.e., volume of the pre-charge gas as detected by the plurality of sensors). Based on the graph 1400, it may be inferred that the deep learning model predicts the volume of gas accurately and provides a 1-step ahead prediction for the volume of the pre-charge gas.

10 [091] As will be also appreciated, the above described techniques may take the form of computer or controller implemented processes and apparatuses for practicing those processes. The disclosure can also be embodied in the form of computer program code containing instructions embodied in tangible media, such as floppy diskettes, solid state drives, CD-ROMs, hard drives, or any other computer-readable storage medium, wherein, when the computer program code is loaded into and executed by a computer or controller, the computer becomes an apparatus for practicing the invention. The disclosure may also be embodied in the form of computer program code or signal, for example, whether stored in a storage medium, loaded into and/or executed by a computer or controller, or transmitted over some transmission medium, such as over electrical wiring or cabling, through fiber optics, or via electromagnetic radiation, wherein, when the computer program code is loaded into and executed by a computer, the computer becomes an apparatus for practicing the invention. When implemented on a general-purpose microprocessor, the computer program code segments configure the microprocessor to create specific logic circuits.

15 [092] The disclosed methods and systems may be implemented on a conventional or a general-purpose computer system, such as a personal computer (PC) or server computer. Referring now to FIG. 15, an exemplary computing system 1500 that may be employed to implement processing functionality for various embodiments (e.g., as a SIMD device, client device, server device, one or more processors, or the like) is illustrated. Those skilled in the relevant art will also recognize how to implement the invention using other computer systems or architectures. The computing system 1500 may represent, for example, a user device such as a desktop, a

laptop, a mobile phone, personal entertainment device, DVR, and so on, or any other type of special or general-purpose computing device as may be desirable or appropriate for a given application or environment. The computing system 1500 may include one or more processors, such as a processor 1502 that may be implemented using a general or special purpose processing engine such as, for example, a microprocessor, microcontroller or other control logic. In this example, the processor 1502 is connected to a bus 1504 or other communication medium. In some embodiments, the processor 1502 may be an Artificial Intelligence (AI) processor, which may be implemented as a Tensor Processing Unit (TPU), or a graphical processor unit, or a custom programmable solution Field-Programmable Gate Array (FPGA).

5 [093] The computing system 1500 may also include a memory 1506 (main memory), for example, Random Access Memory (RAM) or other dynamic memory, for storing information and instructions to be executed by the processor 1502. The memory 1506 also may be used for storing temporary variables or other intermediate information during execution of instructions to be executed by the processor 1502. The computing system 1500 may likewise include a read

10 only memory (“ROM”) or other static storage device coupled to bus 1504 for storing static information and instructions for the processor 1502.

[094] The computing system 1500 may also include a storage devices 1508, which may include, for example, a media drive 1510 and a removable storage interface. The media drive 1510 may include a drive or other mechanism to support fixed or removable storage media,

20 such as a hard disk drive, a floppy disk drive, a magnetic tape drive, an SD card port, a USB port, a micro USB, an optical disk drive, a CD or DVD drive (R or RW), or other removable or fixed media drive. A storage media 1512 may include, for example, a hard disk, magnetic tape, flash drive, or other fixed or removable medium that is read by and written to by the media drive 1510. As these examples illustrate, the storage media 1512 may include a

25 computer-readable storage medium having stored therein particular computer software or data.

[095] In alternative embodiments, the storage devices 1508 may include other similar instrumentalities for allowing computer programs or other instructions or data to be loaded into the computing system 1500. Such instrumentalities may include, for example, a removable storage unit 1514 and a storage unit interface 1516, such as a program cartridge and cartridge

30 interface, a removable memory (for example, a flash memory or other removable memory module) and memory slot, and other removable storage units and interfaces that allow software and data to be transferred from the removable storage unit 1514 to the computing system 1500.

[096] The computing system 1500 may also include a communications interface 1518. The communications interface 1518 may be used to allow software and data to be transferred

between the computing system 1500 and external devices. Examples of the communications interface 1518 may include a network interface (such as an Ethernet or other NIC card), a communications port (such as for example, a USB port, a micro USB port), Near field Communication (NFC), etc. Software and data transferred via the communications interface 1518 are in the form of signals which may be electronic, electromagnetic, optical, or other signals capable of being received by the communications interface 1518. These signals are provided to the communications interface 1518 via a channel 1520. The channel 1520 may carry signals and may be implemented using a wireless medium, wire or cable, fiber optics, or other communications medium. Some examples of the channel 1520 may include a phone line, a cellular phone link, an RF link, a Bluetooth link, a network interface, a local or wide area network, and other communications channels.

[097] The computing system 1500 may further include Input/Output (I/O) devices 1522. Examples may include, but are not limited to a display, keypad, microphone, audio speakers, vibrating motor, LED lights, etc. The I/O devices 1522 may receive input from a user and also display an output of the computation performed by the processor 1502. In this document, the terms “computer program product” and “computer-readable medium” may be used generally to refer to media such as, for example, the memory 1506, the storage devices 1508, the removable storage unit 1514, or signal(s) on the channel 1520. These and other forms of computer-readable media may be involved in providing one or more sequences of one or more instructions to the processor 1502 for execution. Such instructions, generally referred to as “computer program code” (which may be grouped in the form of computer programs or other groupings), when executed, enable the computing system 1500 to perform features or functions of embodiments of the present invention.

[098] In an embodiment where the elements are implemented using software, the software may be stored in a computer-readable medium and loaded into the computing system 1500 using, for example, the removable storage unit 1514, the media drive 1510 or the communications interface 1518. The control logic (in this example, software instructions or computer program code), when executed by the processor 1502, causes the processor 1502 to perform the functions of the invention as described herein.

[099] Thus, the disclosed method and system try to overcome the technical problem of determining gas leakage in an accumulator. The method and system provide hydraulic system intelligence that enhances safety and productivity, and optimizes cost of operation through better machine control. Further, the method and system implement diagnostics of the accumulator system through enhancement of the sensor integration and provide real-time data

on hydraulics performance metrics. Increasing intelligence of hydraulic accumulator systems is driven by distributed intelligence enabled by low-cost computing and sensor technology, and by effective transmission of data with improved cellular infrastructure.

5 [0100] As will be appreciated by those skilled in the art, the techniques described in the various embodiments discussed above are not routine, or conventional, or well understood in the art. The techniques discussed above provide for determining gas leakage in an accumulator. The techniques may first receive, from a plurality of sensors, one or more parameters of a pre-charge gas accommodated within the accumulator along with corresponding timeseries data indicating a time of detection of each of the one or more parameters. The techniques may then
10 determine a change in molar mass of the pre-charge gas based on the timeseries data using a physics-based model. The techniques may then determine an information associated with a pre-charge gas pressure based on the timeseries data using a deep learning model. The techniques may then predict a cause of failure of the accumulator based on the determination of the change in the molar mass and the information.

15 [0101] In light of the above mentioned advantages and the technical advancements provided by the disclosed method and system, the claimed steps as discussed above are not routine, conventional, or well understood in the art, as the claimed steps enable the following solutions to the existing problems in conventional technologies. Further, the claimed steps clearly bring an improvement in the functioning of the device itself as the claimed steps provide a technical
20 solution to a technical problem.

[0102] The specification has described method and system for determining gas leakage in an accumulator. The illustrated steps are set out to explain the exemplary embodiments shown, and it should be anticipated that ongoing technological development will change the manner in which particular functions are performed. These examples are presented herein for purposes of
25 illustration, and not limitation. Further, the boundaries of the functional building blocks have been arbitrarily defined herein for the convenience of the description. Alternative boundaries can be defined so long as the specified functions and relationships thereof are appropriately performed. Alternatives (including equivalents, extensions, variations, deviations, etc., of those described herein) will be apparent to persons skilled in the relevant art(s) based on the teachings
30 contained herein. Such alternatives fall within the scope and spirit of the disclosed embodiments.

[0103] Furthermore, one or more computer-readable storage media may be utilized in implementing embodiments consistent with the present disclosure. A computer-readable storage medium refers to any type of physical memory on which information or data readable

by a processor may be stored. Thus, a computer-readable storage medium may store instructions for execution by one or more processors, including instructions for causing the processor(s) to perform steps or stages consistent with the embodiments described herein. The term “computer-readable medium” should be understood to include tangible items and exclude carrier waves and transient signals, i.e., be non-transitory. Examples include random access memory (RAM), read-only memory (ROM), volatile memory, nonvolatile memory, hard drives, CD ROMs, DVDs, flash drives, disks, and any other known physical storage media.

[0104] It is intended that the disclosure and examples be considered as exemplary only, with a true scope and spirit of disclosed embodiments being indicated by the following claims.

WE CLAIM:

1. A method (700) for determining gas leakage in an accumulator, the method (700) comprising:

receiving (702), by a gas leakage determining device (102) and from a plurality of sensors, one or more parameters of a pre-charge gas accommodated within the accumulator along with corresponding timeseries data (214) indicating a time of detection of each of the one or more parameters;

determining (704), by the gas leakage determining device (102), a change in molar mass of the pre-charge gas based on the timeseries data (214) using a physics-based model (202);

determining (712), by the gas leakage determining device (102), an information associated with a pre-charge gas pressure based on the timeseries data (214) using a deep learning model (204); and

predicting (714), by the gas leakage determining device (102), a cause of failure of the accumulator based on the determination of the change in the molar mass and the information.

2. The method (700) as claimed in claim 1, wherein the physics-based model (202) is a profile comparator-based model, and wherein the profile comparator-based model is created using at least one of analytical equations and simulation modelling tools for determining the change in molar mass of the pre-charge gas.

3. The method (700) as claimed in claim 2, wherein determining (704) the change in molar mass of the pre-charge gas based on the analytical equations comprises:

predicting (706) one or more current parameters based on current timeseries data (214) using the analytical equations;

comparing (708) each of the one or more current parameters with the corresponding one or more parameters; and

identifying (710) the change in molar mass of the pre-charge gas based on the comparison.

4. The method (700) as claimed in claim 1, further comprising:

evaluating (716) from the one or more parameters, at least one coefficient of accumulator, wherein the coefficient of accumulator is determined using a feature extraction model (208), and wherein the feature extraction model (208) is created using Multiresolution Signal Decomposition (MSD); and

detecting (718) the cause of failure of the accumulator based on the evaluated at least one coefficient of accumulator.

5. The method (700) as claimed in claim 1, wherein the deep learning model (204) employs a NonLinear AutoRegressive network with eXogenous (NARX) neural network architecture for determining the information.

6. The method (700) as claimed in claim 1, further comprising obtaining the timeseries data (214) corresponding to the one or more parameters using a Machine Learning (ML) model.

7. A system (100) for determining gas leakage in an accumulator, the system (100) comprising:
a processor (104); and
a memory communicatively coupled to the processor (104), wherein the memory stores processor instructions, which when executed by the processor (104), cause the processor (104) to:

receive (702), from a plurality of sensors, one or more parameters of a pre-charge gas accommodated within the accumulator along with corresponding timeseries data (214) indicating a time of detection of each of the one or more parameters;

determine (704) a change in molar mass of the pre-charge gas based on the timeseries data (214) using a physics-based model (202);

determine (712) an information associated with a pre-charge gas pressure based on the timeseries data (214) using a deep learning model (204); and

predict (714) a cause of failure of the accumulator based on the determination of the change in the molar mass and the information.

8. The system (100) as claimed in claim 7, wherein the physics-based model (202) is a profile comparator-based model, and wherein the profile comparator-based model is created using at least one of analytical equations and simulation modelling tools for determining the change in molar mass of the pre-charge gas.

9. The system (100) as claimed in claim 8, wherein to determine (704) the change in molar mass of the pre-charge gas based on the analytical equations, the processor instructions, on execution, cause the processor (104) to:

predict (706) one or more current parameters based on current timeseries data (214) using the analytical equations;

compare (708) each of the one or more current parameters with the corresponding one or more parameters; and

identify (710) the change in molar mass of the pre-charge gas based on the comparison.

10. The system (100) as claimed in claim 7, wherein the processor instructions, on execution, further cause the processor (104) to:

evaluate (716) from the one or more parameters, at least one coefficient of accumulator, wherein the coefficient of accumulator is determined using a feature extraction model (208), and wherein the feature extraction model (208) is created using Multiresolution Signal Decomposition (MSD); and

detect (718) the cause of failure of the accumulator based on the evaluated at least one coefficient of accumulator.

Dated this 17th day of March 2023

-- Digitally Signed--

Bhanu Prasad
(INPA No: **3253**)
Head, IPR Dept.,
L&T Technology Services Limited,
DLF 3rd Block, 2nd Floor,
Manapakkam, Chennai - 600089.

ABSTRACT

METHOD AND SYSTEM FOR DETERMINING GAS LEAKAGE IN AN ACCUMULATOR

This disclosure relates to method (700) and system (100) for determining gas leakage in an accumulator. The method includes receiving (702), from a plurality of sensors, one or more parameters of a pre-charge gas accommodated within the accumulator along with corresponding timeseries data (214) indicating a time of detection of each of the one or more parameters. The method (700) further includes determining (704) a change in molar mass of the pre-charge gas based on the timeseries data (214) using a physics-based model (202). The method (700) further includes determining (712) an information associated with a pre-charge gas pressure based on the timeseries data (214) using a deep learning model (204). The method further (700) includes predicting (714) a cause of failure of the accumulator based on the determination of the change in the molar mass and the information.

[To be published with Figure 2]

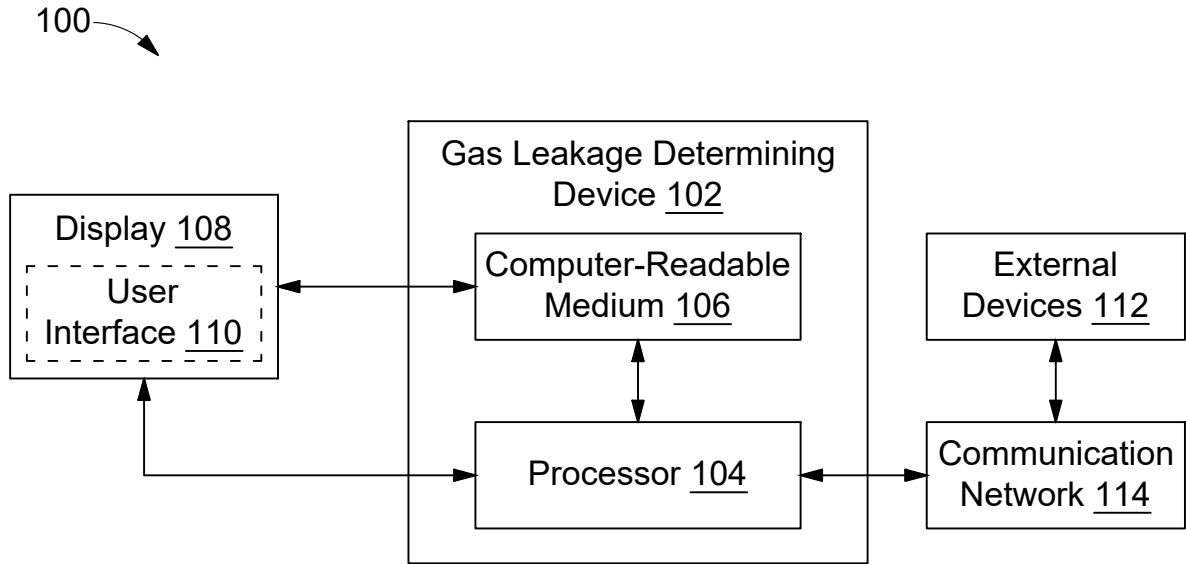

FIG. 1

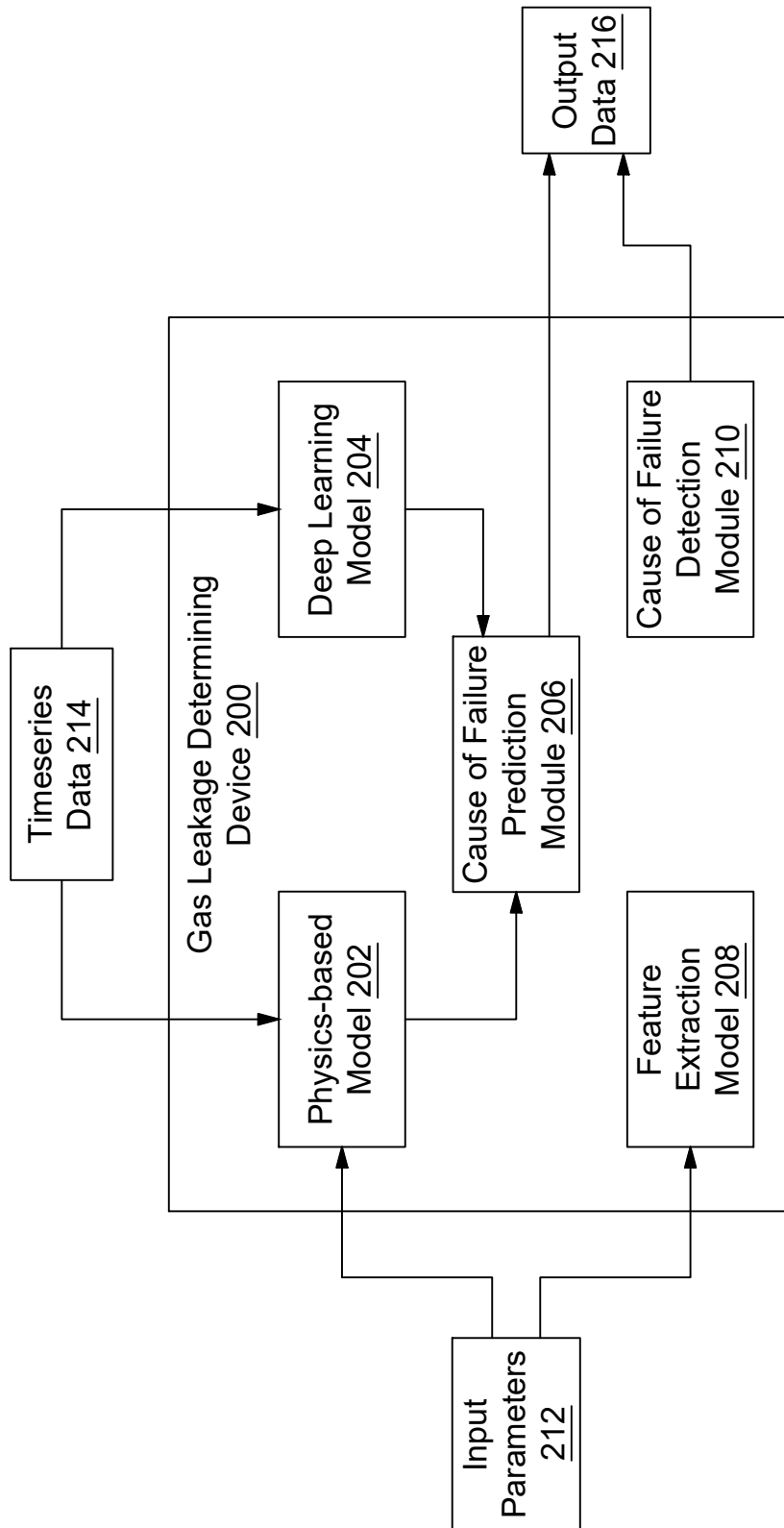

FIG. 2

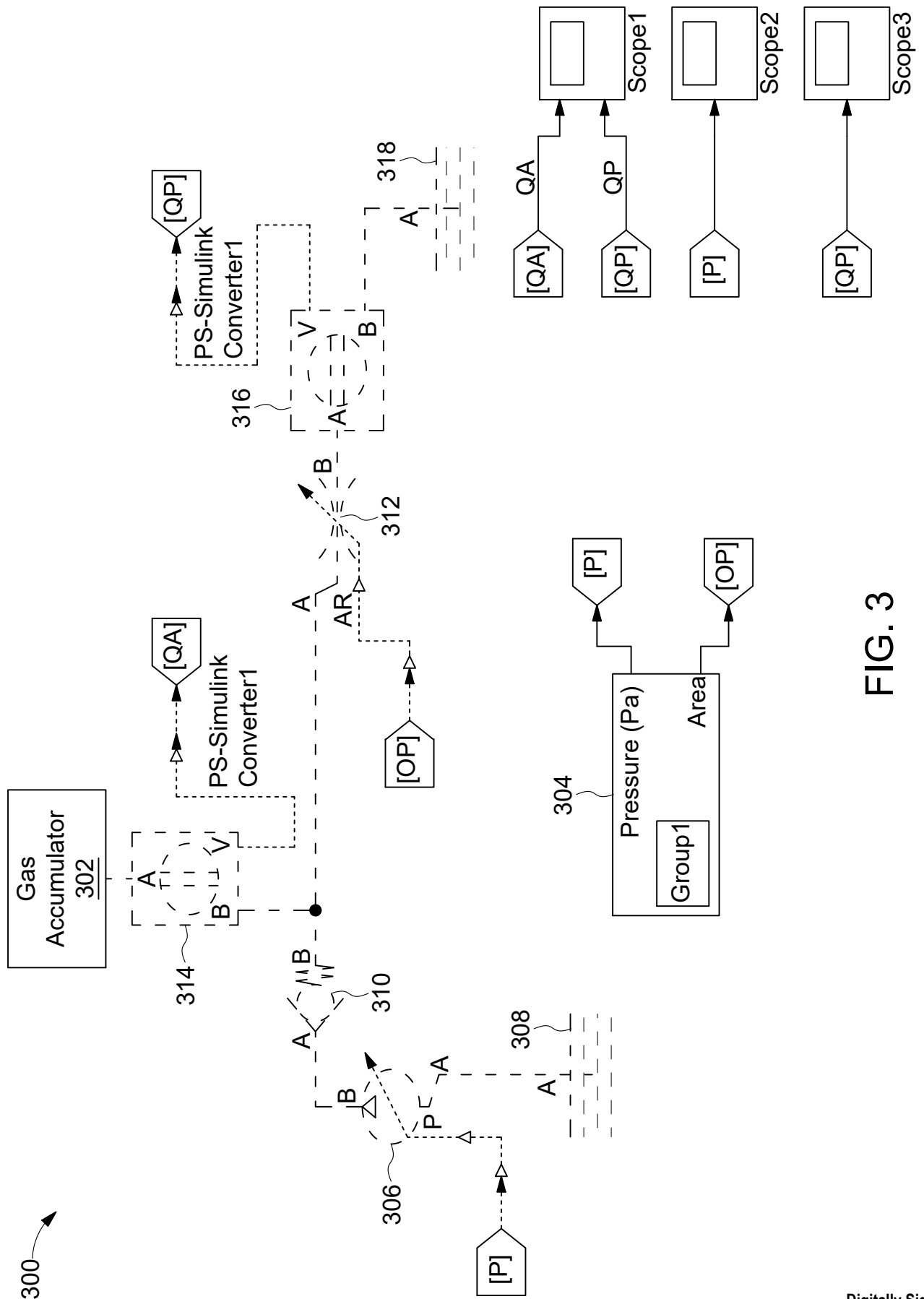

FIG. 3

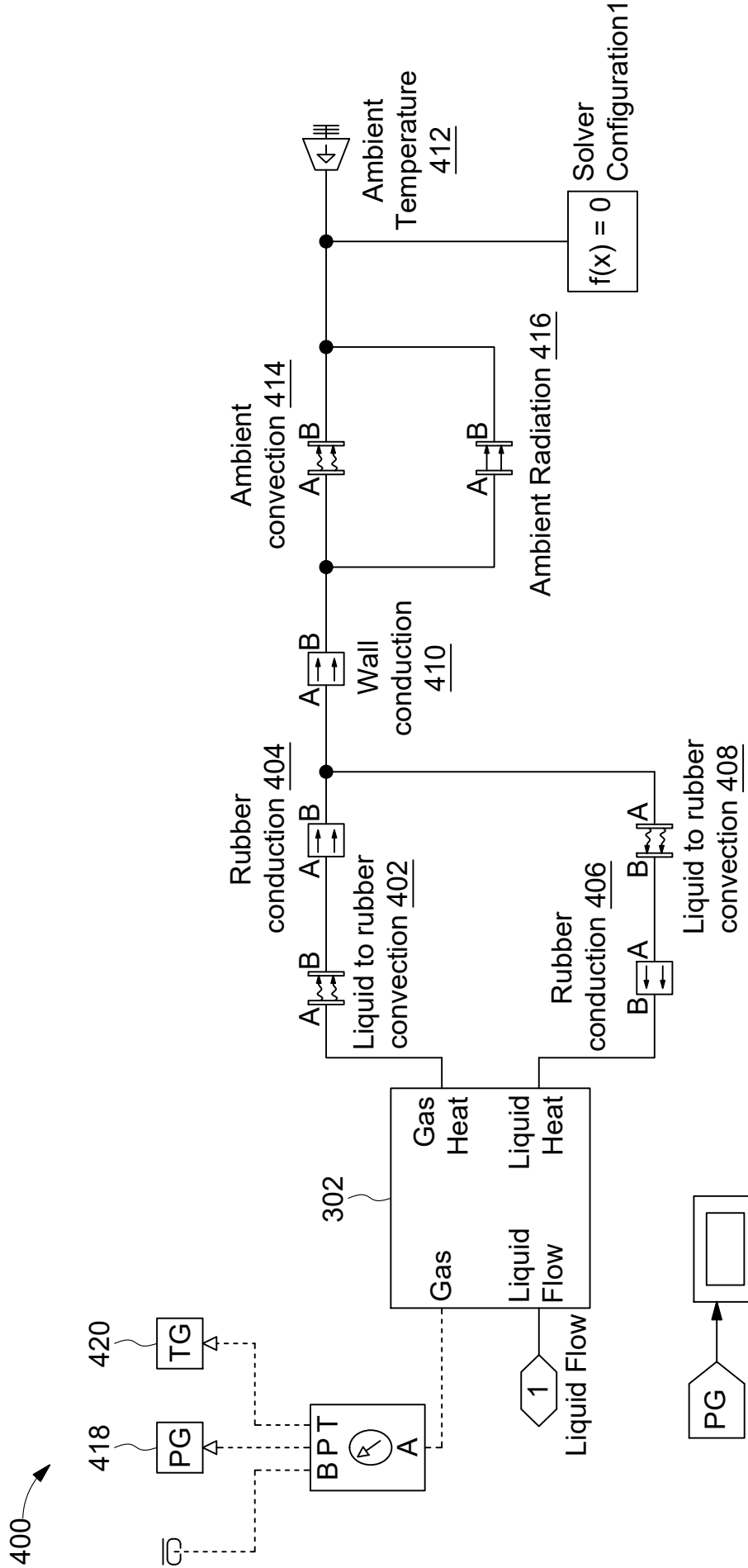

FIG. 4

400

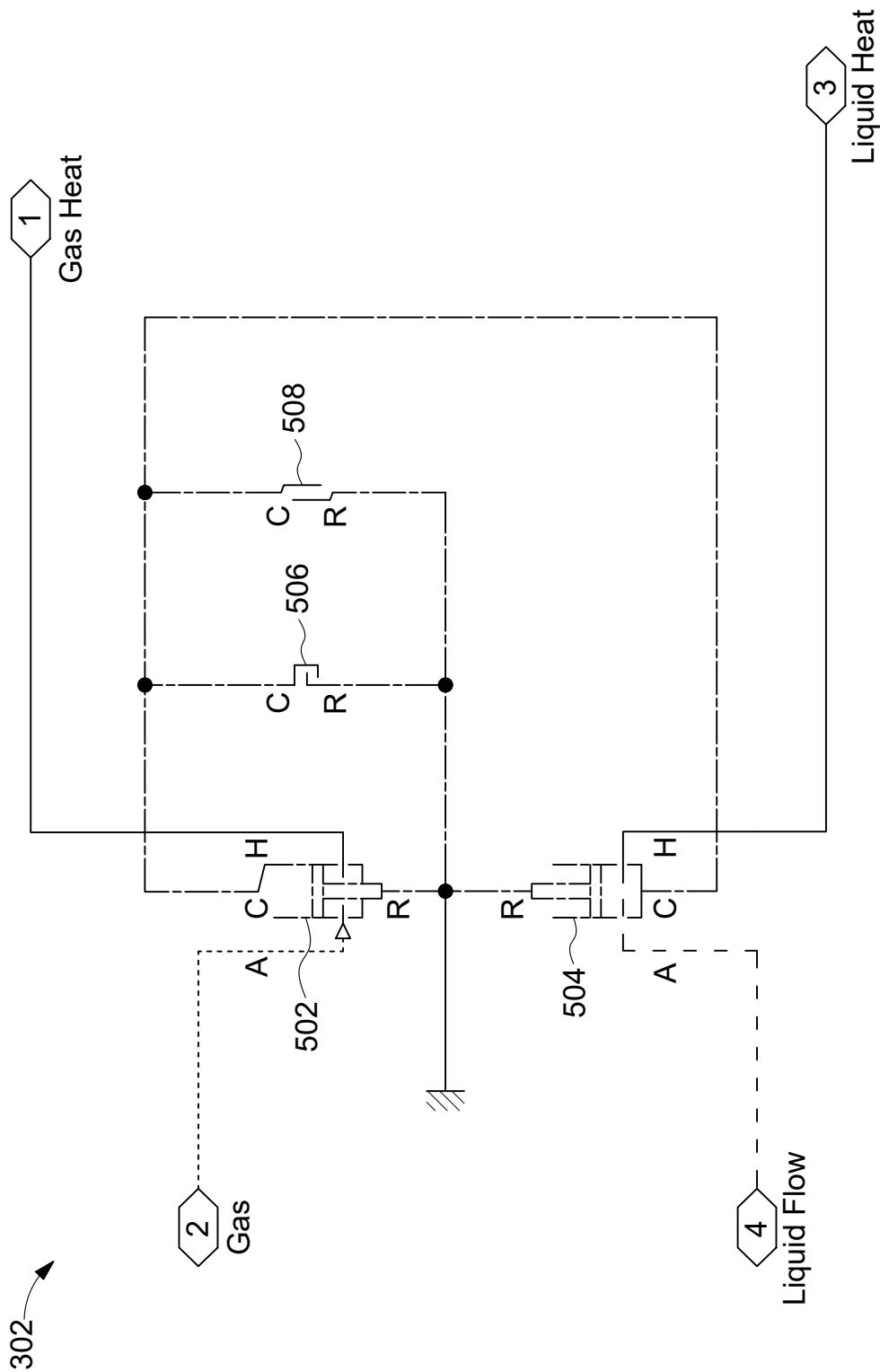

FIG. 5

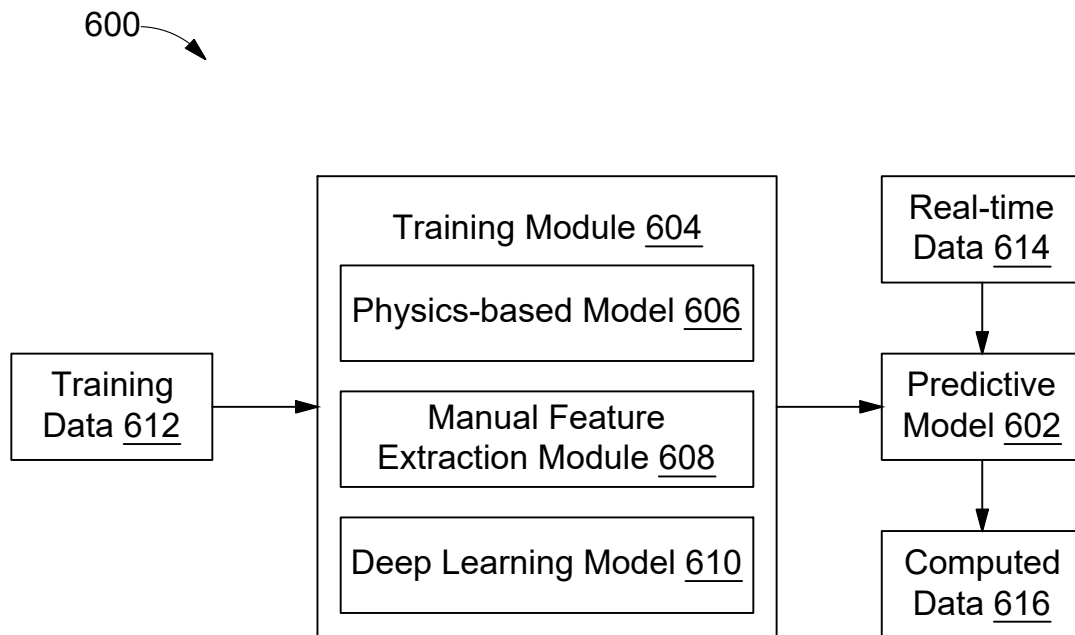

FIG. 6

700 →

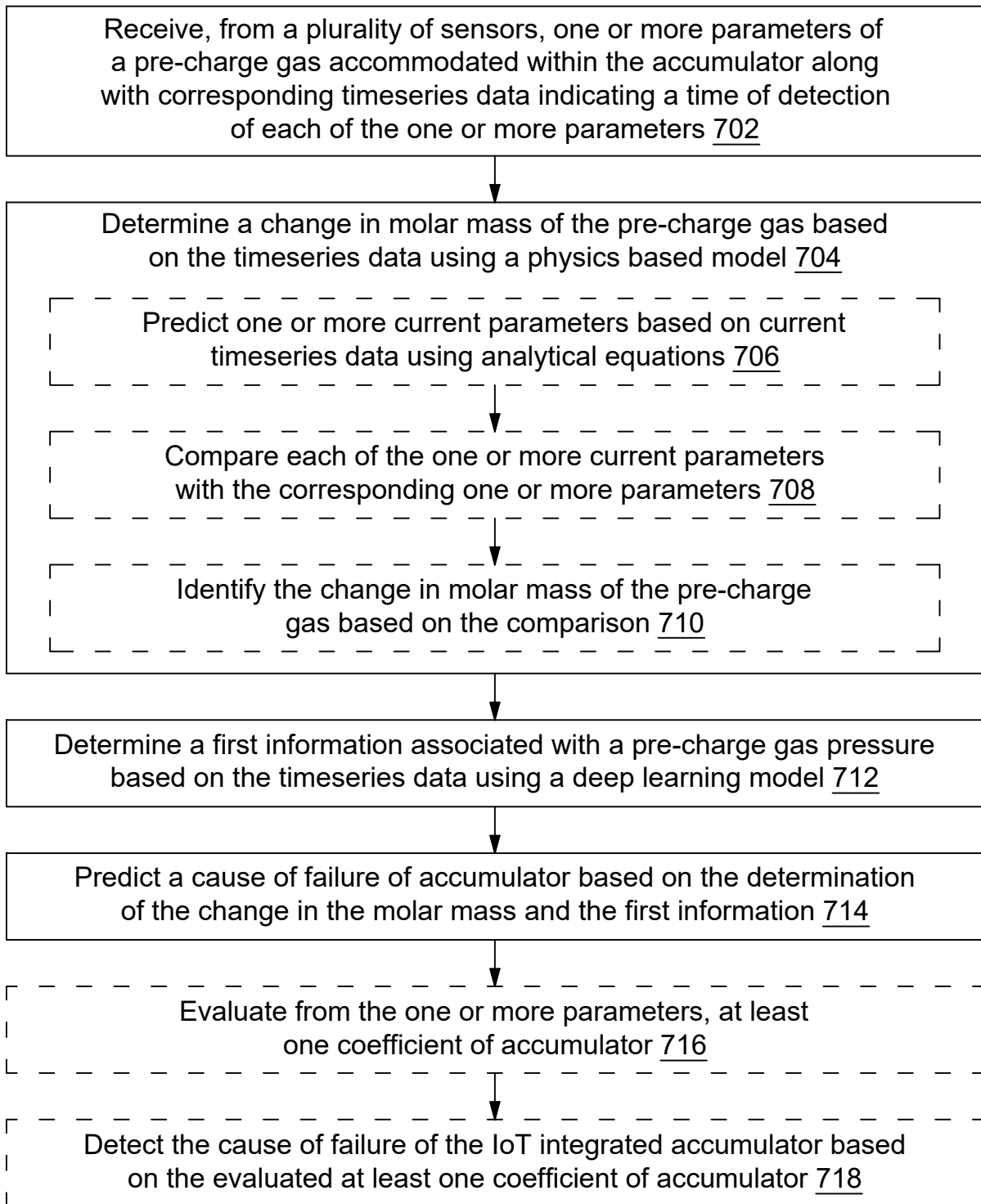

FIG. 7

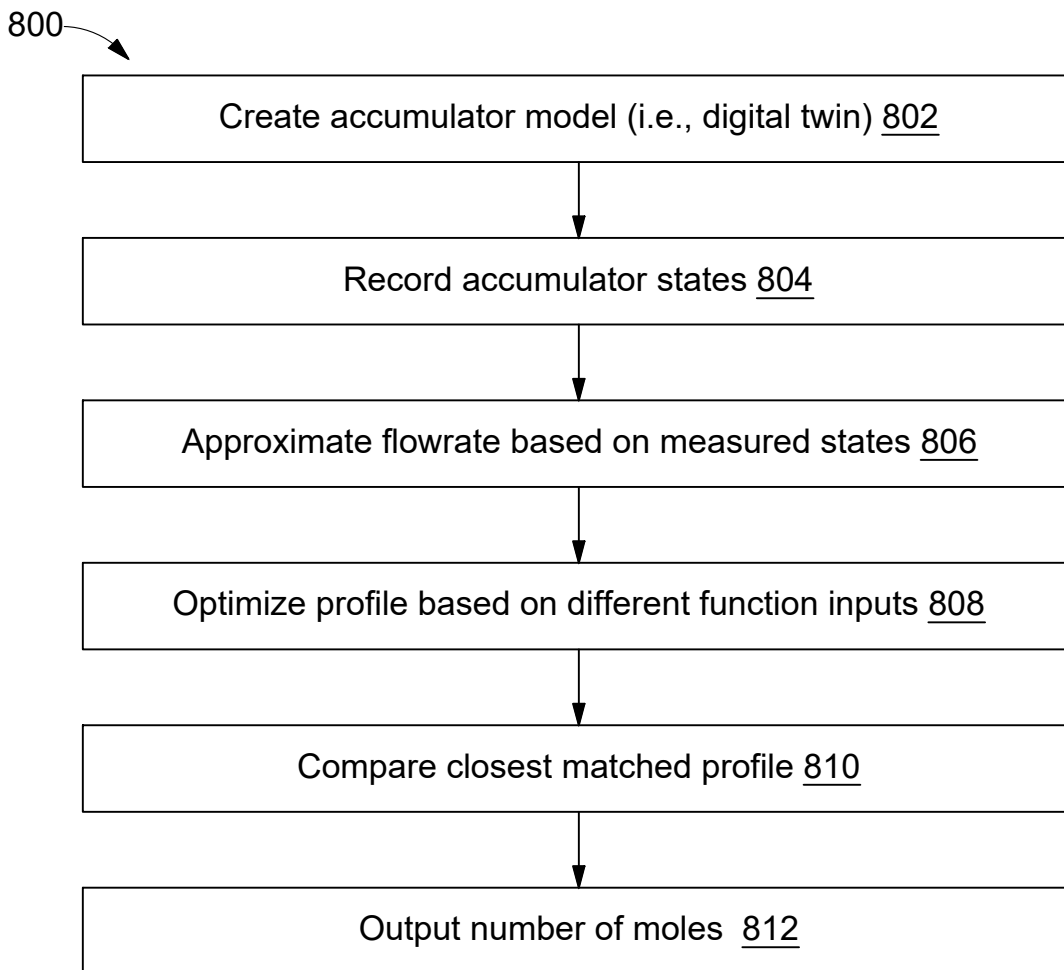

FIG. 8

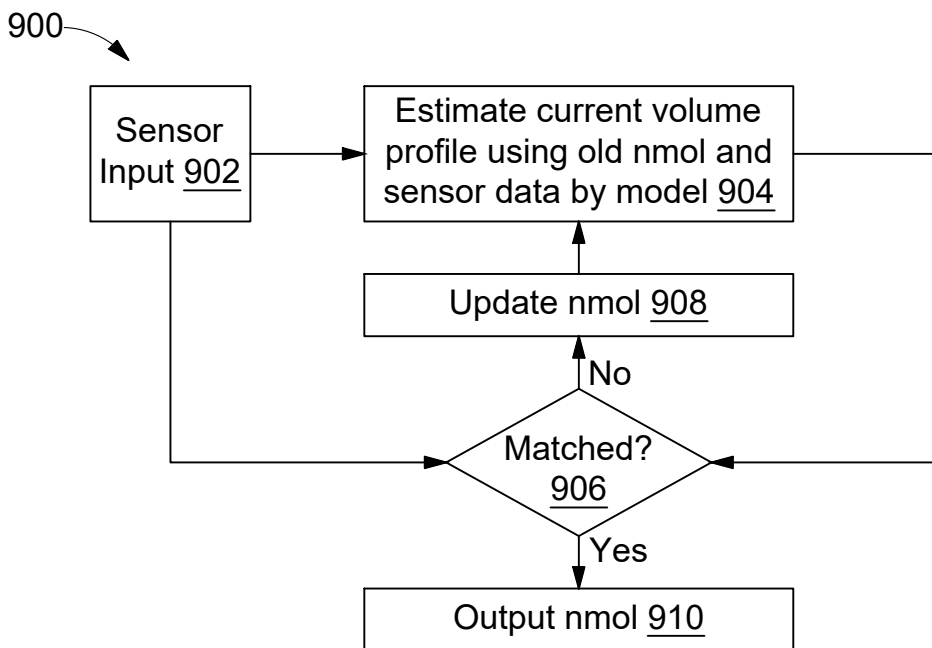

FIG. 9

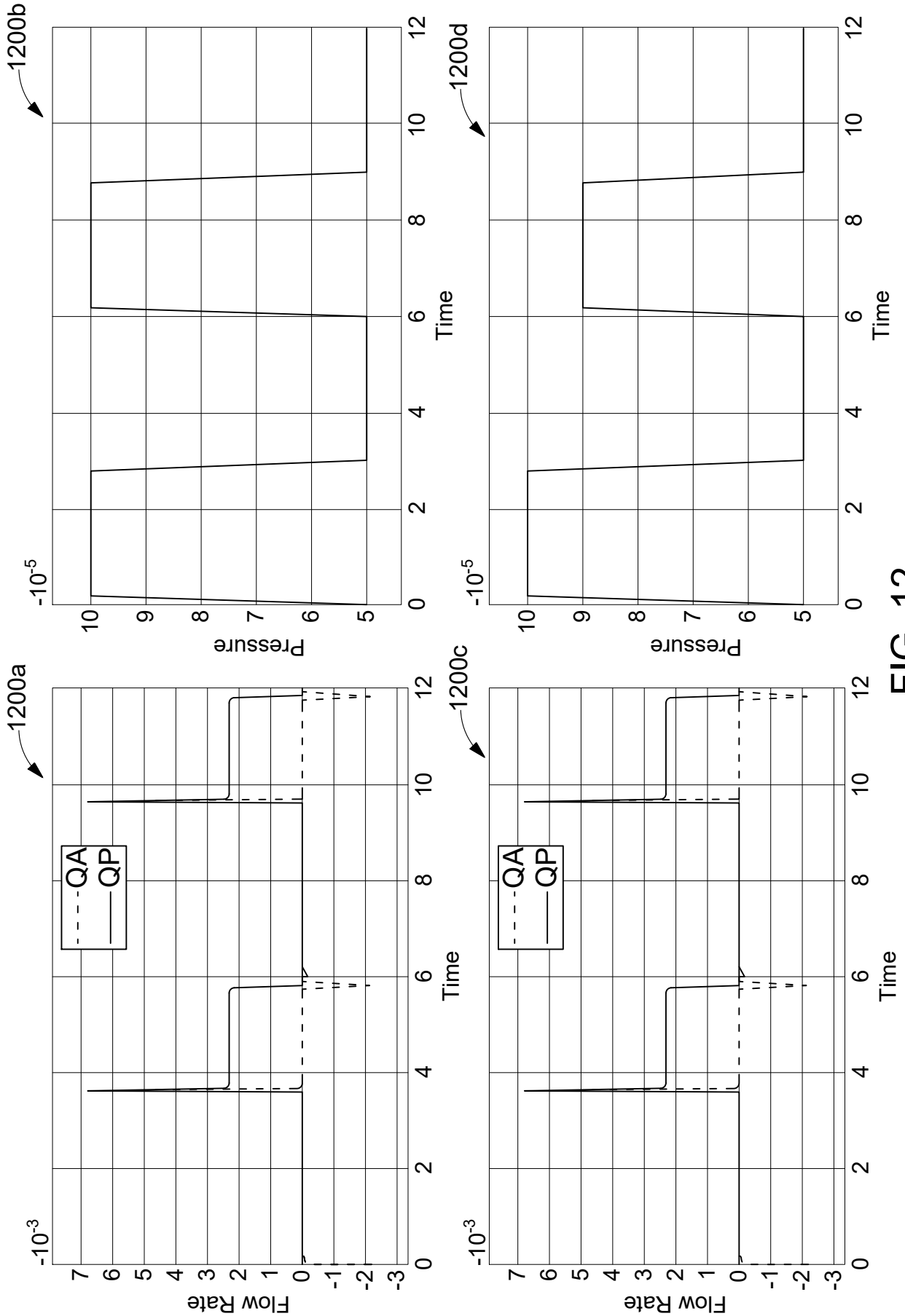

FIG. 12

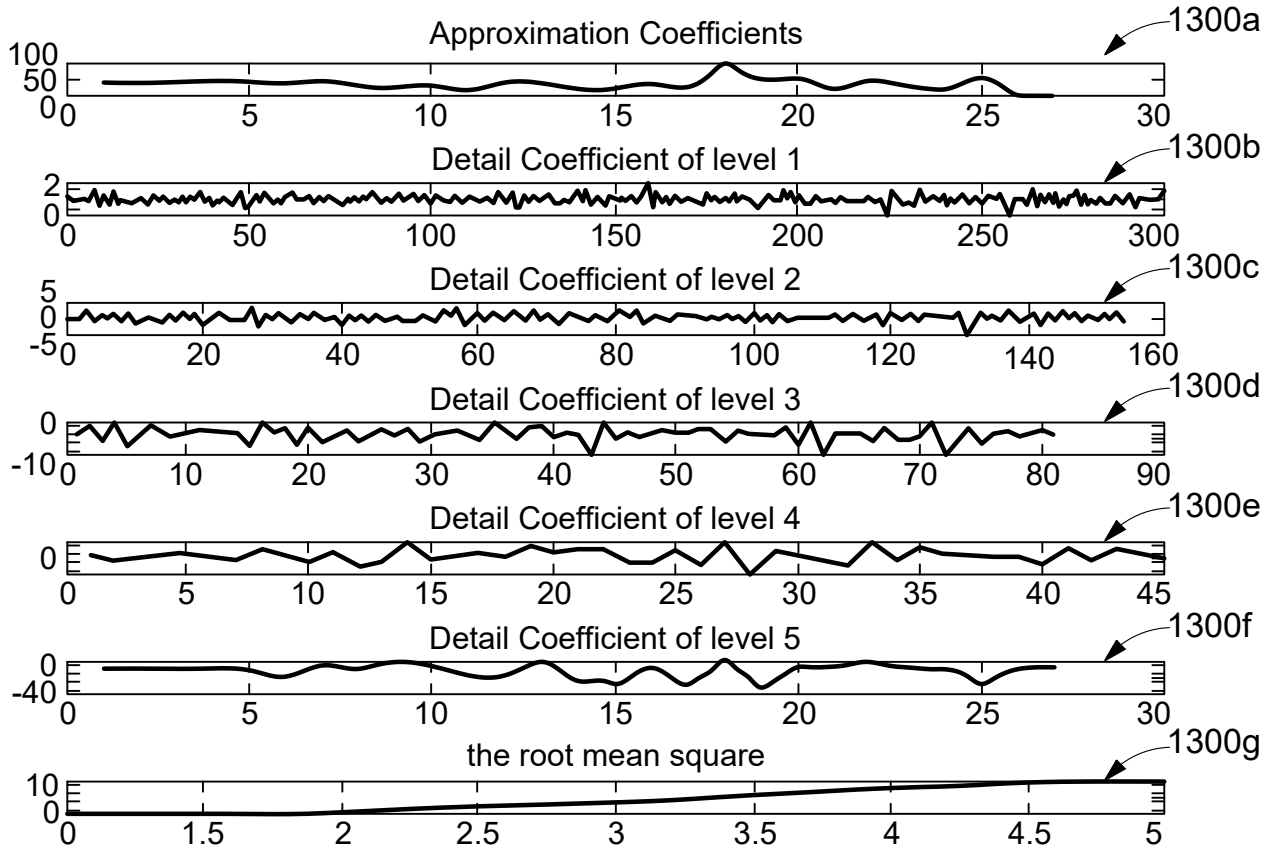

FIG. 13

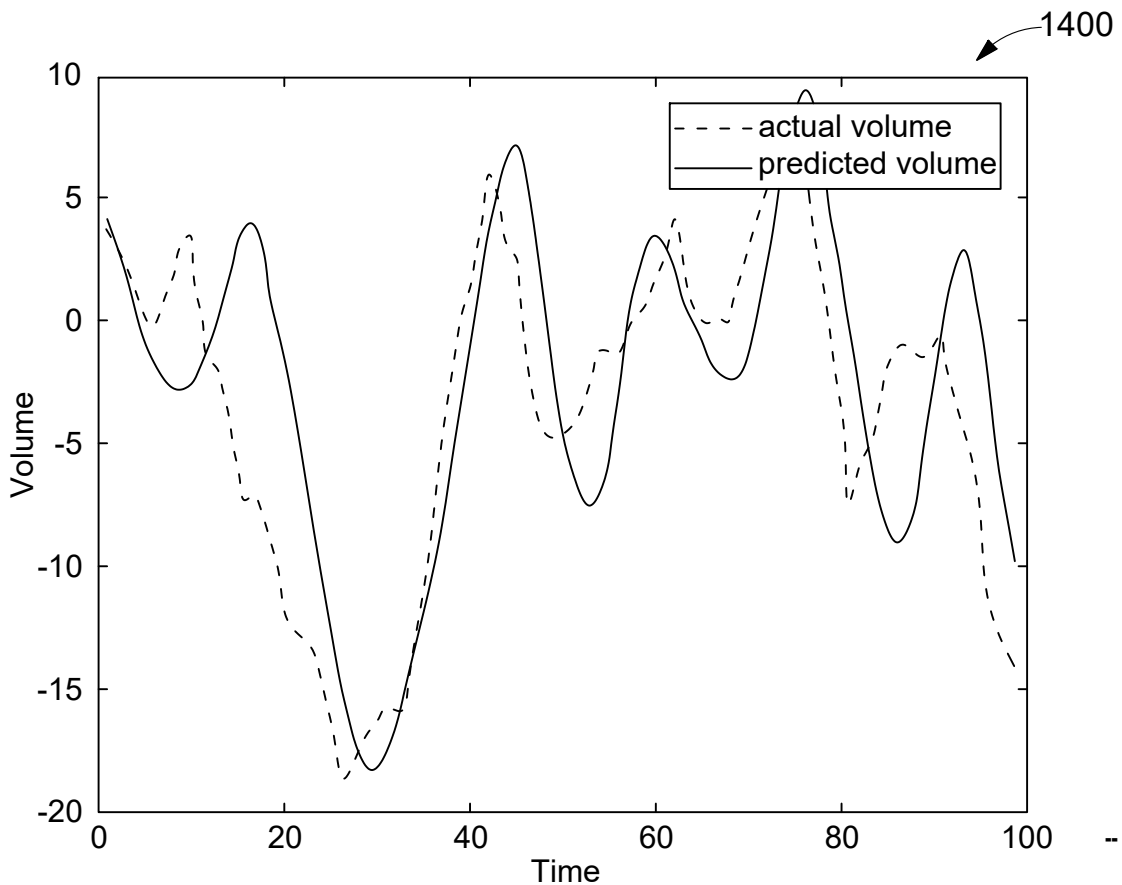

FIG. 14

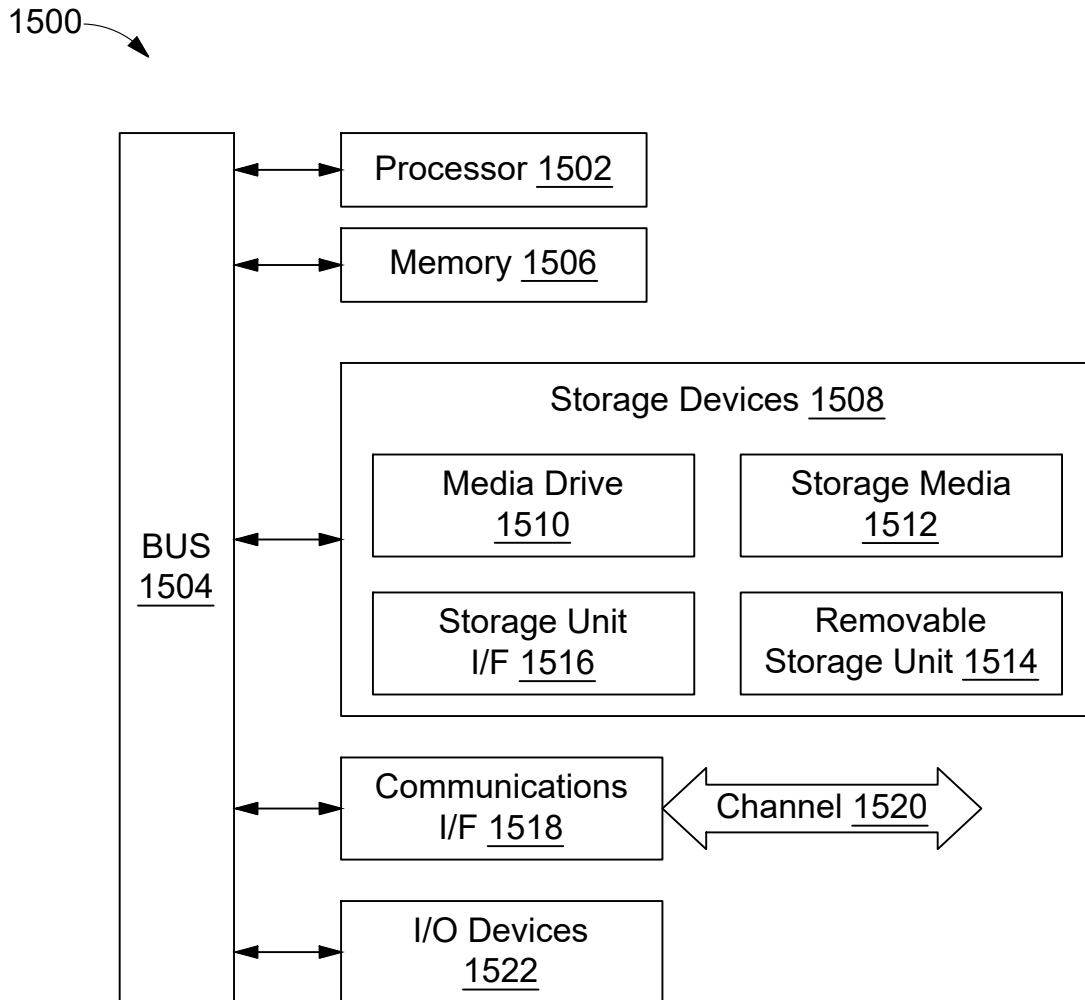

FIG. 15