

# (12) Indian Patent Application

(21) Application Number: 202341028822

(22) Filing Date: 20/04/2023      (43) Publication Date: 25/10/2024

(71) Applicant(s): L&T TECHNOLOGY SERVICES LIMITED

(72) Inventor(s): Kota, Siva Nageswara Rao  
                    Tiyyagura, Mohan Reddy

(51) International Classifications: B60W 50/00      G01R 31/319      G06F 12/0868      H04L 67/025      H04L 49/00

(54) Title: SWITCHING DEVICE AND INTERFACE

(57) Abstract: A switching device is provided including an input USB interface couplable to a testing device to electrically and communicably couple the switching device to the testing device. An input JTAG interface couplable to the testing device via at least one external device communicably couples the switching device to the testing device via the external device. An output JTAG interface couplable to the remote device communicably couples the remote device to the testing device via the switching device and the external device. An input ethernet interface is couplable to the testing device to communicably couple the switching device to the testing device. An output ethernet interface couplable to the remote device communicably couples the remote device to the testing device via the switching device. The switching device includes a controller to selectively switch the output JTAG interface or the output ethernet interface based on switching commands received from the testing device.

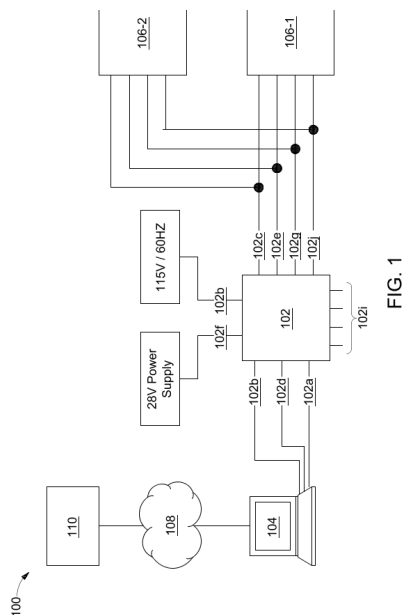

FIG. 1

Digitally Signed:  
Shanu Prasad  
(RPA No: 3253)  
Head, RPA Dept.  
L&T Technology Services Limited,  
Mumbai, India

# **FORM 2**

THE PATENTS ACT 1970  
(39 OF 1970)

&

The Patent Rules, 2003

## **Complete Specification**

(See Section 10 and Rule 13)

### **1. TITLE OF THE INVENTION**

**SWITCHING DEVICE AND INTERFACE**

### **2. APPLICANT(S)**

(a) NAME : **L&T TECHNOLOGY SERVICES LIMITED**

(b) NATIONALITY : **INDIAN**

(c) ADDRESS : **DLF IT SEZ Park, 2nd Floor – Block 3**

**1/124, Mount Poonamallee Road,**

**Ramapuram, Chennai – 600 089,**

**INDIA.**

### **3. PREAMBLE TO THE DESCRIPTION**

#### **COMPLETE**

The following specification describes the invention and the manner in which it is to be performed

## **DESCRIPTION**

### **Technical Field**

[001] This disclosure relates generally to embedded systems, and more particularly to a switching device and interface for legacy devices.

5

### **BACKGROUND**

Industries like aerospace and spacecraft depends on legacy devices to manage logistics operations. In an exemplary way a line replaceable unit (LRU) is used in aerospace and spacecraft industry. The line replaceable unit (LRU) is a modular component of an airplane, ship or spacecraft that is designed to be replaced quickly at an operating location restore the system into operational ready condition while the failed unit is undergoing maintenance. However, LRUs, cannot be remotely tested or configured. An LRU is usually a sealed unit such as a radio or other auxiliary equipment.

10

[002] Existing testing methods consist of mechanical switches to perform operations on LRU like switching power supply to the LRU and testing various other operations of the aircraft enabled using the LRU. Also, with the existing system setup, software engineering activities cannot be performed from remote location as it requires presence of an operator operating the mechanical switches to control the operations on the LRU.

15

[003] Therefore, there is a requirement to control and test the operations of legacy devices such as LRU remotely.

20

### **SUMMARY OF THE INVENTION**

[004] In an embodiment, a switching device is disclosed. The switching device may include an input universal bus (USB) interface couplable to a testing device to electrically and communicably couple the switching device to the testing device. Further, the switching device may include at least one input JTAG interface couplable to the testing device via at least one external device to communicably couple the switching device to the testing device via the at least one external device. The switching device may include at least one output JTAG interface couplable to at least one remote device to communicably couple the at least one remote device to the testing device via the switching device and the at least one external device. The switching device may also include an input ethernet interface couplable to the testing device to communicably couple the switching device to the testing device. The switching device may also include one output ethernet interface couplable to the at least one remote device to communicably couple the at least one remote device to the testing device via the switching device. The switching device may further include a controller to selectively switch the at least

25

30

one output JTAG interface or the at least one output ethernet interface based on one or more switching commands received from the testing device.

5 [005] In another embodiment, a method of testing at least one remote device is disclosed. The method may include initiating a switching device upon establishing a universal serial bus (USB) connection between a testing device and the switching device. Further, the method may include receiving, by the switching device, one or more switching commands from the testing device via a switching application rendered on the testing device. The switching device may enable at least one output JTAG interface or at least one output ethernet interface of the switching device based on the one or more switching commands. In an embodiment, the output JTAG interface may be communicatively coupled to the at least one remote device to establish a JTAG communication with the testing device via at least one external device and at least one input JTAG interface of the switching device. In an embodiment, the at least one output ethernet interface is communicatively coupled to the at least one remote device to establish an ethernet communication with the testing device via an input ethernet interface of the switching device. Further, the method may include testing the at least one remote device by at least either loading a firmware logic on a controller of the at least one remote device upon establishing the ethernet communication or emulating the controller of the at least one remote device (LRU) upon establishing the JTAG communication.

20 [006] In yet another embodiment, a graphical user interface (GUI) of a switching application rendered on a testing device to control a switching device. The GUI may include at least one primary display area corresponding to at least one remote device which may be communicably coupled to the switching device. In an embodiment, the one primary display area may include a first display area to enable user selection of a JTAG output interface between the switching device and the at least one remote device. Further, the one primary display area may include a second display area to enable user selection of an Ethernet output interface between the switching device and the at least one remote device. Furthermore, the one primary display area may include a third display area which may be enabled upon user selection of the Ethernet output interface, to enable user selection of at least one of the one or more control signals within an Ethernet communication between the switching device and the at least one remote device.

## BRIEF DESCRIPTION OF THE DRAWINGS

[007] The accompanying drawings, which are incorporated in and constitute a part of this disclosure, illustrate exemplary embodiments and, together with the description, serve to explain the disclosed principles.

5 [008] FIG. 1 illustrates a block diagram of a testing system, in accordance with an embodiment of the present disclosure.

[009] FIG. 2 illustrates is a circuit diagram of the switching device, in accordance with an embodiment of the present disclosure.

10 [010] FIG. 3A illustrates an exemplary switching device comprising a plurality of DC power input interfaces, a plurality of DC output interfaces and a plurality of AC power output interfaces, in accordance with an embodiment of the present disclosure.

[011] FIG. 3B illustrates an exemplary switching device comprising an input JTAG interface and a plurality of output JTAG interfaces, in accordance with an embodiment of the present disclosure.

15 [012] FIG. 3C illustrates an exemplary switching device comprising an input ethernet interface and a plurality of output ethernet interfaces, in accordance with an embodiment of the present disclosure.

[013] FIG. 3D illustrates an exemplary switching device comprising an output control signal interface, in accordance with an embodiment of the present disclosure.

20 [014] FIG. 4A, FIG. 4B, FIG. 4C, FIG. 4D, FIG. 4E, FIG. 4F and FIG. 4G illustrate a digital graphical user interface (GUI) of a switching application is illustrated, in accordance with the present disclosure.

[015] FIG. 5 illustrates a flow diagram illustrating a method of testing at least one remote device, in accordance with an embodiment of the present disclosure.

25

## DETAILED DESCRIPTION OF THE DRAWINGS

[016] Exemplary embodiments are described with reference to the accompanying drawings. Wherever convenient, the same reference numbers are used throughout the drawings to refer to the same or like parts. While examples and features of disclosed principles are described herein, modifications, adaptations, and other implementations are possible without departing from the scope of the disclosed embodiments. It is intended that the following detailed description be considered as exemplary only, with the true scope being indicated by the following claims. Additional illustrative embodiments are listed.

30

[017] Presently, mechanical switches are used to perform operations on remote devices like enabling or disabling power supply to the remote device, or enabling or disabling transmission of communication signals. The switching device of the present disclosure allows control of remote device includes but not limited to line replaceable units (LRUs) used in different industries like shipment, aerospace, spacecraft. Further, the present disclosure provides an interface of a switching application for controlling operations of remote device remotely.

[0001] Referring now to **FIG. 1**, a block diagram of testing system 100 is illustrated, in accordance with an embodiment of the present disclosure. By way of an example, the testing system 100 may include a switching device 102 connected to a testing device 104 and a plurality of remote devices 106-1, 106-2, (which are collectively referred to as remote devices 106 and individually referred to as the at least one remote device 106, hereinafter). The switching device 102 may include an input universal bus (USB) interface 102a couplable to the testing device 104. Accordingly, the switching device 102 is electrically and communicably coupled to the testing device 104. In an embodiment, based on the coupling of the switching device 102 with the testing device 104 via the input USB interface 102a a USB connection may be established. In an embodiment, the switching device 102 may be powered based on the establishment of the USB connection and a switching application may be installed on the testing device 104. The testing device 104 may include a variety of computing systems, including but not limited to, a laptop computer, a desktop computer, a portable computer, a personal digital assistant, a handheld, or a mobile device. Further, one or more remote devices 110 may communicate with the testing device 104 through a wireless or wired communication network 108. Accordingly, the testing device 104 may enable a user to provide one or more switching commands from the switching application rendered on the testing device 104 to the switching device 102. In an embodiment, the switching application may be, but not limited to, a python based graphic user interface. In an embodiment, the switching device 102 may be plug and play device. In an embodiment, the testing device 104 may receive the switching commands from a user device 110 connected to the testing device 104 via a remote desktop protocol over a communication network 108. The network 108 can be implemented as one of the different types of networks, such as intranet, local area network (LAN), wide area network (WAN), the internet, Wi-Fi, LTE network, CDMA network, and the like. Further, the network 108 can either be a dedicated network or a shared network. The shared network represents an association of the different types of networks that use a variety of protocols, for example,

Hypertext Transfer Protocol (HTTP), Transmission Control Protocol/Internet Protocol (TCP/IP), Wireless Application Protocol (WAP), and the like, to communicate with one another. Further the network 108 can include a variety of network devices, including routers, bridges, servers, computing devices, storage devices, and the like.

5           **[018]**    The switching device 102 may also include at least one input Joint Test Action Group (JTAG) interface 102b couplable to the testing device 104 via at least one external device (not shown) to communicably couple the switching device 102 to the testing device 104 via the at least one external device (not shown). The external device may include but not limited to one or more emulators, like CPU Sim, QEMU, SPIM, DOSBox, Rosetta, etc. The switching  
10    device 102 may also include at least one output JTAG interface 102c couplable to at least one of the remote devices 106 to communicably couple the at least one remote device 106 to the testing device 104 via the switching device 102 and the at least one external device (not shown). A communication between the testing device 104, the external device (not shown), and the remote device 106 may be enabled via the switching device 102 by establishing a JTAG  
15    communication through the input JTAG interface 102b and the output JTAG interface 102c. The JTAG communication may enable emulation of a controller 112 (shown in FIG. 1B) of the switching device 102 by an external device such as an emulator.

**[019]**    The switching device 102 may also include at least one input ethernet interface 102d couplable to the testing device 104 to communicably couple the switching device 102 to  
20    the testing device 104. The switching device 102 may also include at least one output ethernet interface 102e couplable to the at least one remote device 106 to communicably couple the at least one remote device 106 via the switching device 102. Based on the coupling of the input ethernet interface 102d with the testing device 104 and the coupling of the output ethernet interface 102e with the remote device 106, the switching device 102 is communicatively  
25    couples the at least one remote device 106 with the testing device 104 by establishing an ethernet communication. In an embodiment, the ethernet communication may be a standard Ethernet-based local area network.

**[020]**    In an embodiment, the switching device 102 may further include a plurality of DC power input interfaces 102f, each couplable to an input DC power source to electrically  
30    power a corresponding DC output interface 102g. In an embodiment the corresponding DC output interface 102g may be couplable to the at least one remote device 106 to selectively power the at least one remote device 106. In an embodiment, the switching device 102 may

switch power to each of the DC output interface 102g independently of each other using one or more relays.

[021] In an embodiment, the switching device 102 may also include an AC input interface 102h couplable to an AC power source to electrically power a plurality of AC power output interfaces 102i. In an embodiment, the switching device 102 may switch power to each of the plurality of AC power output interfaces 102i independently of each other using one or more relays.

[022] In an embodiment, the switching device 102 may also include a control signal interface 112j couplable to the at least one remote device 106 for transmitting one or more control signals from the testing device 104 and the at least one remote device 106. In an embodiment, the control signal interface 112j may be, but not limited to, a 10 pin terminal block.

[023] Referring now to **FIG. 2** is a circuit diagram 200 of the switching device 102, in accordance with the present disclosure. By way of an example the switching 102 may include a micro controller 202, a plurality of normal close (NC) relays 204, 206, a plurality of relay drivers 208, 210, 212, 214, a JTAG switch 216, a LAN switch 218, a 10-pin terminal block 220, 6-pin programming connector 222, and a voltage regulator 224.

[024] In another embodiment, the switching device 102 may include a microcontroller 202 which may be, but not limited to, 8-bit microcontroller, 16-bit microcontroller, 32-bit microcontroller, external memory microcontroller, embedded memory microcontroller, complex instruction set computer (CISC), reduced instruction set computers (RISC), etc. The microcontroller 202 may receive one or more input signals from the testing device 104 via one or more input interfaces. Among other capabilities, the microcontroller 202 may be configured to fetch and execute computer-readable instructions stored in a memory (not shown). The memory may store one or more computer-readable instructions or routines, which may be fetched and executed to create or share the data units or control signals over from one or more input interfaces to the one or more output interfaces. The memory may comprise any non-transitory storage device including, for example, volatile memory such as RAM, or non-volatile memory such as EPROM, flash memory, and the like. The microcontroller 202 may switch the one or more input signals to the one or more output interfaces based on one or more switching commands received from the testing device 104 via the USB connection.

[025] The switching device 102 may include a plurality of normal close (NC) relays 204 and 206 which may be selectively closed to enable transmission of DC power from each

of the plurality of DC power input interfaces 102f to the corresponding DC output interface 102g based on a relay driver 208 which may be operated based on the one or more switching commands received from the microcontroller 202. Accordingly, the relay driver 208 may operate one of the plurality of normal close (NC) relays 204 and 206 in order to transmit DC power to the corresponding DC output interface 102g which in turn may power the corresponding remote device 106.

**[026]** **FIG. 3A** illustrates an exemplary switching device comprising a plurality of DC power input interfaces, a plurality of DC output interfaces and a plurality of AC power output interfaces 102i, in accordance with an embodiment of the present disclosure. The switching device 102 as shown in **FIG. 3A** shows a plurality of DC power input interfaces 102f are provided as banana connector or jacks to enable plugging of a plug of DC power source. Further, the plurality of DC output interfaces 102g are provided as banana connector or jacks to enable plugging of a plug of remote devices 106 to transmit DC power. Further, the switching device 102 may include plurality of AC power output interfaces 102i which may be couplable to the at least one external device (not shown) to transmit AC power to the corresponding external device plugged into any one of the plurality of AC power output interfaces 102i. In an embodiment, the circuitry of the switching device 102 may also include a set of second relays (not shown) to selectively power the plurality of AC power output interfaces 102i based on the one or more switching commands.

**[027]** In an embodiment, the microcontroller 202 may receive signals from at least one input JTAG interface 102b and selectively switch the signals to at least one output JTAG interface 102c using a JTAG switch 216. **FIG. 3B** illustrates an exemplary switching device comprising an input JTAG interface 102b and a plurality of output JTAG interfaces 102c, in accordance with an embodiment of the present disclosure. In an embodiment, an external device 302 such as, but not limited to, a JTAG Debugger or an emulator may be connected between the testing device 104 and to the input JTAG interface 102b of the switching device 102. The emulator 302 may enable emulation of a controller (not shown) of the remote device 106 based on one or more control signals received from the testing device 104. The one or more control signals may be transmitted to the remote device 106 using at least one output JTAG interface 102c which is coupled to the remote device 106.

**[028]** Further, the microcontroller 202 may transmit or receive one or more communication signals from the testing device 104 coupled to the least one input ethernet interface 102d. The microcontroller 202 may transmit or receive the communication signal to the at least one of output ethernet interface 102e by switching the LAN switch 216 based on

one or more switching commands received from the testing device 104. Accordingly, the one or more communication signals may be transmitted or received from the at least one remote devices 106 coupled to the output ethernet interface 102e of the switching device 102.

5 [029] FIG. 3C illustrates an exemplary switching device comprising an input ethernet interface 102d and a plurality of output ethernet interfaces 102e, in accordance with an embodiment of the present disclosure. In an embodiment, the testing device 104 may be connected to the input ethernet interface 102d of the switching device 102. The communication signals may be received by or transmitted from the testing device 104 to the remote device 106 based on switching of the LAN switch 218 based on one or more switching commands received  
10 from the testing device 104. The one or more communication signals may be received by or transmitted to respectively by the remote device 106 which may be coupled to the plurality of output ethernet interfaces 102e. Accordingly, an ethernet communication interface may be established between the testing device 104 and the remote devices 106 via the switching device 102.

15 [030] The microcontroller 202 may switch one or more control signals such as, but not limited to, test link and boot signals received from the testing device 104 and transmitted to the at least one remote device 106 using one or more pins of the plurality of output ethernet interfaces 102e. In an embodiment, the one or more control signals received from the testing device 104 may be used for testing, debugging and loading firmware of a controller of the  
20 remote device 106. In an embodiment, the boot signal may be used to upload the firmware and the test link signal may use to test the firmware. The switching device 102 may include relay drivers 210 and 212 for switching the control signals to at least one of the plurality of output ethernet interfaces 102e based on the switching commands received from the testing device 104.

25 [031] In an embodiment, the switching device 102 may include a control signals interface 220 which may include, but not limited to, a 10 pin terminal block, and may be used to transmit control signals such as, but not limited to, a watch dog disable (WDD) signal, a power on reset (POR) signal, etc. to the remote device 106. In an embodiment, the watchdog disable signal may be used to detect and recover from computer malfunctions, the power on  
30 reset signal may use to generate a reset signal when power has been enabled to the remote device 106, it ensures that the remote device 106 starts operating in a known state. The switching device 102 may also comprise a set of third relays 214 to selectively enable the one or more control signals based on the one or more switching commands received from the testing device 104. FIG. 3D illustrates an exemplary switching device comprising an output control

signal interface 112j, in accordance with an embodiment of the present disclosure. The output control signal may be coupled to the remote devices 106 to transmit control signals via by switching the relay driver 214 by the microcontroller 202. The switching 102 includes one or more connection LEDs 304, 306 and 308. The LED 306 may be illuminated based on powering of the switching device 102. LEDs 304 and 308 are illuminated to acknowledge the one or more switching commands transmitted to or received from the testing device 104.

[032] Referring now to **FIG. 4A**, a digital graphical user interface (GUI) of a switching application is illustrated, in accordance with the present disclosure. In an embodiment, the switching commands are received from the testing device 104 via the GUI 400A of the switching application rendered on the testing device 104. In an embodiment, the GUI 400A is rendered based on installation of the switching application on the testing device 104 upon coupling of the testing device 104 with the switching device 102 via the input USB interface 102a.

[033] In an exemplary embodiment, the GUI 400A may comprise at least one user selectable option 402 to scan coupling of the input USB interface 102a to the testing device 104. The GUI 400A may further include at least one selectable option 404 to select a communication port connection to the switching device 102 selected.

[034] The GUI 400A may further include primary display areas 406 each corresponding to a remote device 106 coupled to the switching device 102. The primary display area 406 may include a first display area 408 to enable user selection of at least one of the plurality of JTAG output interfaces 102c (as shown in **FIG. 1** and **FIG. 2**) to establish a JTAG communication between the testing device 104, the remote device 106 via the switching device 102 and an external device (not shown). **FIG. 4B** illustrates the GUI 400B of the switching application depicting the first display area 408, in accordance with an embodiment of the present disclosure. The first display area 408 depicts enabling of the one of the plurality of JTAG output interfaces 102c based on the user selection.

[035] The primary display area 406 may include a second display area 410 to enable user selection of enabling an output ethernet interface 102e in order to establish an ethernet communication between the testing device 104 and the at least one remote device 106. **FIG. 4C** illustrates the GUI 400C of the switching application depicting the second display area 410, in accordance with an embodiment of the present disclosure. The second display area 410 depicts enabling of the one of the plurality of output Ethernet interfaces 102e based on the user selection.

[036] The primary display area 406 may include a third display area 412 which may be enabled upon user selection of the Ethernet output interface 102e. The third display area 412 may allow enabling transmission of at least one of the one or more control signals such as, but not limited to, test link and boot signals received from the testing device 104 to the at least one remote device 106 using one or more pins of the plurality of output ethernet interfaces 102e. FIG. 4D and FIG. 4E illustrate the GUIs 400D and 400E respectively of the switching application depicting the third display area 412, in accordance with an embodiment of the present disclosure. The third display area 412 depicts enabling of the control signals such as, but not limited to, test link and boot signals based on the user selection. Wherein the one or more control signals such as, but not limited to, test link and boot signals may be transmitted to the remote device 106 based on the user selection and upon establishment of the ethernet communication between the switching device 102 and the at least one remote device 106.

[037] In an embodiment, the GUI 400A may include a fourth display area 414 comprising a plurality of user selectable areas 416a-e to enable at least one AC output port 102i of the switching device 102. In an embodiment, the GUI 400A may include a fifth display area 418 to enable user selection of at least one DC output interface 102g of the switching device 102 to enable transmission of DC power from one of the DC power input interfaces 102f.

[038] FIG. 4F and FIG. 4G illustrate the GUI 400F and 400G respectively of the switching application depicting a sixth display area 420 and a seventh display area 422, in accordance with an embodiment of the present disclosure. The sixth display area 420 depicts enabling of the control signals such as, one power on reset (POR) control signal which may be transmitted to the remote device 106 based on user selection. The seventh display area 422 depicts enabling of the control signals such as, watch dog disable (WDD) signals which may be transmitted to the remote device 106 based on user selection. The control signals such as, one power on reset (POR) control signal and watch dog disable (WDD) signals, may be transmitted to the remote device 106 via the control signal interface 220 which may be a, but not limited to, a 10 pin terminal block in the switching device 102.

[039] FIG. 5 is a flow diagram 500 illustrating a method of testing at least one remote device, in accordance with an embodiment of the present disclosure.

[040] At step 502, a switching device may be initiated upon establishing a USB connection between a testing device 104 and the switching device 102. At step 504, one or more switching commands may be received from the testing device 104 via a switching application rendered on the testing device 104. At step 506, at least one output JTAG interface 102c or at least one output ethernet interface 102e of the switching device 102 may be enabled

based on the one or more switching commands. At step 508, a JTAG communication with the testing device 104 via at least one external device 302 and at least one input JTAG interface 102b of the switching device 102 may be established by communicatively coupling the at least one output JTAG interface 102c to the at least one remote device 106. At step 510, the at least one output ethernet interface 102e may be communicatively coupled to the at least one remote device 106 to establish an ethernet communication with the testing device 104 via an input ethernet interface 102d of the switching device 102. At step 512, the at least one remote device 106 may be tested by either loading a firmware logic on a controller of the at least one remote device upon establishing the ethernet communication or by emulating the controller of the at least one remote device upon establishing the JTAG communication.

**[041]** It is intended that the disclosure and examples be considered as exemplary only, with a true scope of disclosed embodiments being indicated by the following claims.

**WE CLAIM:**

1. A switching device (102), comprising:

an input universal serial bus (USB) interface (102a) couplable to a testing device (104) to electrically and communicably couple the switching device (102) to the testing device (104);

at least one input JTAG interface (102b) couplable to the testing device (104) via at least one external device to communicably couple the switching device (102) to the testing device (104) via the at least one external device;

at least one output JTAG interface (102c) couplable to at least one remote device to communicably couple the at least one remote device to the testing device (104) via the switching device (102) and the at least one external device;

an input ethernet interface (102d) couplable to the testing device (104) to communicably couple the switching device (102) to the testing device (104);

at least one output ethernet interface (102e) couplable to the at least one remote device to communicably couple the at least one remote device to the testing device (104) via the switching device (102); and

a controller to selectively switch the at least one output JTAG interface (102c) or the at least one output ethernet interface (102e) based on one or more switching commands received from the testing device (104).

2. The switching device (102) as claimed in claim 1, comprising:

a plurality of DC power input interfaces (102f), each couplable to an input DC power source to electrically power a corresponding DC output interface (102g), wherein the corresponding DC output interface (102g) is couplable to the at least one remote device (106); and

a set of first relays (204, 206, 208) to selectively power the corresponding DC output interface (102g) based on the one or more switching commands.

3. The switching device (102) as claimed in claim 1, comprising:

an AC input interface (102h) couplable to an AC power source to electrically power a plurality of AC power output interfaces (102i), wherein at least one of the plurality of AC power output interfaces (102i) is couplable to the at least one external device (302); and

a set of second relays to selectively power the plurality of AC power output interfaces based on the one or more switching commands.

4. The switching device (102) as claimed in claim 1, comprising:
  - a control signal interface (220) couplable to the at least one remote device (106) for transmitting one or more control signals between the testing device (104) and the at least one remote device (106); and
  - a set of third relays (214) to selectively enable the one or more control signals based on the one or more switching commands.
  
5. The switching device (102) as claimed in claims 1, comprising:
  - a JTAG switch (216) to selectively enable the at least one output JTAG interface (102c);
  - a LAN switch (218) to selectively enable the at least one output ethernet interface (102e); and
  - a set of fourth relays (210, 212) to selectively enable one or more control signals within an Ethernet communication channel of the at least one output ethernet interface (102e).
  
6. The switching device (102) as claimed in claim 1, comprises one or more connection LEDs (304, 308), wherein the one or more connection LEDs (304, 308) are illuminated based on the one or more switching commands received from the testing device (104).
  
7. The switching device (102) as claimed in claim 1, wherein the one or more switching commands are received from the testing device (102) via a switching application (400A) rendered on the testing device (104), and wherein the switching application (400A) is installed on the testing device (104) upon coupling of the testing device (104) with the switching device (102) via the input USB interface (102a).
  
8. A method of testing at least one remote device, the method comprising:
  - initiating a switching device (102) upon establishing a universal serial bus (USB) connection between a testing device (104) and the switching device (102);
  - receiving, by the switching device(102), one or more switching commands from the testing device (104) via a switching application (400A) rendered on the testing device (104);
  - enabling, by the switching device (102), at least one output JTAG interface (102c) or at least one output ethernet interface (102e) of the switching device (102) based on the one or more switching commands,
  - wherein the at least one output JTAG interface (102c) is communicatively coupled to the at least one remote device (106) to establish a JTAG communication

with the testing device (104) via at least one external device (106) and at least one input JTAG interface (102b) of the switching device (102),

wherein the at least one output ethernet interface (102e) is communicatively coupled to the at least one remote device (106) to establish an ethernet communication with the testing device (104) via an input ethernet interface (102d) of the switching device (102),

testing the at least one remote device (106) by at least one of:

loading a firmware logic on a controller of the at least one remote device upon establishing the ethernet communication; or

emulating the controller of the at least one remote device upon establishing the JTAG communication.

9. The method as claimed in claim 8, comprising:

enabling, by the switching device (102), one or more control signals of a control signal interface based on the one or more switching commands, wherein the control signal interface is communicatively coupled to the at least one remote device for transmitting the one or more control signals between the testing device and the at least one remote device.

10. The method as claimed in claim 8, comprising:

enabling, by the switching device (102), one or more control signals within the Ethernet communication based on the one or more switching commands.

11. A graphical user interface (GUI) (400A) of a switching application rendered on a testing device (104) to control a switching device (102), the GUI (400A) comprising:

at least one primary display area (406) corresponding to at least one remote device (106) communicably and electrically coupled to the switching device (102), the at least one primary display area (406) comprising:

a first display area (408) to enable user selection of a JTAG output interface (102c) between the switching device (102) and the at least one remote device (106);

a second display area (410) to enable user selection of an Ethernet output interface (102e) between the switching device (102) and the at least one remote device (106);

a third display area (412), enabled upon user selection of the Ethernet output interface (102e), to enable user selection of at least one of the one or

more control signals within an Ethernet communication between the switching device (102) and the at least one remote device (106).

12. The GUI (400A) as claimed in claim 11, comprising:

a fourth display area (414) to enable user selection of at least one AC output port (102i) of the switching device (102); and

a fifth display area (414) to enable user selection of at least one DC output port (102f) of the switching device (102).

Dated this 20<sup>th</sup> day of April 2023

***-- Digitally Signed--***

Bhanu Prasad  
(INPA No: **3253**)  
Head, IPR Dept.,  
L&T Technology Services Limited,  
DLF 3rd Block, 2nd Floor,  
Manapakkam, Chennai - 600089.

## **ABSTRACT**

### **SWITCHING DEVICE AND INTERFACE**

A switching device is provided including an input USB interface couplable to a testing device to electrically and communicably couple the switching device to the testing device. An input JTAG interface couplable to the testing device via at least one external device communicably couples the switching device to the testing device via the external device. An output JTAG interface couplable to the remote device communicably couples the remote device to the testing device via the switching device and the external device. An input ethernet interface is couplable to the testing device to communicably couple the switching device to the testing device. An output ethernet interface couplable to the remote device communicably couples the remote device to the testing device via the switching device. The switching device includes a controller to selectively switch the output JTAG interface or the output ethernet interface based on switching commands received from the testing device.

*[To be published with FIG. 1]*

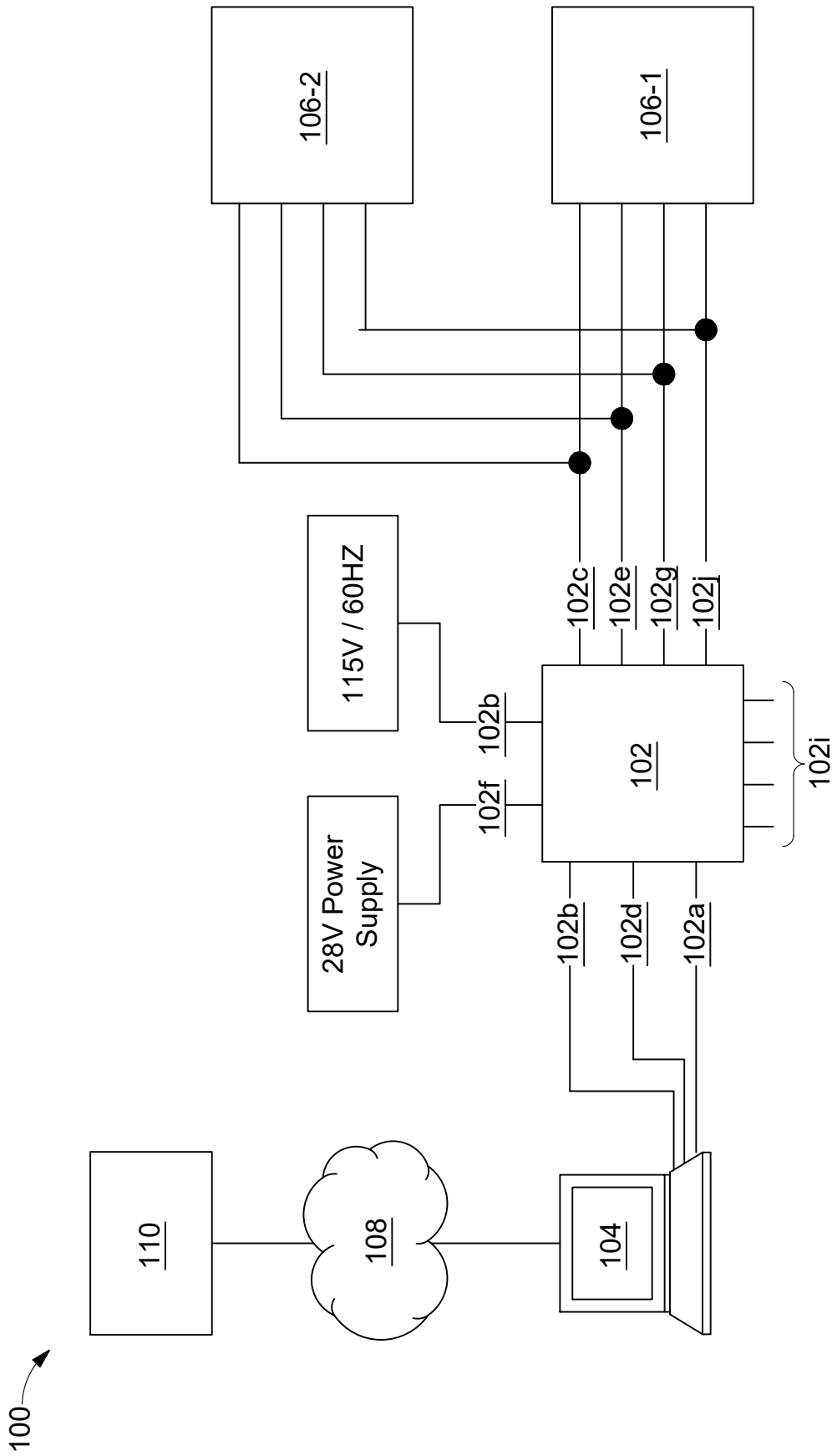

FIG. 1

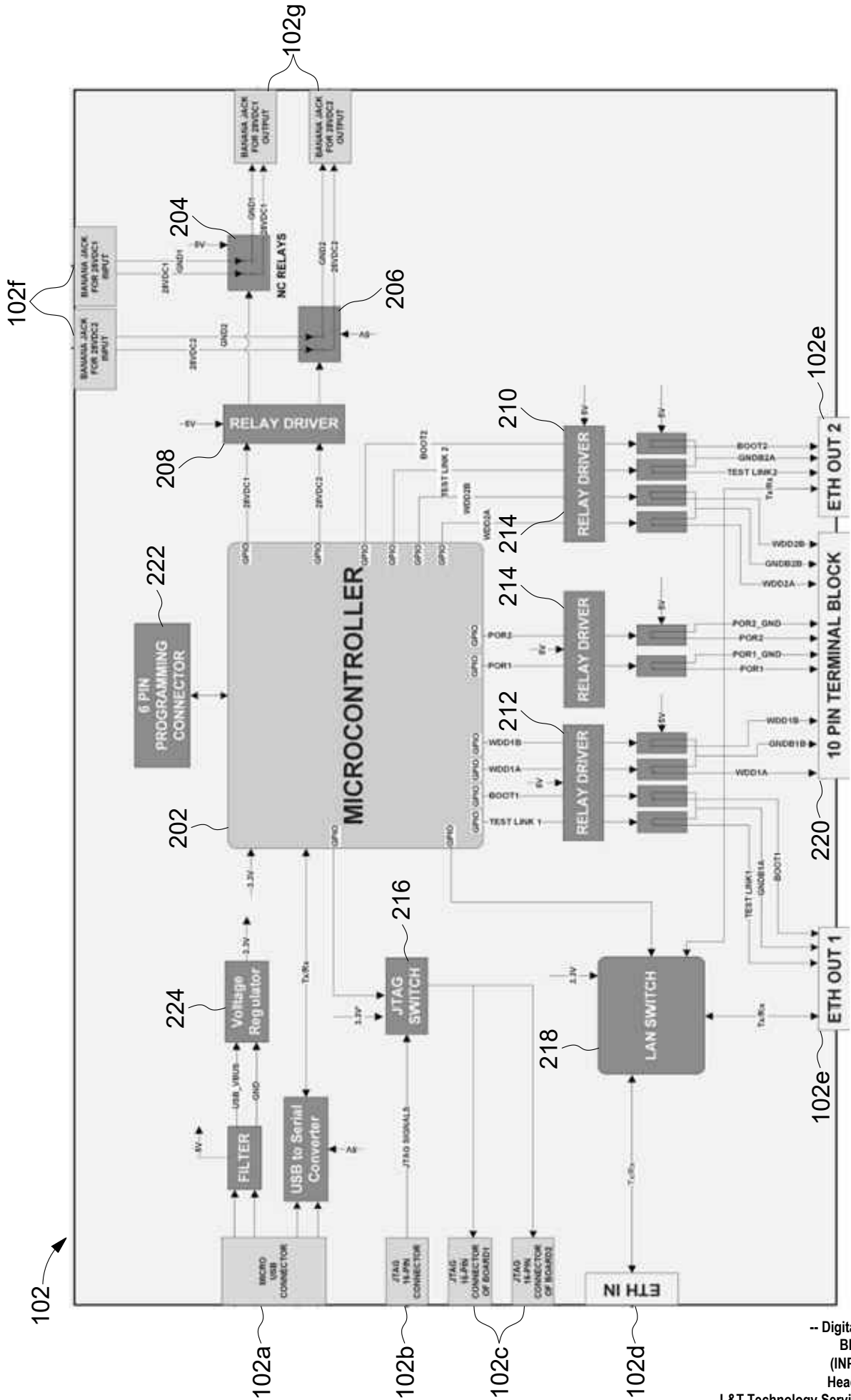

FIG. 2

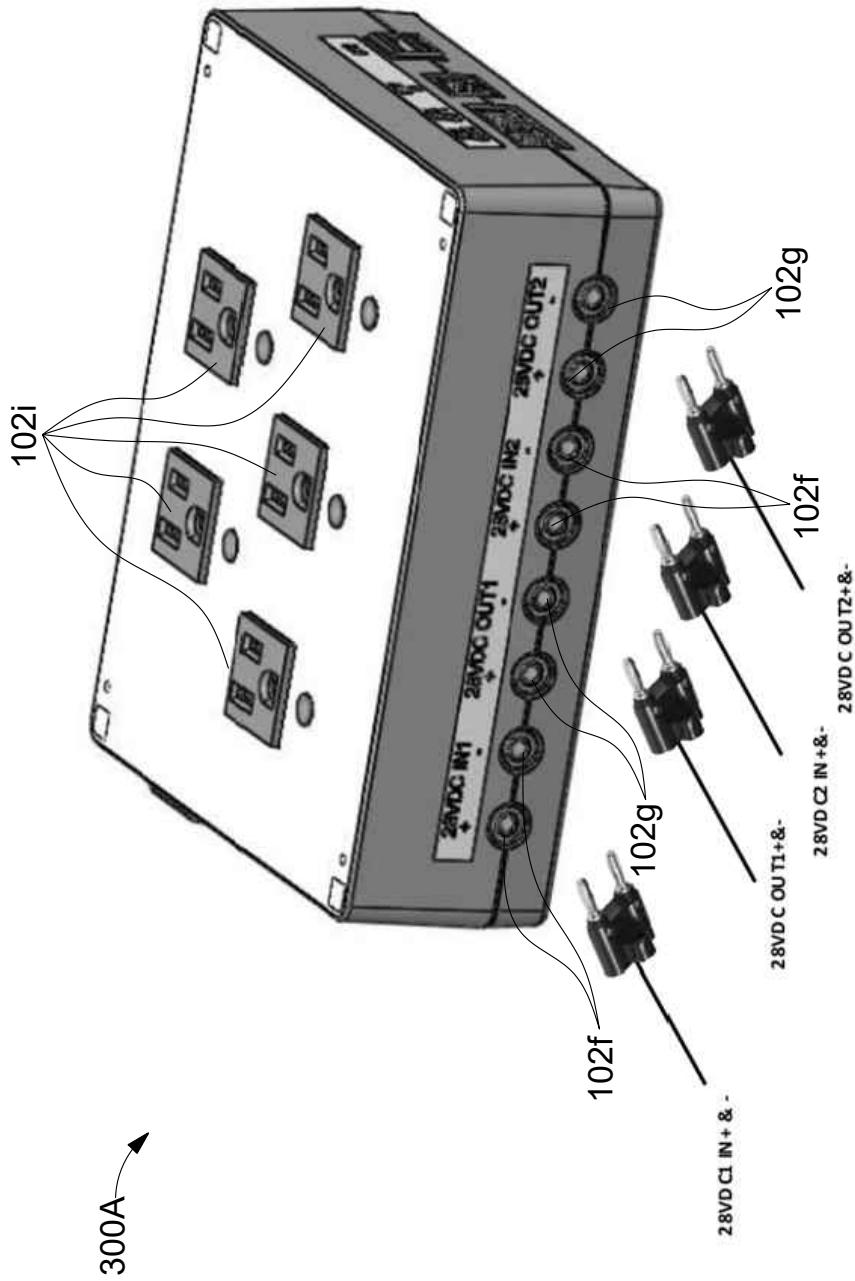

FIG. 3A

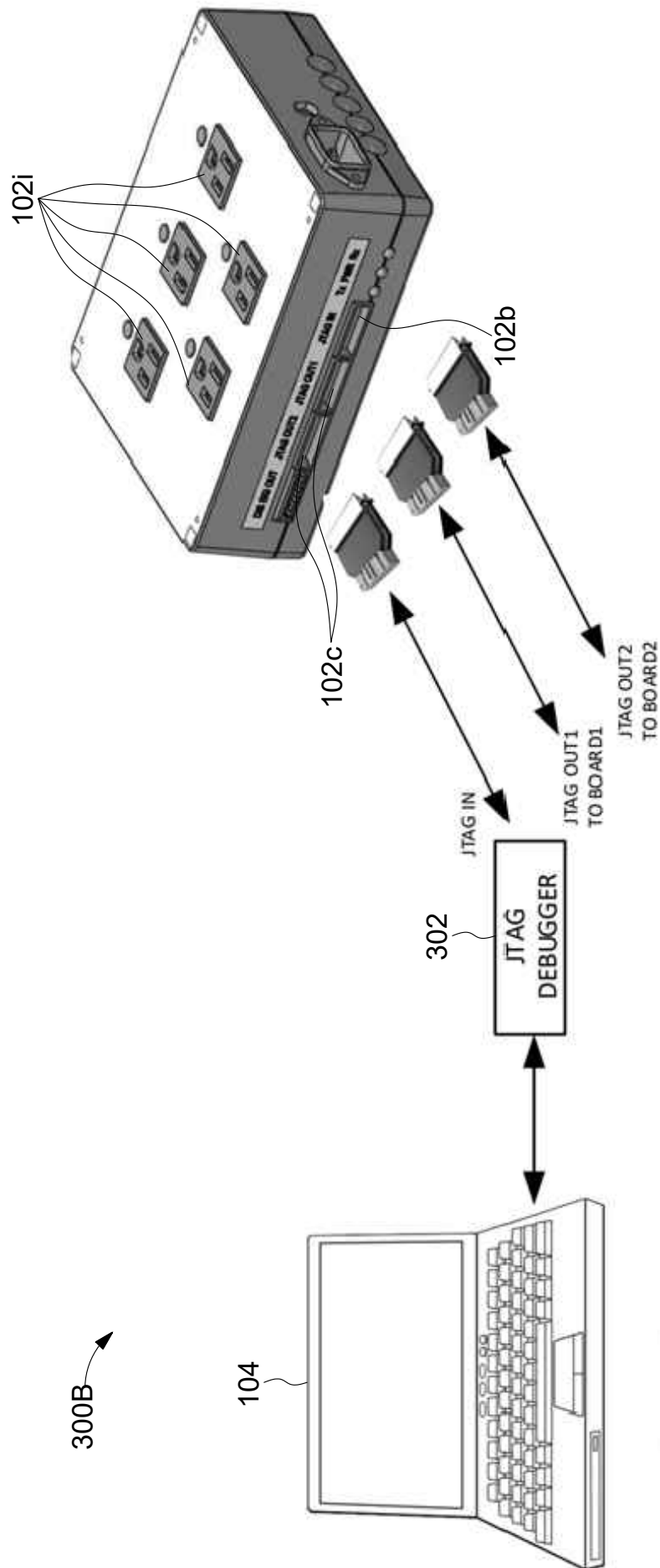

FIG. 3B

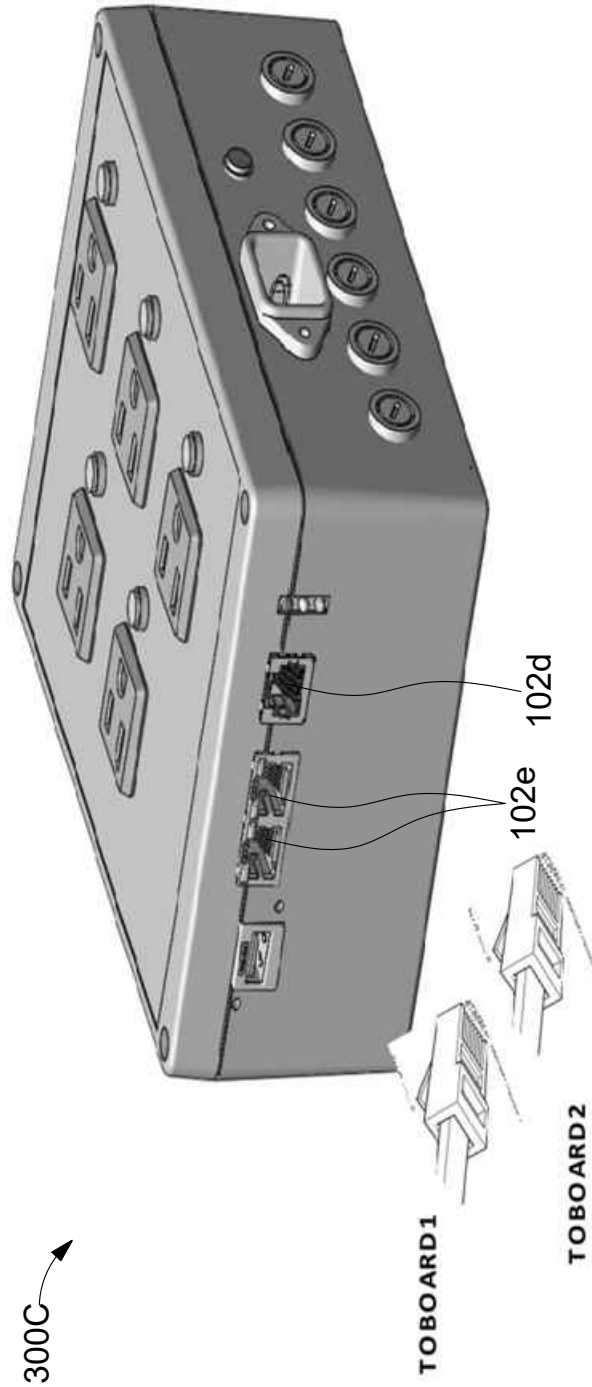

FIG. 3C

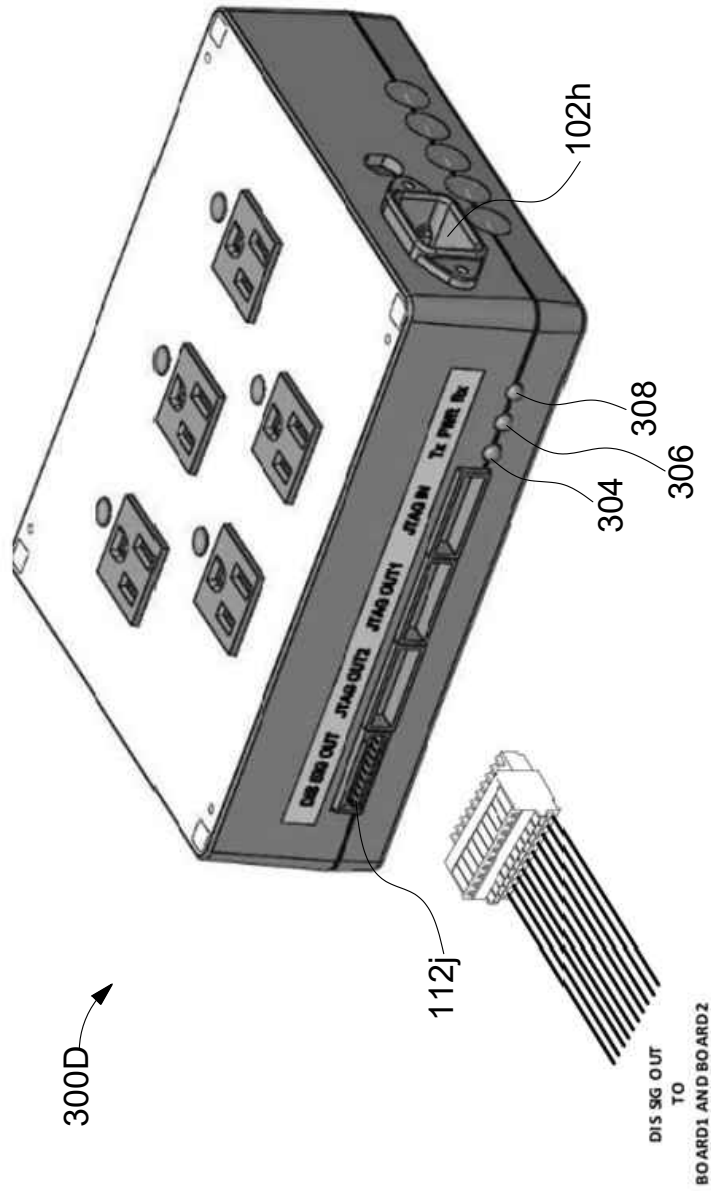

FIG. 3D

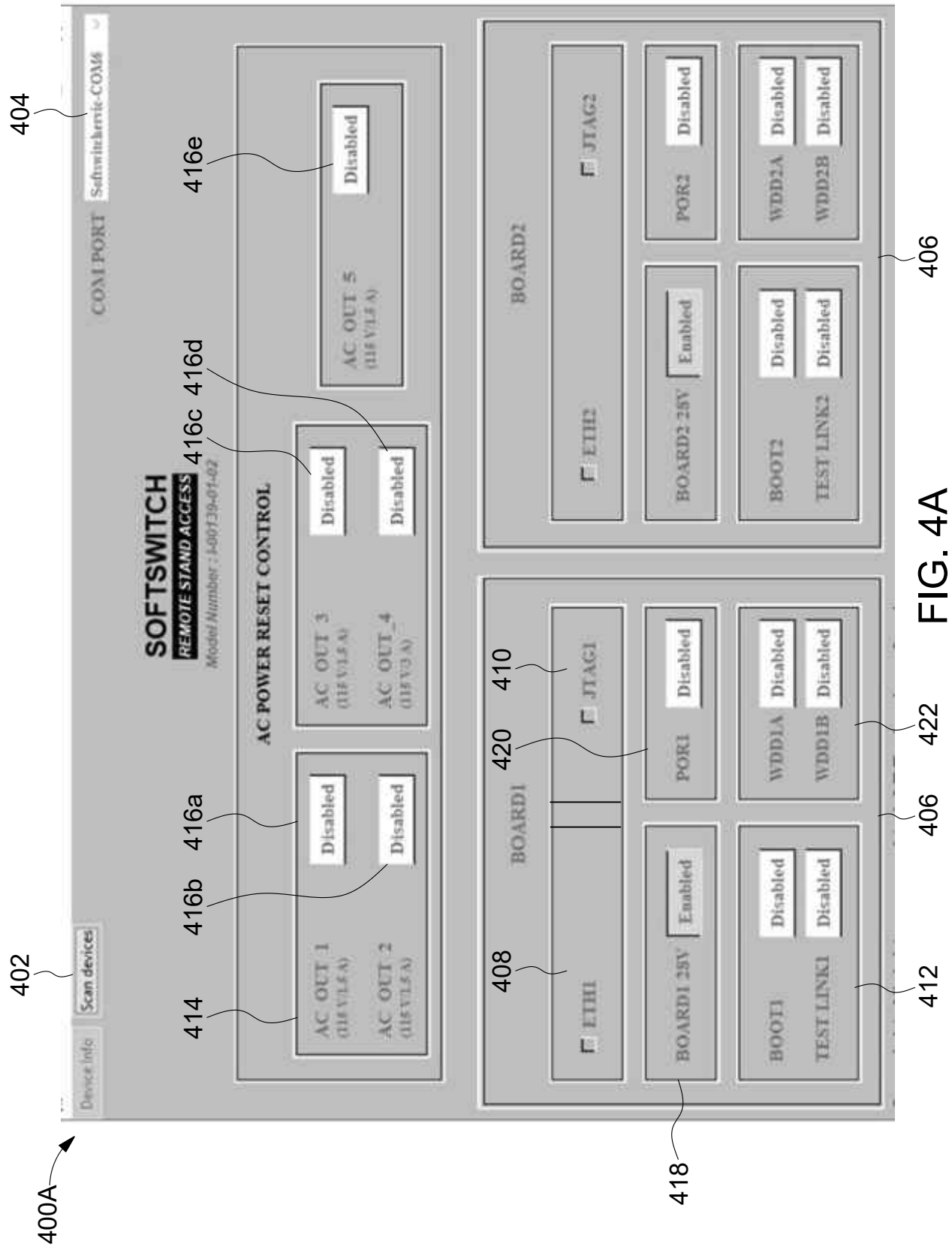

FIG. 4A

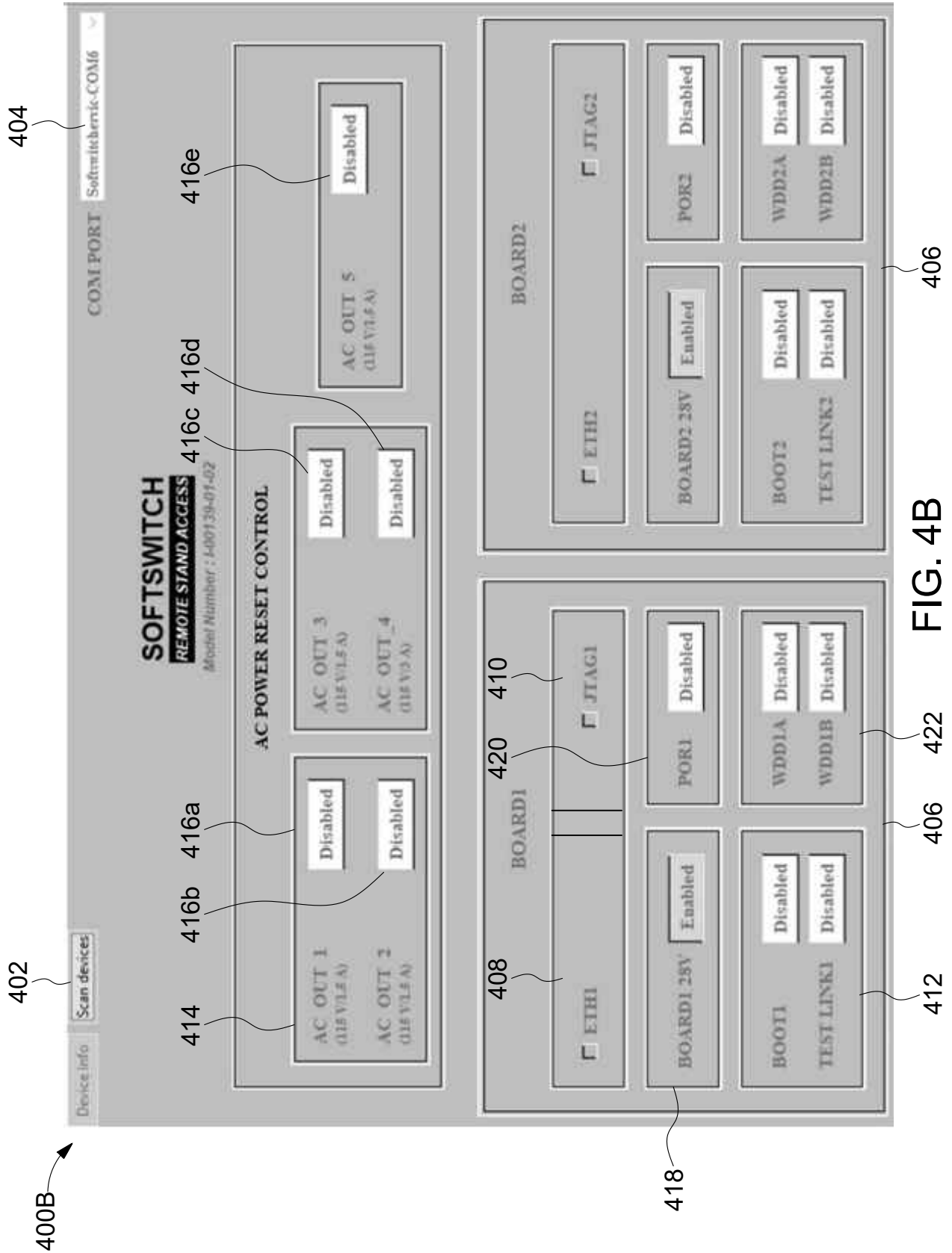

FIG. 4B

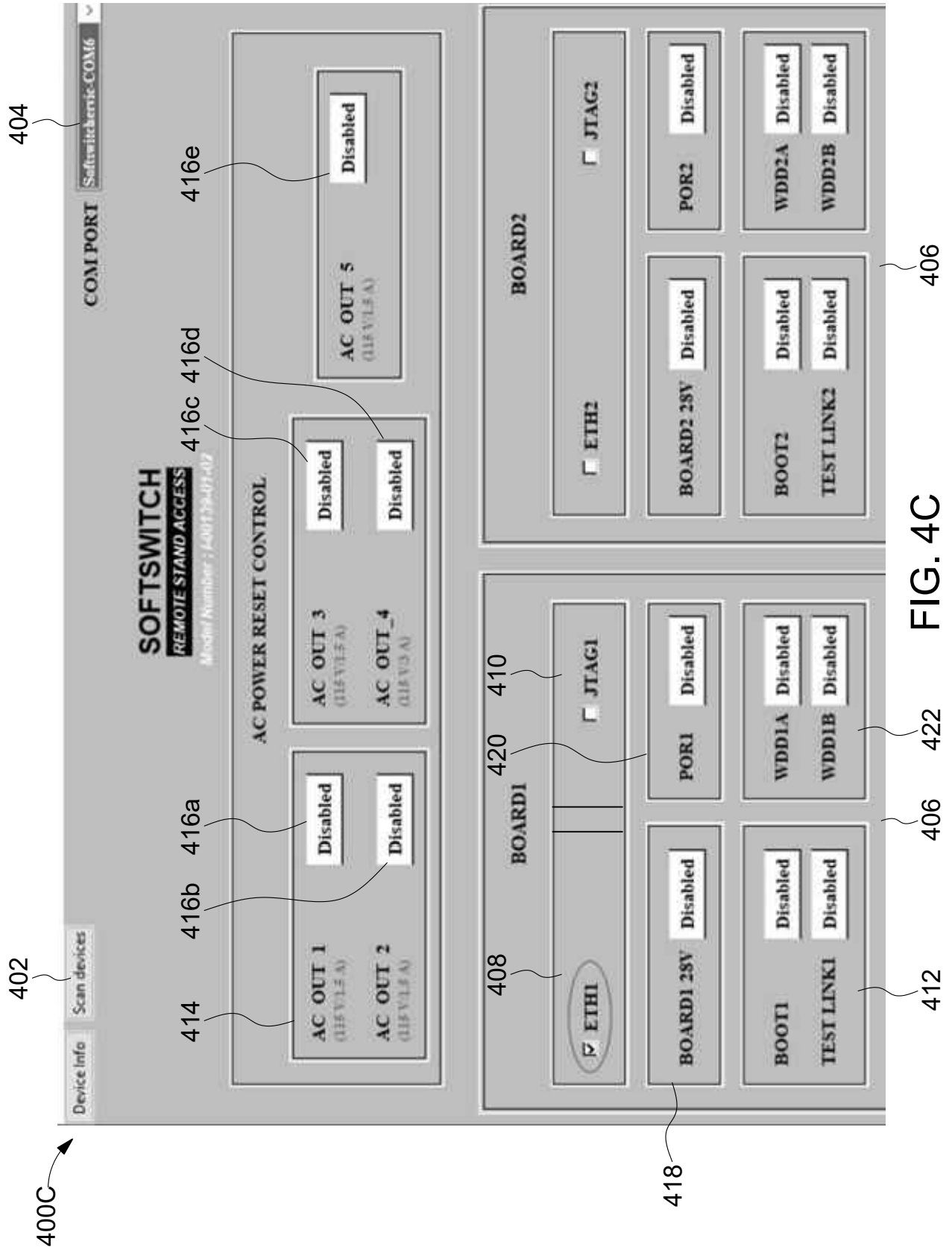

FIG. 4C

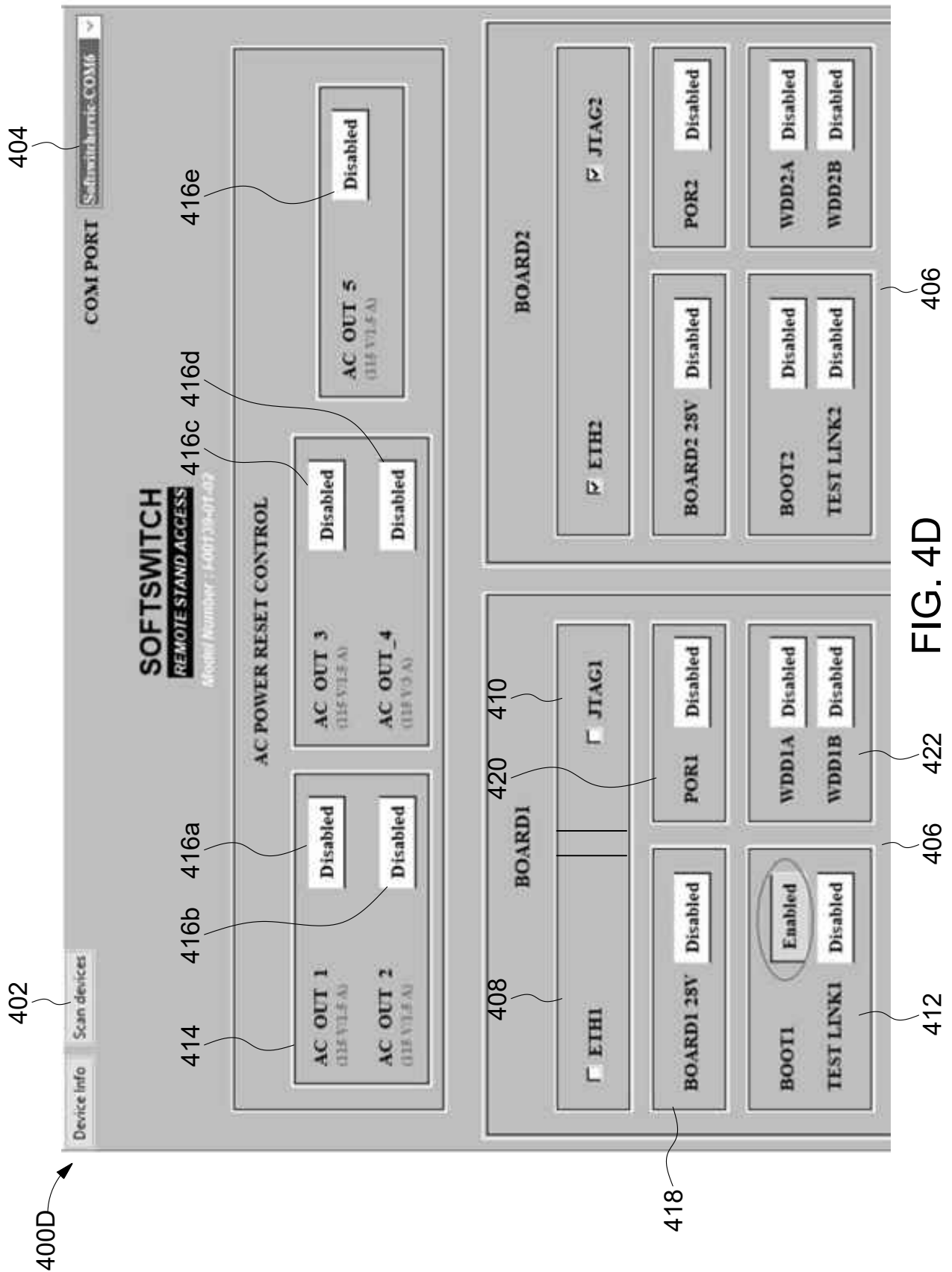

FIG. 4D

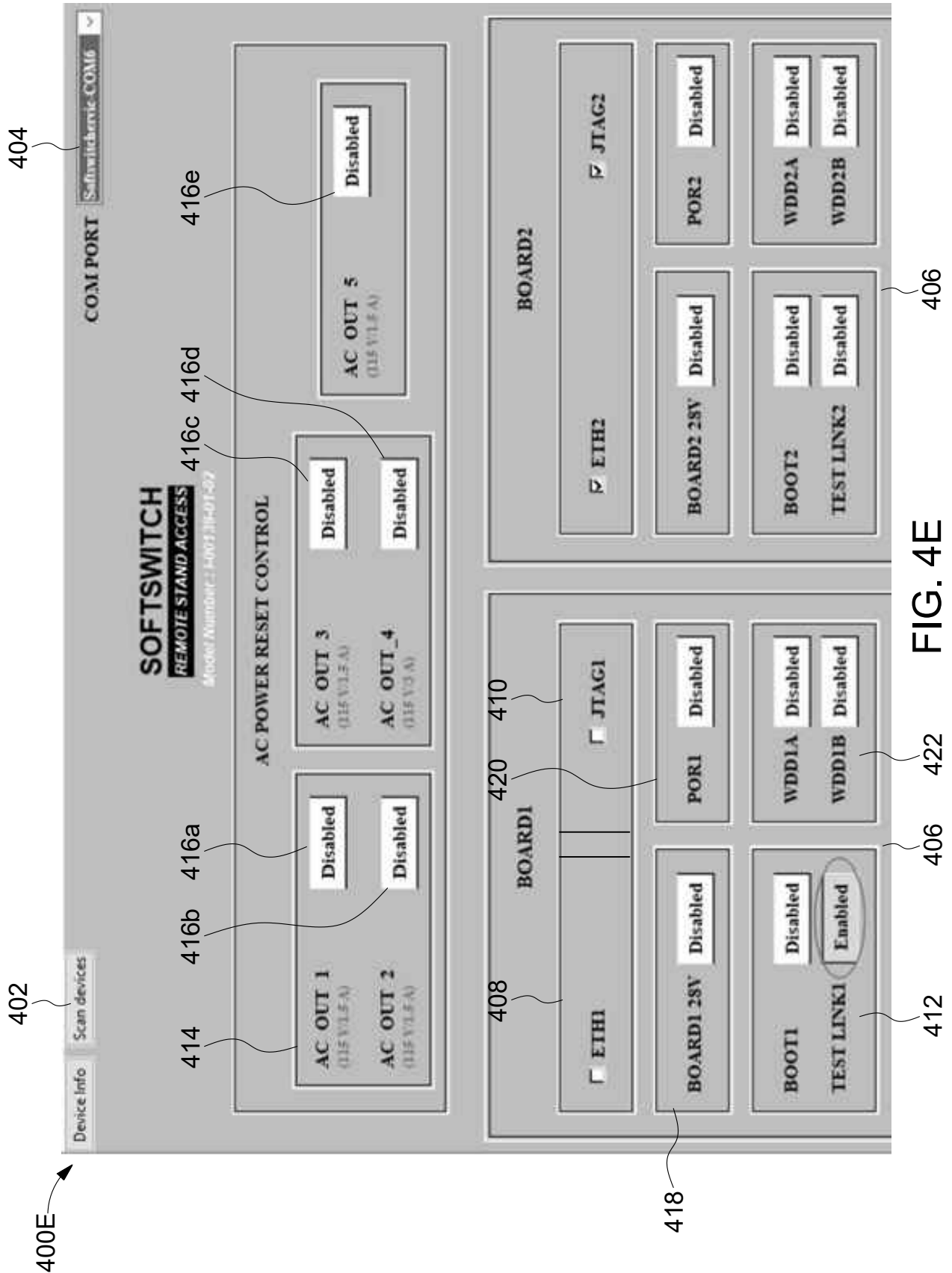

FIG. 4E

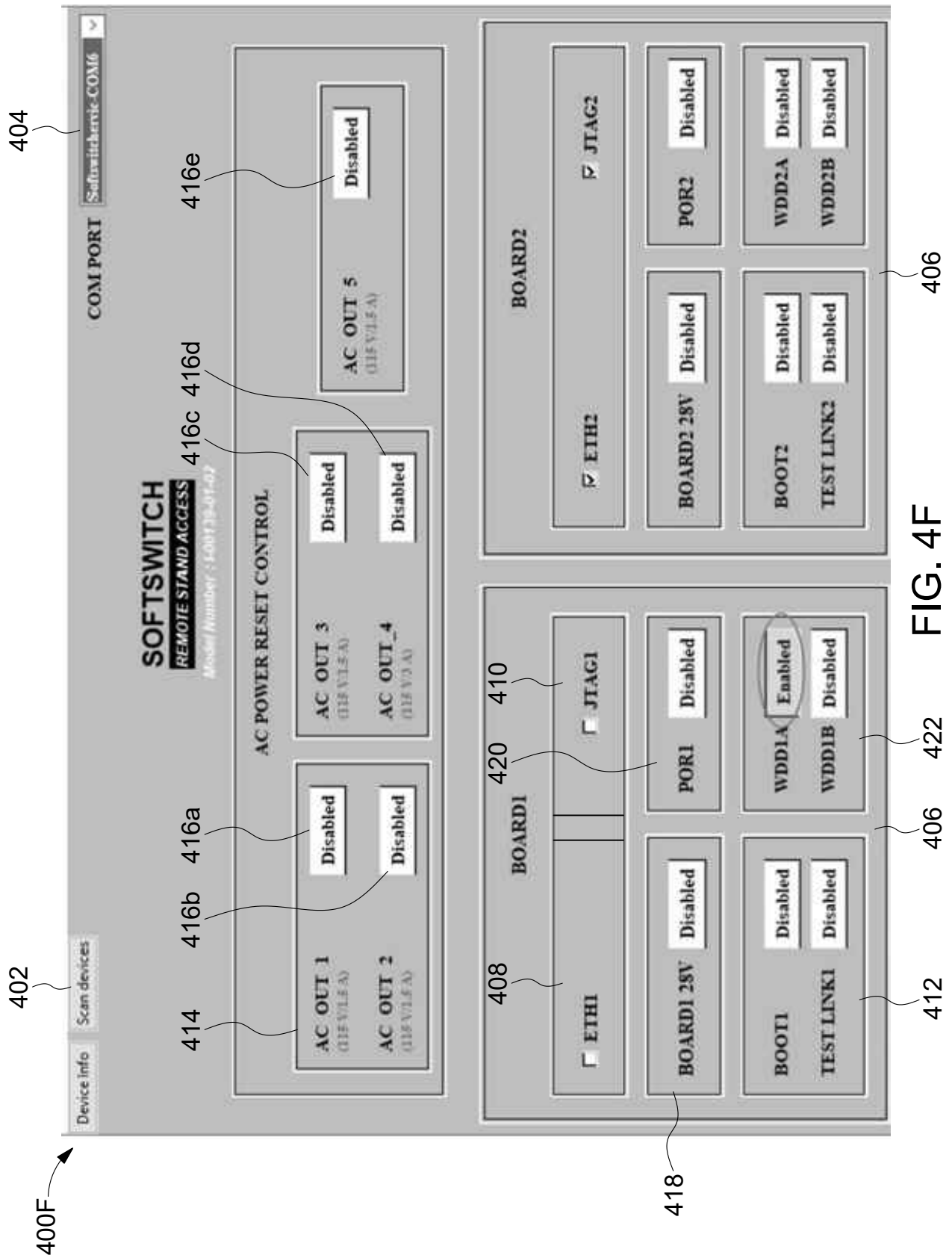

FIG. 4F

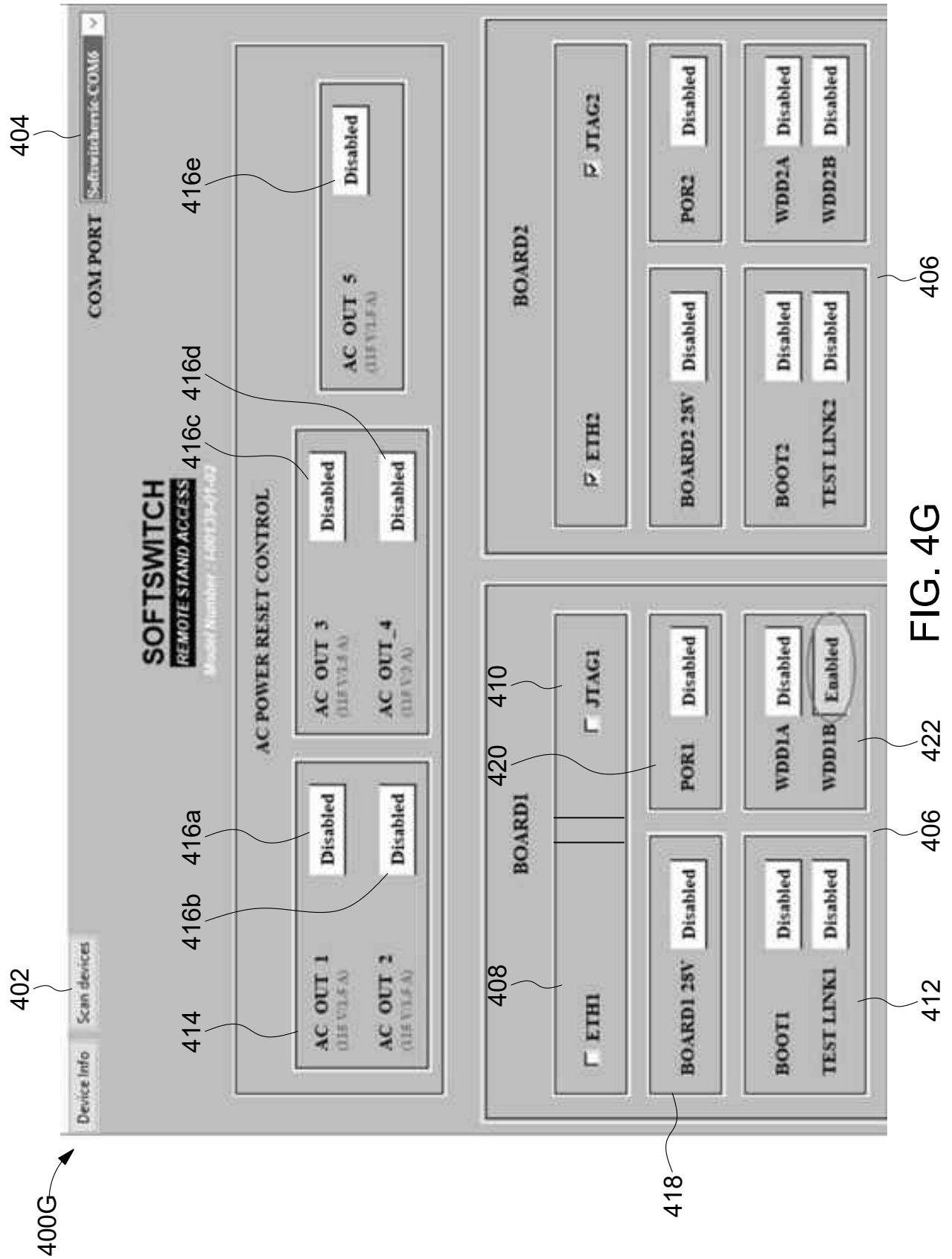

FIG. 4G

14/14

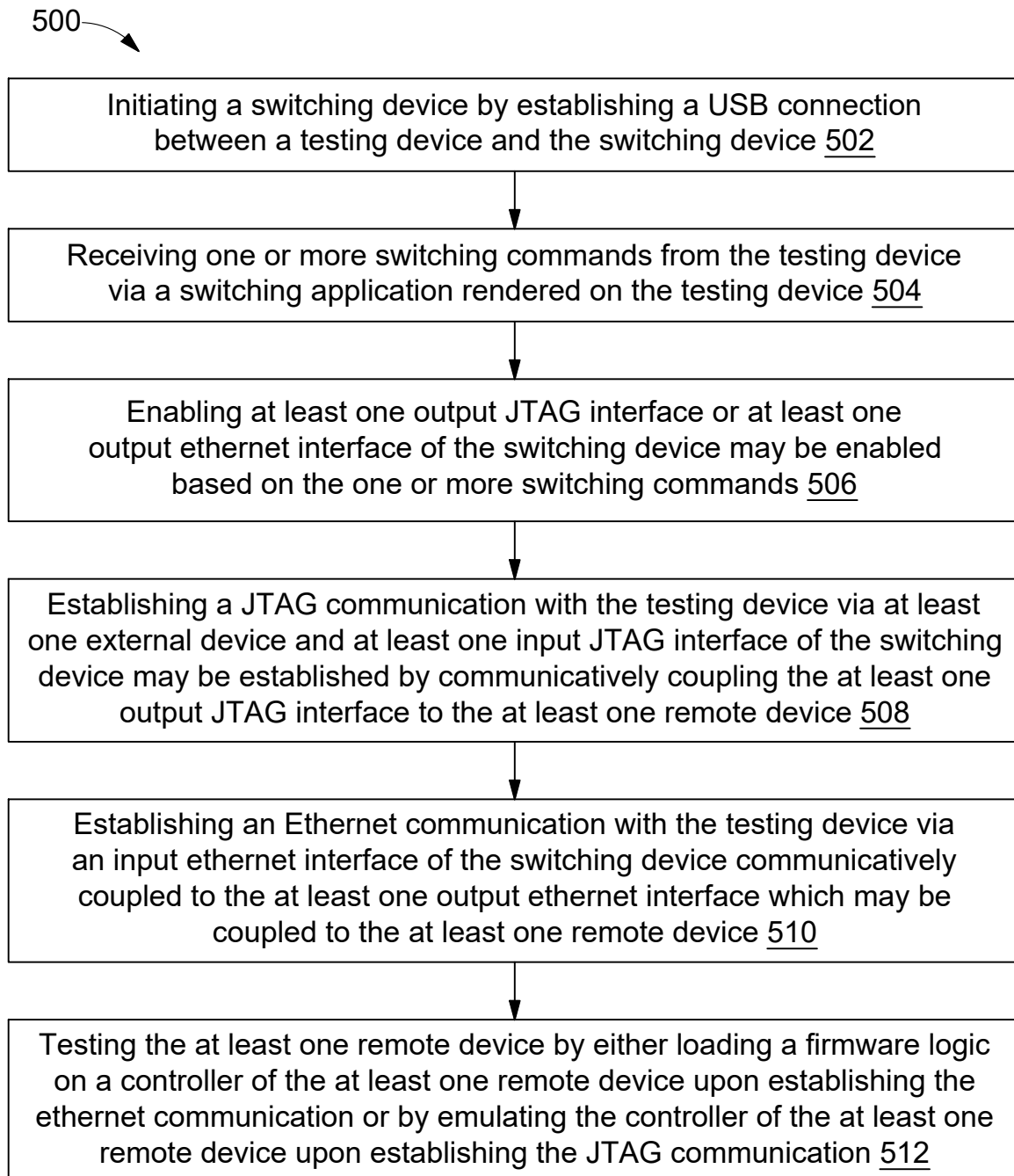

FIG. 5