

(12) Indian Patent Application

(21) Application Number: 202341060790

(22) Filing Date: 08/09/2023 (43) Publication Date: 14/03/2025

(71) Applicant(s): L&T TECHNOLOGY SERVICES LIMITED

(72) Inventor(s): Puttarangaswamy, Ranjith Gowda Rachenhalli
Mishra, Rahul Mani

(51) International Classifications: H01L 21/67 F01D 25/24 H04B 5/00 A61M 16/06 A61M 16/00

(54) Title: A DEVICE FOR HARVESTING

(57) Abstract: A device (100) for harvesting includes a casing (10) defining a hollow interior. A brush head (20) movably disposed within the hollow interior. An array of prongs (30) is mounted on the inner surface of the brush head (20) and extending there from into the hollow interior. The device additionally includes an actuation mechanism (35) disposed between the casing and the brush head. The device includes an actuator, mounted over the casing, and coupled with an actuation mechanism. The actuation of the actuator imparts a reciprocatory motion to the actuation mechanism and the brush head. Thus, the array of the prongs harvests the berries. Advantageously, harvesting by the device of present invention reduces time consumed without damaging the plant/tree from which the harvesting is done.

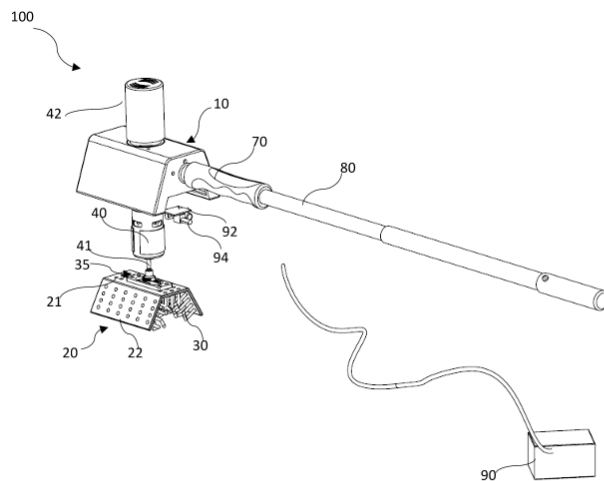

Figure 1

FORM 2

THE PATENTS ACT 1970
(39 OF 1970)
&
The Patent Rules, 2003

Complete Specification

(See Section 10 and Rule 13)

1. TITLE OF THE INVENTION

A DEVICE FOR HARVESTING

2. APPLICANT(S)

(a) NAME : **L&T TECHNOLOGY SERVICES LIMITED**

(b) NATIONALITY : **INDIAN**

(c) ADDRESS : **DLF IT SEZ Park, 2nd Floor – Block 3**

1/124, Mount Poonamallee Road,

Ramapuram, Chennai – 600 089,

INDIA.

3. PREAMBLE TO THE DESCRIPTION

COMPLETE

The following specification particularly describes the invention and the manner in which it is
to be performed

DESCRIPTION

Technical Field

[001] This disclosure relates generally to a device for harvesting, and more particularly to a device for harvesting fruits, vegetables, seeds and the like.

5

BACKGROUND

[002] Picking and harvesting of produce is a significant step in production. Harvesting is a complex and time-consuming process that has to be performed meticulously to ensure highest quality of produce is collected. Usually, collecting a produce depends on location, topography of plantation, and resources such as manpower or tools available. The produce may be fruits, 10 vegetables, or seeds. More particularly, for fruits such as berries it is pertinent to collect healthy and ripe berries to obtain high-quality produce. Conventionally, harvesting of berries is performed manually by hand picking or with conventional tools. In manual hand-picking process, the berries are hand-picked by a number of skilled people. This is also known as selective harvesting where only ripe berries are hand-picked individually. This manual hand-picking process is tedious and is 15 time-consuming. Moreover, this manual hand-picking requires only a skilled person to harvest.

[003] To address the limitations of the hand-picking, several types of tools and machines are used for plucking the berries at a faster rate. Typically, conventional tools include a means to hold the berries to be plucked from a stem or branch of a plant/tree. However, while plucking these berries by a pulling action, leaves, branches, and stem portion is completely stripping off, thereby 20 damaging the plant or tree. Also, a mixture of both ripe and under-ripe berries may be plucked in this process. Thus, the conventional tools lacks selectivity and as the berries, leaves, branch are damaged, leading to increased wastage and lack of productivity which is not desirable. Moreover, on larger and medium sized trees the branches bearing the fruits (berries) are at an elevation, it is difficult to pick the fruit using the conventional tools and tendency of the damaging the tree is 25 higher. Additionally, conventionally, large, and heavy tools are used to pick the berries, and such tools require continuous maintenance increasing production time and cost. Also, berries are quite delicate to handle and operating heavy tools and complex tools may damage the berry and plant/tree, resulting in increased wastage.

SUMMARY OF THE INVENTION

5 **[004]** In an embodiment, a device for harvesting is disclosed. The device may include a casing defining a hollow interior. The casing is formed by a pair of side walls having an upper end and a lower end. The casing includes a top wall joining the pair of side walls at the upper end. The casing further includes a pair of flanges, having each flange formed along the lower end of each of the pair of side walls. The pair of flanges extend inwardly into the hollow interior. The device includes a brush head, movably disposed within the hollow interior. The brush head is defined with a base having a pair of legs configured to form an inner surface and outer surface. Each leg of the pair of legs are slidably disposed over each of the pair of flanges. The device includes an array of prongs, which are mounted on the inner surface of the brush head and extends therefrom into the hollow interior. The device additionally includes an actuation mechanism disposed between the casing and the brush head. The actuation mechanism is configured to movably couple the brush head and the casing. Further, an actuator is mounted over the casing and coupled with the actuation mechanism. The actuation of the actuator imparts a reciprocatory motion to the actuation mechanism and the brush head to harvest.

10 **[005]** In an embodiment, the reciprocatory motion by the actuation mechanism and the brush head harvest at least one of fruits, vegetables, seeds received within the array of prongs.

15 **[006]** In an embodiment, the actuator is defined with a rotatable drive shaft extending into the hollow interior.

20 **[007]** In an embodiment, the actuation mechanism comprises a gear wheel, coupled to the drive shaft and a rack plate. The actuation mechanism also includes a rack plate is fixedly coupled to the brush head, defined with a slot to receive the gear wheel.

25 **[008]** In an embodiment, an inner surface of the slot of the rack plate is provided with a plurality of rack teeth configured to comparably mesh with the gear wheel.

[009] In an embodiment, the device comprises a primary handle fixedly coupled to the casing.

[010] In an embodiment, the device comprises a telescopic handle, coupled to the primary handle such that the telescopic handle is configured to extend and retract for accessibility to harvest.

30 **[011]** In an embodiment, the top wall of the casing is provided with a provision for passage of the rotatable drive shaft from the actuator into the hollow interior.

[012] In an embodiment, a front side of the casing includes an access opening for receiving the brush head within the hollow interior.

[013] In an embodiment, the device comprises a power source coupled to the actuator.

5 [014] In an embodiment, the device comprises a controller connected to the power source and the actuator. The controller is configured to trigger the actuator and to cause rotation of the drive shaft for imparting the reciprocatory motion to the actuation mechanism and the brush head.

[015] In an embodiment, the device comprises a switch connected to the controller, configured to trigger the actuator, and imparting the reciprocatory motion with a variable speed
10 depending on an extent the switch is pressed by an operator.

BRIEF DESCRIPTION OF THE DRAWINGS

[016] The accompanying drawings, which are incorporated in and constitute a part of this disclosure, illustrate exemplary embodiments and, together with the description, serve to explain the disclosed principles.

15 [017] **Figure 1** illustrates a perspective view of a device for harvesting, in accordance with an embodiment of the present disclosure;

[018] **Figure 2** illustrates an exploded view of the device for harvesting of Figure 1, in accordance with an embodiment of the present disclosure;

20 [019] **Figure 3** illustrates a sectional view of the device a telescopic arm in a retracted position, in accordance with an embodiment of the present disclosure;

[020] **Figure 4** illustrates a bottom view of the device with the telescopic arm in an extended position, in accordance with an embodiment of the present disclosure; and

[021] **Figure 5** illustrates a top view of an actuation mechanism, in accordance with an embodiment of the present disclosure.

25 **DETAILED DESCRIPTION OF THE DRAWINGS**

[022] Exemplary embodiments are described with reference to the accompanying drawings. Wherever convenient, the same reference numbers are used throughout the drawings to refer to the same or like parts. While examples and features of disclosed principles are described herein, modifications, adaptations, and other implementations are possible without departing from
30 the scope of the disclosed embodiments. It is intended that the following detailed description be

considered as exemplary only, with the true scope being indicated by the following claims. Additional illustrative embodiments are listed.

5 [023] Embodiments of the present disclosure disclose a device for harvesting fruits, vegetables, seeds, berries, specifically coffee berries [referred to as berries] and the like. The device is compact and can be carried to interiors of plantations and can be easily operated, thereby preventing potential damage to stems or leaves of plant or tree from which it is harvested. In an embodiment of the device, the device includes telescopic arm arrangement allowing for harvesting the berries grown at elevated portion of the tree/plant.

10 [024] The following paragraphs describe the present disclosure with reference to Figures.1 to 5. In the figures, the same element or elements which have similar functions are indicated by the same reference signs.

15 [025] Referring to **Figure 1** to **Figure 5** which are exemplary embodiments of the present disclosure illustrating a device for harvesting (100) [also referred as “device (100)”]. As will be understood, the device (100) may be configured for harvesting at least one of fruits, vegetable, seeds and the like.

20 [026] As shown in Figure. 1 and Figure. 2, the device (100) includes casing (10) defining therein a hollow interior. The hollow interior of the casing (10) is configured to support a brush head (20). The casing (10) is formed by a pair of side walls (11), a top wall (12) and a pair of flanges (13). Each wall of the pair side walls (11) has an upper end (11a) and a lower end (11b) as seen in figure 3. The top wall (12) is configured to join the pair of the side wall (11) at the upper end. More specifically, top wall (12) connects the upper end (11a) portions of the each side walls (11) facing opposite to each other to form a structure, defining a hollow interior. In an embodiment, the top wall (12) integrally connects the pair of side walls (10). However, this configuration of the top wall (12) may not be considered as a limitation, the top wall (12) may be removably connected to the pair of side walls (11) by any fastening means. Further, the pair of flanges (13) are defined such that each flange (13) is formed along the lower end (11b) of the each of the pair of side walls (11). Each flange (13) in the casing (10) is configured to extend inwardly into the hollow interior from the lower end (11b) of each of the pair of side walls (11). In an embodiment, the flange may extend towards each other from the lower end of the casing (10). In another embodiment, the pair of side walls (11) may be configured with an inclination and connected by the top wall (12). In this configuration, the pair of side walls (11) may be inclined with respect to each flange (13).

25
30

[027] The brush head (20) of the present disclosure is movably disposed within the hollow interior formed by the casing (10). The brush head (20) is defined with a base (21) and a pair of legs (22). The pair of legs (22) is connected by the base (21) to form the brush head (20) as seen in figure 1 and 2. This construction of base (21) and the pair of legs (22) is configured to form an inner surface and an outer surface of the brush head (20). The brush head (20) is disposed within the hollow interior of the casing (10) such that, each leg of pair of legs (22) is slidably disposed over each of the pair of flanges (13). More particularly, a bottom end portion of each leg (22) will be disposed over each flange (13), thereby abutting an upper surface of each flange (13). Accordingly, a top end portion of each leg of the pair of legs (22) will be connected by the base (21). As shown in Figure. 3, in an embodiment, a front side (14) of the casing (10) includes an access opening (14a) for receiving the brush head (20) within the hollow interior of the casing (10).

[028] The device (100) further comprises an array of prongs (30) mounted on the inner surface of the brush head (20). The array of prongs (30) mounted on the inner surface of the brush head (20) such that each prong (30) extends towards the hollow interior and away from the inner surface of the brush head (20). In an embodiment, each prong (30) may be arranged in an array or any required pattern and orientation. The array of prongs (30) may be defined as an elongated structure extending from the pair of legs (22). Further, a distal end of each prong (30) may be defined with a curved or bent structure to aid in clasping and gripping of the fruit, vegetable, or seed during harvesting. In an embodiment, each prong (30) of array of prongs (30) can have a configuration of snags, spikes, barbs, prickles, brush-teeth, bristles or the like. The arrangement of the array of prongs (30) on the inner surface of the brush head is used for securely accommodating the fruit, vegetable, or seed to be harvested. In a preferred embodiment, a plurality of berries is securely clasped by the brush head (20) via the array of prongs (30) to harvest.

[029] As shown in Figure. 1, the brush head (20) is operated by an actuation mechanism (35). The actuation mechanism (35) is disposed between the casing (10) and the brush head (20). The actuation mechanism (35) is movably coupled to the brush head (20) and the casing (10). Particularly, the actuation mechanism (35) is movably coupled to the base (21) of the brush head (20). Further, an actuator (40) is mounted over the casing (10) and is coupled with the actuation mechanism (35). The actuator (40) is enclosed within a housing (42). The actuator (40) includes a rotatable drive shaft (41) which is configured to couple with the actuation mechanism (35).

Referring to Figure 1 and Figure 3, the casing (10) is defined is provided with a provision (12a) on the top wall (12) for passage of the rotatable drive shaft (41) from the actuator (40) into the hollow interior to couple with the actuation mechanism disposed on the base (21) of the brush head (20). The provision (12a) may be defined as a through hole, aperture, slot and the like to accommodate the actuator (40) and the rotating shaft (41) to protrude and couple with actuation mechanism (35). As shown in Figure 3 and Figure 5, the actuation mechanism (35), comprises a gear wheel (50), which is coupled to the drive shaft (41) and a rack plate (60) which is fixedly coupled to the brush head (20). The brush head (20) is defined with a slot (61) to receive the gear wheel (50). Further, an inner surface of the slot (61) of the rack plate (60) is provided with a plurality of rack teeth (62) configured to comparably mesh with the gear wheel (50). As shown in Figure. 3, the rotatable drive shaft (41) is provided in the actuator (40), which extends into the hollow interior of the brush head (20) and couples with a shaft of the gear wheel (50) to be actuated. In an embodiment, the actuator (40) may be at least one of electric motor, hydraulic or pneumatic actuator.

[030] Referring Figure. 1, the actuator (40) is coupled to a power source (90). Further, the device (100) includes a controller (92) which is connected to the power source (90) and the actuator (40). The controller (92) is actuated by switching on the power source (90). The controller (92) is configured to trigger the actuator (40) and causes rotation of the drive shaft (41) for imparting the reciprocatory motion to the actuation mechanism (35) and the brush head (20).

[031] The rotatable drive shaft (41) provided in the actuator (40), imparts motion into the gear wheel (50). The gear wheel (50) thus rotating imparts motion to the plurality of rack teeth (62) of the rack plate (60) to which it is meshed. The rack plate (60) is imparted with the reciprocatory motion due the presence of slot (61) of the rack plate (60). As the rack plate (60) is fixedly coupled to the brush head (20), the array of prongs (30) is moved with the reciprocatory motion which leads to harvesting of the berries. Thus, the rotatable drive shaft (41) imparts a reciprocatory motion to the actuation mechanism (35) and the brush head (20) to harvest. The reciprocatory motion thus induced by the actuation mechanism (35) into the brush head (20) facilitates harvesting of at least one of fruits, vegetables, seeds, berries or the like, are received within the array of prongs (30).

[032] A switch (94) is provided to be operable by the user/operator is configured to trigger the actuator (40) and impart the motion with a variable speed. In an embodiment, the switch

(94) is coupled to the controller (92). Further the switch (94) may be provided to trigger the actuator (40) for controlling variable speeds of the rotation of the drive shaft (41). Thus, controlling the speed of the reciprocatory motion of the actuation mechanism (35) and the brush head (20). The switch (94) may be switched between the three modes of operation like, ON/OFF and controlled speed conditions. In an embodiment, in an ON condition the switch (94) actuates the actuator (40) to rotate the drive shaft (41), which imparts the reciprocatory motion to the actuation mechanism (35) and the brush head (20). Likewise, in an OFF condition the actuator (40) stops the rotation of the drive shaft (41) by disconnecting the power source (90). In an embodiment, in the controlled speed condition, the switch (94) may be operated to induce different speeds of rotation to the drive shaft (41), thereby controlling the speed of reciprocatory motion of the actuation mechanism (35) and the brush head (20). The ON/OFF and controlled speed of actuation allows the operator to conveniently use the device (100) as required.

[033] Referring to Figure. 1 and Figure. 4, the device (100) for harvesting comprises a primary handle (70) fixedly coupled to the casing (10). In an embodiment of the present disclosure, the device (100) comprises a telescopic handle (80) which is coupled to the primary handle (70). The telescopic handle (80) is configured to be in an extended position and retracted position. The telescopic handle (80) is also configured to be in any position between extended position or retracted position for accessibility to harvest the berries at different elevations of the plants or trees. The telescopic handle (80), when in completely retracted position is accommodated within the primary handle (70) as seen in figure 3.

[034] The operator or the user of the device (100), holds the primary handle (70) of the device (100) to harvest the fruits, vegetables, seeds, berries, coffee berries and the like are approachable to the operator or the user. The operator can use the telescopic handle (80) to harvest, to reach different heights of the plants or trees which are not approachable by the operator or the user. The telescopic handle (80) is connected to the primary handle (70) which is in turn connected to the casing (10) of the device. Further, the actuator (40) is actuated by switching on the power source (90), and the operator can control the operation of the actuator (40), by triggering the controller (92) which is connected to the power source (90). The device (100) is held on the desired location where the berries are to be harvested and the controller (92) is triggered by the operator. Thus, the actuator (40) is made to operate by rotating the rotatable drive shaft (41) provided in the actuator (40). The rotatable drive shaft (41) imparts motion into the gear wheel (50). The rotation

of the gear wheel (50) thus moves to the plurality of rack teeth (62) of the rack plate (60) to which it is meshed. Thus, the rack plate (60) is imparted with the reciprocatory motion due the presence of slot (61) of the rack plate (60). As the rack plate (60) is fixedly coupled to the brush head (20), the brush head (20) and the array of prongs (30) are moved with the reciprocatory motion which leads to harvesting and collecting of the berries. In an embodiment, the berries can be collected in a collection bin provided proximal or below a position of the device during harvesting.

[035] The above subject matter discloses a device (100) which provides ease of handling and without a need for skilled person to operate. Further, device (100) is compact and can be carried to interiors of plantations and can be easily operated. The device (100) eliminates the need of manual plucking and thus reduces the time consumed for harvesting. The device also eliminates strip harvesting process, preventing potential damage to the stems or leaves of the plant or tree from which it is harvested. The device (100) includes telescopic arm arrangement which can reach different heights of the plant for harvesting the berries.

[036] It is intended that the disclosure and examples be considered as exemplary only, with a true scope of disclosed embodiments being indicated by the following claims.

WE CLAIM:

1. A device (100) for harvesting, comprising:

a casing (10) defining therein a hollow interior, wherein the casing (10) is formed by:

a pair of side walls (11) having an upper end (11a) and a lower end (11b);

a top wall (12) joining the pair of side walls (11) at the upper end (11a); and

a pair of flanges (13), having each flange formed along the lower end (11b) of each of the pair of side walls (11), wherein the pair of flanges (13) extending inwardly into the hollow interior;

a brush head (20), movably disposed within the hollow interior, defined with a base (21) having a pair of legs (22) configured to form an inner surface and outer surface, wherein each leg of the pair of legs (22) are slidably disposed over each of the pair of flanges (13);

an array of prongs (30), mounted on the inner surface of the brush head (20), and extending therefrom into the hollow interior;

an actuation mechanism (35) disposed between the casing (10) and the brush head (20), wherein the actuation mechanism (35) is configured to movably couple the brush head (20) and the casing (10); and

an actuator (40), mounted over the casing (10) and coupled with the actuation mechanism (35),

wherein actuation of the actuator (40) imparts a reciprocatory motion to the actuation mechanism (35) and the brush head (20) to harvest.

2. The device (100) as claimed in claim 1, wherein the reciprocatory motion by the actuation mechanism (35) and the brush head (20) harvest at least one of fruits, vegetables, seeds received within the array of prongs (30).

3. The device (100) as claimed in claim 1, wherein the actuator (40) is defined with a rotatable drive shaft (41) extending into the hollow interior.
4. The device (100) as claimed in claim 3, wherein the actuation mechanism (35) comprises;

a gear wheel (50), coupled to the drive shaft (41); and

a rack plate (60), fixedly coupled to the brush head (20), defined with a slot (61) to receive the gear wheel (50).
5. The device (100) as claimed in claim 4, wherein an inner surface of the slot (61) of the rack plate (60) is provided with a plurality of rack teeth (62) configured to comparably mesh with the gear wheel (50).
6. The device (100) as claimed in claim 1, comprises a primary handle (70) fixedly coupled to the casing (10).
7. The device (100) as claimed in claim 6, comprises a telescopic handle (80), coupled to the primary handle (70), configured to extend, and retract for accessibility to harvest.
8. The device (100) as claimed in claim 4, wherein the top wall (12) of the casing (10) is provided with a provision (12a) for passage of the rotatable drive shaft (41) from the actuator (40) into the hollow interior.
9. The device (100) as claimed in claim 1, wherein a front side (14) of the casing (10) includes an access opening (14a) for receiving the brush head (20) within the hollow interior.
10. The device (100) as claimed in claim 1, comprises a power source (90) coupled to the actuator (40).
11. The device (100) as claimed in claim 10, comprises a controller (92) connected to the power source (90) and the actuator (40), wherein the controller (92) is configured to trigger the actuator (40) and to cause rotation of the drive shaft (41) for imparting the reciprocatory motion to the actuation mechanism (35) and the brush head (20).

12. The device (100) as claimed in claim 11, comprises a switch (94) connected to the controller (92), configured to trigger the actuator (40), and imparting the reciprocatory motion with a variable speed depending on an extent the switch (94) is pressed by an operator.

Dated this 8th day of September 2023

-- Digitally Signed--

Bhanu Prasad

(INPA No: **3253**)

Head, IPR Dept.,

L&T Technology Services Limited,

DLF 3rd Block, 2nd Floor,

Manapakkam, Chennai - 600089.

ABSTRACT

A DEVICE FOR HARVESTING

A device (100) for harvesting includes a casing (10) defining a hollow interior. A brush head (20) movably disposed within the hollow interior. An array of prongs (30) is mounted on the inner surface of the brush head (20) and extending there from into the hollow interior. The device additionally includes an actuation mechanism (35) disposed between the casing and the brush head. The device includes an actuator, mounted over the casing, and coupled with an actuation mechanism. The actuation of the actuator imparts a reciprocatory motion to the actuation mechanism and the brush head. Thus, the array of the prongs harvests the berries. Advantageously, harvesting by the device of present invention reduces time consumed without damaging the plant/tree from which the harvesting is done.

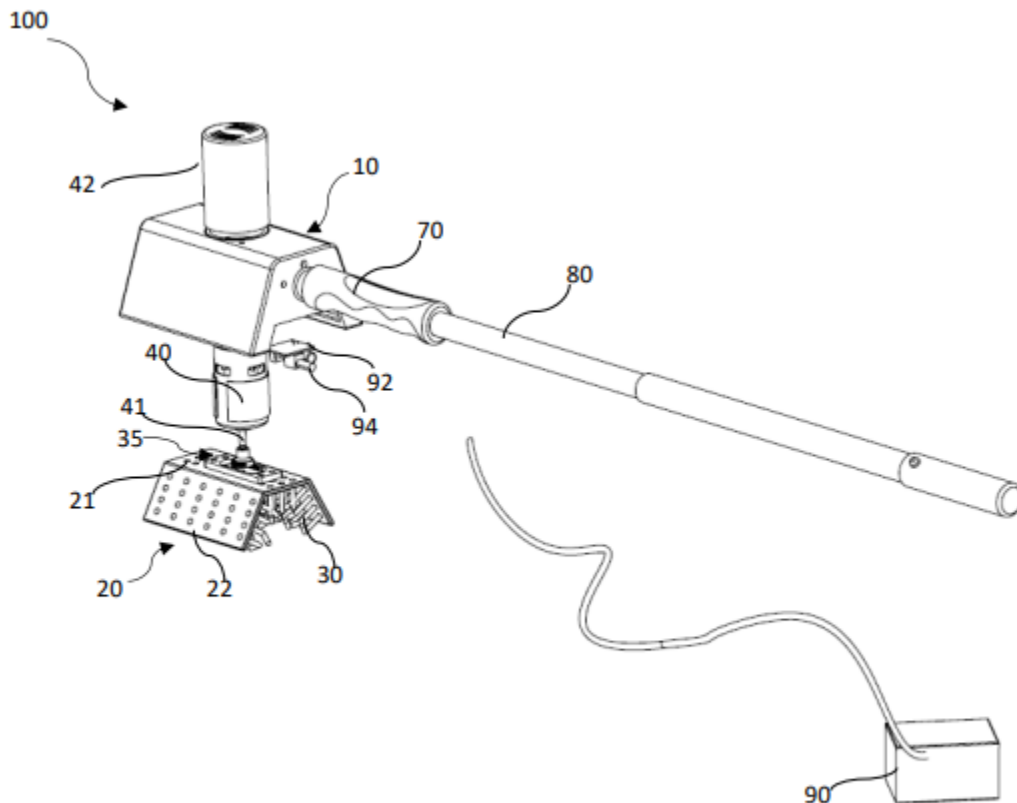

Figure 1

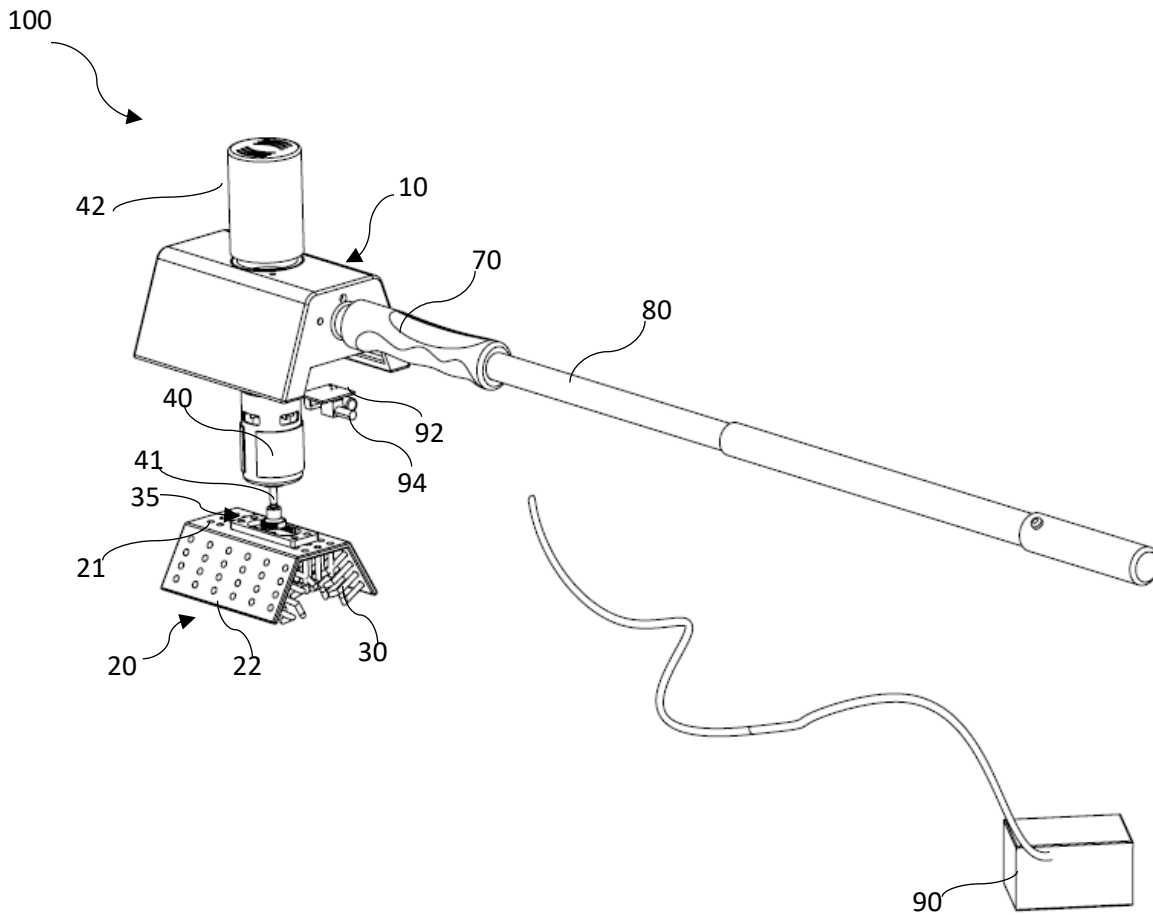

Figure 1

-- Digitally Signed--
Bhanu Prasad
(INPA No: 3253)
Head, IPR Dept.,
L&T Technology Services Limited,
DLF 3rd Block, 2nd Floor,
Manapakkam, Chennai - 600089.

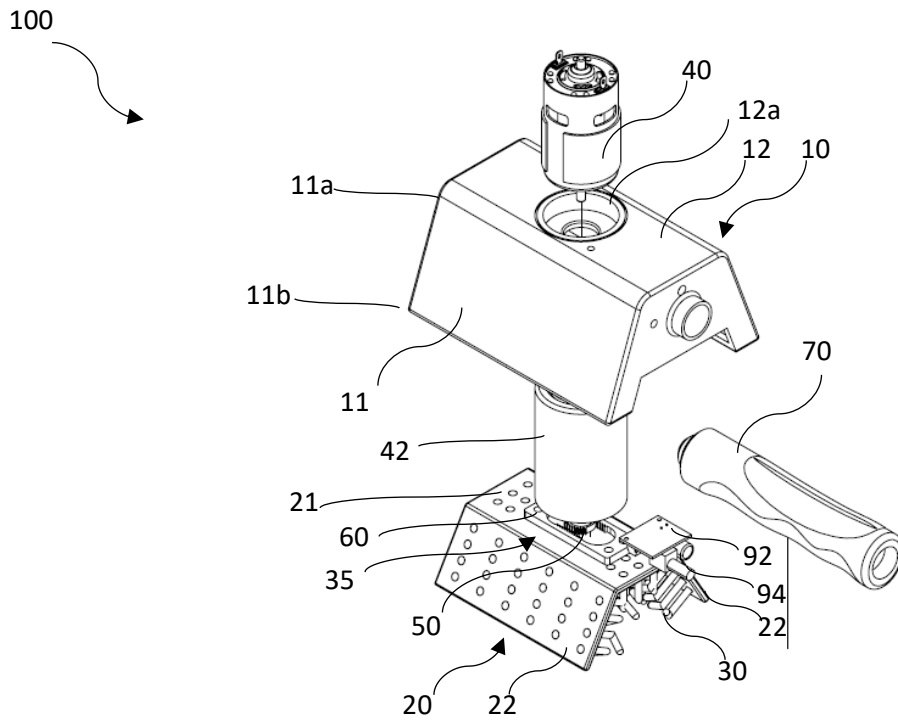

Figure 2

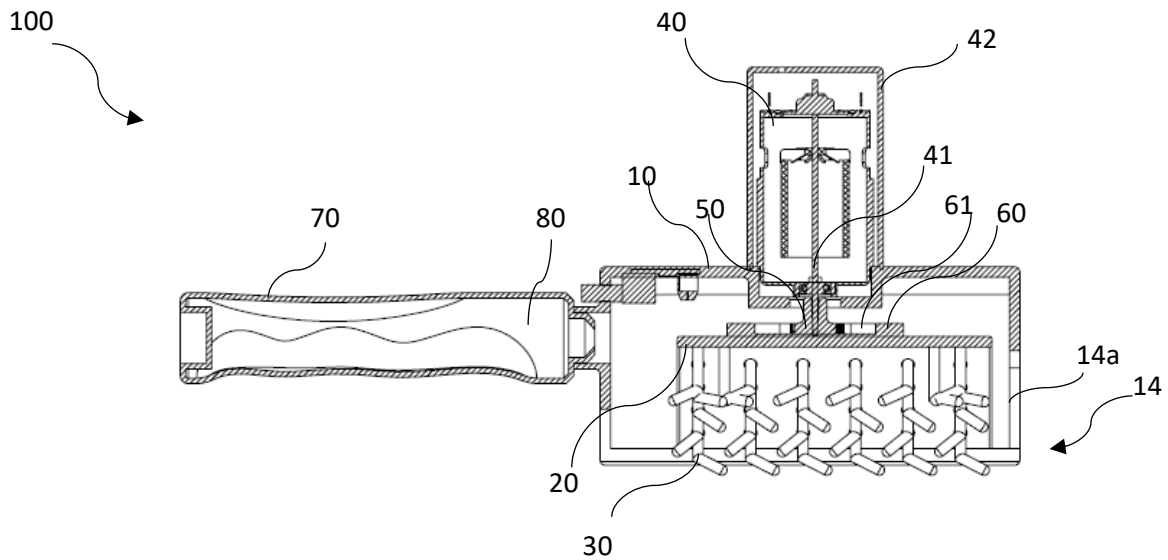

Figure 3

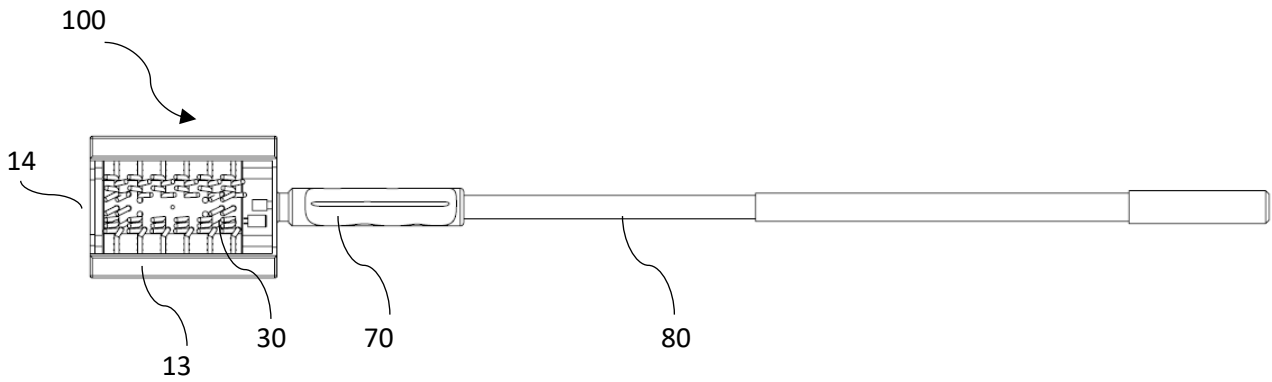

Figure 4

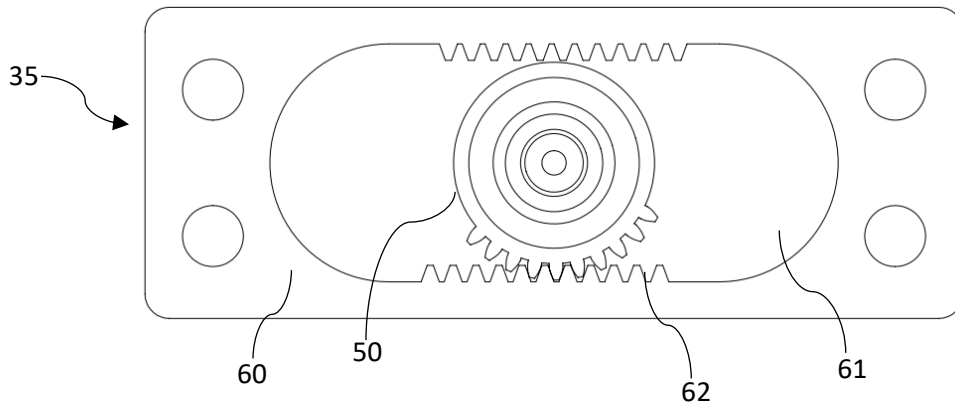

Figure 5