

(12) Indian Patent Application

(21) Application Number: 202341060791

(22) Filing Date: 08/09/2023 (43) Publication Date: 14/03/2025

(71) Applicant(s): L&T TECHNOLOGY SERVICES LIMITED

(72) Inventor(s): Rangachar, Narasimha Moorthy Vijaya Raghavan
Takoor, Sangeetha

(51) International Classifications: B41J 2/14 H01Q 1/38 H01L 41/04 H01L 41/09 F16K 31/00

(54) Title: PIEZOELECTRIC DRIVE CIRCUITRY AND SYSTEM AND METHOD THEREOF

(57) Abstract: A method and system of piezoelectric drive circuitry (100) is disclosed. The method includes receiving a fluidic mixture from an enlist of a channel. Vibration is applied along the length of the channel using a piezoelectric actuator (108) operating at a predefined frequency. The first liquid is received from at least one outlet (304, 308). The piezoelectric actuator (108) is configured to vibrate at a predefined frequency by a wave signal is generated at the predefined frequency, a first PWM signal and a second PWM signal is generated based on the square wave signal, the first PWM signal and the second PWM signal are alternatively applied to the piezoelectric actuator (108).

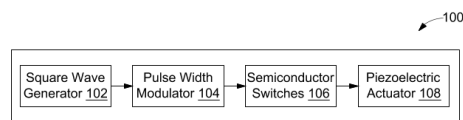

FIG. 1

FORM 2

THE PATENTS ACT 1970
(39 OF 1970)

&

The Patent Rules, 2003

Complete Specification

(See Section 10 and Rule 13)

1. TITLE OF THE INVENTION

PIEZOELECTRIC DRIVE CIRCUITRY AND SYSTEM AND METHOD THEREOF

2. APPLICANT(S)

(a) NAME : **L&T TECHNOLOGY SERVICES LIMITED**

(b) NATIONALITY : **INDIAN**

(c) ADDRESS : DLF IT SEZ Park, 2nd Floor – Block 3
1/124, Mount Poonamallee Road,
Ramapuram, Chennai – 600 089,
INDIA.

3. PREAMBLE TO THE DESCRIPTION

COMPLETE

The following specification particularly describes the invention and the manner in which it is
to be performed

DESCRIPTION

Technical Field

5 [001] This disclosure relates generally to piezoelectric elements, and more particularly relates to piezoelectric drive circuitry and system and method thereof.

BACKGROUND

10 [002] Piezoelectric material is a dielectric material that exhibits mechanical deformation under application of an electric field, and vice-versa. Due to this unique property, piezoelectric materials are widely utilized for interconversion of mechanical energy and electrical energy in an array of applications related to space exploration, cryogenic technology advancements, and various medical treatment methodologies. One of such medical treatment methodologies may require separation of plasma (liquid part of blood) and blood corpuscles (solid part of blood) for which conventionally centrifugal force-based separation techniques are utilized. Such techniques rely on rotation of a centrifuge comprising a blood sample at a high speed which may lead to separation of plasma due to a difference of its mass density from that of the blood corpuscles.

15 [003] This is a simple technique for plasma separation, however there are a few existing drawbacks which include a challenge of governing/controlling the rotational speed of the centrifuge. There is a possibility of hemolysis or structural damage of the blood corpuscles in case of a high rotational speed of the centrifuge, and an insufficient separation of plasma in case of a relatively lower rotation speed of the centrifuge.

20 [004] To this end, the piezoelectric materials may be utilized for providing vibrations to the blood sample at a frequency sufficient to allow separation of the plasma. There have been many innovations for generation of the vibrations in the piezoelectric materials, however constraints regarding generation of vibrations at a variable, and a relatively higher frequency, besides operational cost of such innovations could not be addressed satisfactorily.

25 [005] Therefore, there is a requirement for a robust, and compact piezoelectric based system and method thereof.

SUMMARY OF THE INVENTION

[006] In an embodiment, a piezoelectric drive circuitry is disclosed. The piezoelectric drive circuitry may include a square wave generator that may generate a square wave signal at a first frequency. Further, the piezoelectric drive circuitry may include a pulse width modulator that
5 may generate a first PWM signal and a second PWM signal based on the square wave signal. In an embodiment, the first PWM signal and the second PWM signal may be complementary in phase to each other. Further, the piezoelectric drive circuitry may include two semiconductor switches to alternatively supply electrical power to a piezoelectric actuator, based on the first PWM signal and the second PWM signal. In an embodiment, the piezoelectric actuator may
10 vibrate at the first frequency upon application of the electric power.

[007] In another embodiment, a system for fluidic separation is disclosed. The system may include a piezoelectric drive circuitry and a fluid tube. In an embodiment, the piezoelectric drive circuitry may include a square wave generator to generate a square wave signal at a first frequency. Further, the piezoelectric drive circuitry may include a pulse width modulator that
15 may generate a first PWM signal and a second PWM signal based on the square wave signal. In an embodiment, the first PWM signal and the second PWM signal may be complementary in phase to each other. Further, a piezoelectric actuator may be configured to vibrate at the first frequency based on the first PWM signal and the second PWM signal. In an embodiment, the first PWM signal and the second PWM signal may be alternatively applied to the piezoelectric
20 actuator via two semiconductor switches. Further, the fluid tube may be placed above the piezoelectric actuator. In an embodiment, the fluid tube may include a channel that may receive a fluidic mixture from an inlet. In an embodiment, the fluidic mixture may include a first liquid having a first density. In an embodiment, the first liquid may separate from the fluidic mixture based on an application of vibrations along a length of the channel using the piezoelectric
25 actuator. In an embodiment, the first liquid may exit the channel from the at least one outlet of the channel.

[008] In another embodiment, a method for performing fluidic separation is disclosed. The method may include receiving a fluidic mixture from an inlet of a channel. In an embodiment, the fluidic mixture may include a first liquid having a first density. Further, the method may
30 include applying vibrations along a length of the channel using a piezoelectric actuator operating at a predefined frequency. Furthermore, the method may include receiving the first liquid from the at least one outlet. In an embodiment, the piezoelectric actuator may be

configured to vibrate at the predefined frequency by generating, by a square wave generator, a square wave signal at the predefined frequency. Further, the piezoelectric actuator may be configured to vibrate at the predefined frequency by generating, by a pulse width modulator, a first PWM signal and a second PWM signal based on the square wave signal. In an embodiment, the first PWM signal and the second PWM signal may be complementary in phase to each other. Further, the piezoelectric actuator may be configured to vibrate at the predefined frequency by alternatively switching, by two semiconductor switches, the first PWM signal and the second PWM signal to the piezoelectric actuator.

[009] Various objects, features, aspects, and advantages of the inventive subject matter will become more apparent from the following detailed description of preferred embodiments, along with the accompanying drawing figures in which like numerals represent like components.

BRIEF DESCRIPTION OF THE DRAWINGS

[010] The accompanying drawings, which are incorporated in, and constitute a part of this disclosure, illustrate exemplary embodiments, and together with the description, serve to explain the disclosed principles.

[011] **FIG. 1** illustrates a block diagram of a piezoelectric drive circuitry, in accordance with an embodiment of the present disclosure.

[012] **FIG. 2** illustrates a schematic circuit layout of a piezoelectric drive circuitry, in accordance with an embodiment of the present disclosure.

[013] **FIG. 3** illustrates a top view of a system for fluidic separation, in accordance with an embodiment of the present disclosure.

[014] **FIG. 4** illustrates a flowchart of a method for fluidic separation, in accordance with an embodiment of the present disclosure.

DETAILED DESCRIPTION OF THE DRAWINGS

[015] Exemplary embodiments are described with reference to the accompanying drawings. Wherever convenient, the same reference numbers are used throughout the drawings to refer to the same or like parts. While examples and features of disclosed principles are described

herein, modifications, adaptations, and other implementations are possible without departing from the scope of the disclosed embodiments. It is intended that the following detailed description be considered exemplary only, with the true scope being indicated by the following claims. Additional illustrative embodiments are listed.

5 [016] Further, the phrases “in some embodiments”, “in accordance with some embodiments”, “in the embodiments shown”, “in other embodiments”, and the like mean a particular feature, structure, or characteristic following the phrase is included in at least one embodiment of the present disclosure and may be included in more than one embodiment. In addition, such phrases do not necessarily refer to the same embodiments or different embodiments. It is intended that
10 the following detailed description be considered exemplary only, with the true scope being indicated by the following claims.

[017] The current disclosure helps in performing separation of a fluid from a fluidic mixture using a piezoelectric drive circuitry based on difference in densities of various fluids in the fluidic mixture. One such exemplary fluidic mixture may be blood. In various implementations,
15 there is a requirement of separating various components of blood. In an embodiment, plasma may be separated from blood using one or more separation processes. Conventionally, centrifugal force-based separation techniques were used for separation of plasma (liquid part of blood) from blood corpuscles (solid part of blood). Such techniques may require a centrifuge that may rotate the blood sample at a high speed which may lead to separation of plasma due
20 to its difference of mass density from that of the blood corpuscles. There are a few drawbacks governing the rotational speed of the centrifuge. There is a possibility of structural damage of the blood corpuscles in case of a high rotational speed of the centrifuge, and an insufficient separation of plasma in case of relatively lower rotation speed of the centrifuge. The current disclosure provides a piezoelectric driven system may be used for separation of fluidic mixtures
25 such as blood.

[018] References will now be made to exemplary embodiments of the disclosure, as illustrated in the accompanying drawings. Wherever possible, the same numerals have been used to refer to the same or like parts. The following paragraphs describe the present disclosure with reference to **FIGs. 1-4**.

30 [019] Referring now to **FIG. 1**, a block diagram of a piezoelectric drive circuitry 100 is illustrated, in accordance with some embodiments of the present disclosure. The piezoelectric

drive circuitry 100 may include a square wave generator 102 electronically and communicably coupled to a pulse width modulator (PWM) 104. Further, the piezoelectric drive circuitry 100 may include two semiconductor switches 106a, 106b and a piezoelectric actuator 108. In an embodiment, the square wave generator 102 and the pulse width modulator 104 may be implemented using one or more microcontroller(s). The square wave generator 102 may be any ASIC or any other device or circuit of an oscillator which may generate square wave of predefined frequency. The square wave generator 102 may be selected from Integrated Circuits (ICs) configured to generate the square wave signal of predefined frequency based on selection of resistance value of a variable resistor connected to the square wave generator 102. In an embodiment, examples of the oscillator ICs may include, but not limited to, LTC6907, MAX038, ICL8038, etc.

[020] In an embodiment, the predefined frequency may be adjustable in a range of about 40 kHz to about 4 MHz, based on selection of the resistance value of the variable resistor that may be in a range of about 50K Ohms to 5 Mega Ohms.

[021] In an embodiment, the square wave output by the square wave generator 102 may be fed as input to the pulse width modulator 104. The pulse width modulator may implement a Half bridge inverter configured to generate a first PWM signal and a second PWM signal based on the square wave signal. It is to be noted that the first PWM signal and the second PWM signal may be complementary in phase to each other. In an embodiment, half bridge ICs configured to generate the first PWM signal and the second PWM signal complementary in phase to each other may include, but not limited to, LMG1210, etc.

[022] In an embodiment, the first PWM signal and the second PWM signal complementary in phase to each other may be utilized to operate a pair of semiconductor switches 106a, 106b. Accordingly, the two semiconductor switches 106a, 106b may alternately supply electrical power to the piezoelectric actuator 108 that may vibrate at the predefined frequency based on the switching of the two semiconductor switches 106a, 106b. In an embodiment, each of the two semiconductor switches 106a, 106b may be, but not limited to, MOSFET, IGBT, or BJT.

[023] In an embodiment, as discussed in later embodiments, the vibrations of the piezoelectric actuator 108 may be transmitted to a fluid tube that may be placed in proximity to the piezoelectric actuator 108. The fluid tube may include a channel configured to transmit a fluidic mixture from an inlet to at least one outlet. The fluidic mixture may include at least first liquid

having a first density. The first liquid separates from the fluidic mixture based on an application of vibrations from the piezoelectric actuator 108. The vibrations are applied along a length of the channel while the fluidic mixture flows along the length of the channel. Due to difference in density the first liquid may be separated from the fluidic mixture due to the vibrations from the piezoelectric actuator 108. The first liquid may exit the channel from the at least one outlet of the fluid tube. In an embodiment, the fluidic mixture may include blood and the first liquid may be plasma which is separated from the blood due to vibrations from the piezoelectric actuator 108 at a frequency of about 2MHz.

[024] Referring now to **FIG. 2**, a schematic circuit layout of the piezoelectric drive circuitry, in accordance with some embodiment of the present disclosure. In an embodiment, the layout 200 depicts the circuit layout of the piezoelectric drive circuitry 100. The schematic circuit layout 200 includes the square wave generator 102, the pulse width modulator 104, two semiconductor switches 106a, 106b and the piezoelectric actuator 108. The square wave generator 102 may generate a square wave signal at a predefined frequency. The square wave generator 102 may be, selected as, but not limited to, IC LTC6907. The first frequency may be adjustable based on a selection of a resistance value of a variable resistor 202 of the square wave generator 102. In an embodiment, the variable resistor 202 may be calibrated to change/vary a frequency of the square wave signal of frequency in range of about 40 kHz up to about 4 MHz. As mentioned, the one or more variable resistor 202 may include a potentiometer, a rheostat, a thermistor, and/or a magneto resistor etc. having a resistance value in the range of about 50K Ohms to about 5 Meg Ohms.

[025] In an embodiment, the square wave generated at the predefined frequency by the square wave generator 102 may be inputted to the pulse width modulator 104. The pulse width modulator 104 may be configured as a half bridge circuitry. Further, on receiving the square wave signal, the pulse width modulator 104 may generate a first pulse width modulated (PWM) signal, and a second pulse width modulated (PWM) signal, based on the square wave signal. The first PWM signal and the second PWM signal may be complementary in phase with each other, and thus the first PWM signal, and the second PWM may be referred as complementary PWM abbreviated as CPWM. The pulse width modulator 104 may be, selected as, but not limited to, IC LMG1210.

[026] In an embodiment, the circuitry 200 may include two semiconductor switches 106a and 106b. Further, one of the first PWM signal and the second PWM signal is supplied to each of

the semiconductor switches 106a and 106b to alternately open and close the two semiconductor switches 106a and 106b. Accordingly, the two semiconductor switches 106a and 106b may alternately supply electrical power to the piezoelectric actuator 108. This alternate application of electric power (that may include electric potential/electric current) to the piezoelectric actuator 108 may lead to generation of vibrations in the piezoelectric actuator 108 at the predefined frequency. In an embodiment, the semiconductor switches 106a and 106b may be a MOSFET, an IGBT, or a BJT.

[027] Referring now to **FIG. 3** a top view of the system for fluidic separation is illustrated, in accordance with some embodiment of the present disclosure. The system 300 may include a fluid tube 302 may include a channel 304. The channel 304 may include an inlet 306 through which a fluidic mixture may enter the channel 304. The fluid tube 302 may be placed in proximity to the piezoelectric actuator 108. In an embodiment, the fluid tube 302 may be placed above the piezoelectric actuator 108. The piezoelectric actuator 108 may receive actuating electrical energy from the piezoelectric drive circuitry 100 (not shown in figure). The electrical energy may actuate the piezoelectric actuator 108 to vibrate at the predefined frequency as described above. In an embodiment, the fluid tube 302 may be placed/engrooved on a plate/wafer that may be fabricated using any combination of composite and/or metalloid including silicon. The fluid tube 302 may be operatively coupled with the piezoelectric actuator 108 such that vibration of the piezoelectric actuator 108 may be transferred to the fluid tube 302 with channel 304 transmitting the fluidic mixture. In an embodiment, width of the channel 304 may be in a range of 1 micrometer to 100 micrometer. Further, the channel 304 may be configured to receive a fluidic mixture from an inlet 306. The fluidic mixture may include a combination of liquids, semi-solids, and/or solids. In an embodiment, the fluidic mixture may include a first liquid having a first density different than any other liquids in the fluidic mixture. Due to application of vibrations from the piezoelectric actuator 108, at least a first liquid may get separated from the fluidic mixture and move towards the periphery 312 of the channel 304 due to difference in density. In an embodiment, the first liquid may exit the channel 304 from an outlet 310 and the residual fluidic mixture may remain in the center 314 of the channel 304 and may exit the channel 304 from another outlet 308.

[028] In an embodiment, the fluid mixture may include a blood sample, such that the fluid mixture may enter from the inlet 306, and further may pass through the channel 304. In an embodiment, blood includes plasma having different density than other components of the

blood such as blood corpuscles. As disclosed in the previous embodiments, the vibrations from the piezoelectric actuator 108, may be transmitted along a length of the channel 304. Due to difference in mass density of the plasma and other components of the blood, the vibrations along the length of the channel may lead to separation of the plasma from the blood sample.

5 Further, the plasma may collect along a periphery 312 of the channel 304 leaving the residual blood at the center 314 of the channel 304 as shown. To maintain a continuity of the flow, the fluid mixture may be collected at the outlet 308, wherein the separated plasma may be collected at the outlet 308. It is to be noted the system 300 may allow extraction of 90% pure plasma from blood.

10 **[029]** Referring now to **FIG. 4**, a flowchart of a method for performing fluidic separation, in accordance with some embodiments of the present disclosure. In an embodiment, method 400 may include a plurality of steps that may be performed to separate a first liquid from a fluidic mixture using the system 300.

15 **[030]** At step 402, the method may initiate by receiving a fluidic mixture from the inlet 306 of the channel 304. In an embodiment, the fluidic mixture may include a first liquid having a first density. As disclosed in the previous embodiments, the fluidic mixture may be blood that may include plasma as the first liquid as one of the components of the blood.

20 **[031]** Further at step 404, vibrations may be applied along a length of the channel 304 using a piezoelectric actuator 108 operating at a predefined frequency. In an embodiment, the vibrations may lead to separation of the first fluid from the fluidic mixture due to difference in density of the first liquid from other components of the fluidic mixture.

25 **[032]** As disclosed in the previous embodiments, the piezoelectric actuator 108 may generate vibrations at the predefined frequency based on generation of square wave signal at predefined frequency. Further, at step 406, the square wave signal at the first frequency may be generated by the square wave generator 102. The square wave generator 102 may include a variable resistor 202 based on which the predefined frequency may be selected in range of about 40 KHz to about 4 MHz based on selection of a resistance value of the variable resistor 202. In an embodiment, the resistance value of the variable resistor may be in a range of about 50K Ohms to 5 Meg Ohms. Further, at step 408, the pulse width modulator 104 may generate a first PWM
30 signal, and a second PWM signal based on the square wave signal generated at step 408. In an embodiment, the first PWM signal may be complementary in phase with the second PWM

signal. Further, at step 410, the first PWM signal and the second PWM signal may be alternately applied to the piezoelectric actuator 108 by the two semiconductor switches 106a and 106b. In an embodiment, the two semiconductor switches 106a and 106b may be switched alternately based on the first PWM signal and the second PWM signal. Accordingly, electrical energy may be alternately supplied to the piezoelectric actuator 108 in order for it to vibrate at the predefined frequency. The two semiconductor switches 106a and 106b may be a MOSFET, an IGBT, or a BJT.

[033] Further at step 412, the first fluid may be received from the at least one outlet 304 out of the one or more outlets of the channel 304.

[034] In the drawings and specification there has been set forth preferred embodiments of the invention, and although specific terms are employed, these are used in a generic and descriptive sense only and not for purposes of limitation. Changes in the form and the proportion of parts, as well as in the substitution of equivalents, are contemplated as circumstances may suggest or render expedient without departing from the spirit or scope of the invention.

[035] The illustrated steps are set out to explain the exemplary embodiments shown, and it should be anticipated that ongoing technological development will change the manner in which particular functions are performed. These examples are presented herein for purposes of illustration, and not limitation. Alternatives (including equivalents, extensions, variations, deviations, etc., of those described herein) will be apparent to persons skilled in the relevant art(s) based on the teachings contained herein. Such alternatives fall within the scope and spirit of the disclosed embodiments.

[036] It is intended that the disclosure and examples be considered as exemplary only, with a true scope and spirit of disclosed embodiments being indicated by the following claims.

WE CLAIM:

1. A piezoelectric drive circuitry (100), comprising:

a square wave generator (102) configured to generate a square wave signal at a predefined frequency;

a pulse width modulator (104) configured to generate a first PWM signal and a second PWM signal based on the square wave signal, wherein the first PWM signal and the second PWM signal are complementary in phase to each other; and

two semiconductor switches (106a, 106b) configured to alternatively supply electrical power to a piezoelectric actuator (108), based on the first PWM signal and the second PWM signal,

wherein the piezoelectric actuator (108) vibrates at the predefined frequency upon application of the electric power.

2. The piezoelectric drive circuitry (100) as claimed in claim 1, wherein the predefined frequency is adjustable based on a selection of a resistance value of a variable resistor (202) of the square wave generator (102).

3. The piezoelectric drive circuitry (100) as claimed in claim 2, wherein the predefined frequency is in a range of about 40 kHz to about 4 MHz, and wherein the resistance value of the variable resistor (202) is in a range of about 50K Ohms to 5 Meg Ohms.

4. The piezoelectric drive circuitry (100) as claimed in claim 1, wherein each of the two semiconductor switches (106a, 106b) is a MOSFET, an IGBT, or a BJT.

5. The piezoelectric drive circuitry (100) as claimed in claim 1, wherein the pulse width modulator (104) comprises a half bridge circuitry to generate the first PWM signal, and the second PWM signal.

6. A system (300) for fluidic separation, comprising:

a piezoelectric drive circuitry (100) comprising:

a square wave generator (102) configured to generate a square wave signal at a predefined frequency;

a pulse width modulator (104) configured to generate a first PWM signal and a second PWM signal based on the square wave signal,

wherein the first PWM signal and the second PWM signal are complementary in phase to each other; and

a piezoelectric actuator (108) configured to vibrate at the predefined frequency based on the first PWM signal and the second PWM signal,

wherein the first PWM signal and the second PWM signal are alternatively applied to the piezoelectric actuator (108) via two semiconductor switches (106a, 106b); and

a fluid tube (312) placed above the piezoelectric actuator (108), wherein the fluid tube (312) comprises:

a channel configured to receive a fluidic mixture from an inlet (306);

wherein the fluidic mixture comprises a first liquid having a first density, and

wherein the first liquid separates from the fluidic mixture based on an application of vibrations along a length of the channel using the piezoelectric actuator (108), and

wherein the first liquid exits the channel from at least one outlet (308, 310) of the channel.

7. The system (300) as claimed in claim 6, wherein the first frequency is adjustable based on a selection of a resistance value of a variable resistor (202) of the square wave generator (102) and the first frequency is in a range of about 40 kHz to about 4 MHz, and wherein the resistance value of the variable resistor (202) is in a range of about 50K Ohms to 5 Meg Ohms.

8. The system (300) as claimed in claim 6, wherein the fluidic mixture comprises blood, wherein the first liquid comprises plasma, and wherein the plasma separates from the blood based on the application of vibrations at about 2 MHz using the piezoelectric actuator (108).

9. A method for performing fluidic separation, comprising:

receiving a fluidic mixture from an inlet (306) of a channel, wherein the fluidic mixture comprises a first liquid having a first density;

applying vibrations along a length of the channel using a piezoelectric actuator (108) operating at a predefined frequency; and

receiving, from the at least one outlet (308, 310), the first liquid,
wherein the piezoelectric actuator (108) is configured to vibrate at the predefined frequency by:
generating, by a square wave generator (102), a square wave signal at the predefined frequency,
generating, by a pulse width modulator (104), a first PWM signal and a second PWM signal based on the square wave signal,
wherein the first PWM signal and the second PWM signal are complementary in phase to each other,
alternatively applying, by two semiconductor switches, the first PWM signal and the second PWM signal to the piezoelectric actuator.

10. The method as claimed in claim 9, wherein the fluidic mixture comprises blood, wherein the first liquid comprises plasma, and wherein the plasma separates from the blood based on the application of vibrations at the predefined frequency of about 2 MHz using the piezoelectric actuator (108).

11. The method as claimed in claim 9, wherein the square wave generator (102) comprises a variable resistor (202), and the predefined frequency is selected based on selection of a resistance value of the variable resistor (202).

12. The method as claimed in claim 11, wherein the predefined frequency is in a range of about 40 kHz to about 4 MHz, and wherein the resistance value of the variable resistor (202) is in a range of about 50K Ohms to 5 Meg Ohms.

Dated this 08th day of September 2023

-- Digitally Signed--

Bhanu Prasad
(INPA No: **3253**)
Head, IPR Dept.,
L&T Technology Services Limited,
DLF 3rd Block, 2nd Floor,
Manapakkam, Chennai - 600089.

ABSTRACT

PIEZOELECTRIC DRIVE CIRCUITRY AND SYSTEM AND METHOD THEREOF

A method and system of piezoelectric drive circuitry (100) is disclosed. The method includes receiving a fluidic mixture from an inlet of a channel. Vibration is applied along the length of the channel using a piezoelectric actuator (108) operating at a predefined frequency. The first liquid is received from at least one outlet (304, 308). The piezoelectric actuator (108) is configured to vibrate at a predefined frequency by a wave signal is generated at the predefined frequency, a first PWM signal and a second PWM signal is generated based on the square wave signal, the first PWM signal and the second PWM signal are alternatively applied to the piezoelectric actuator (108).

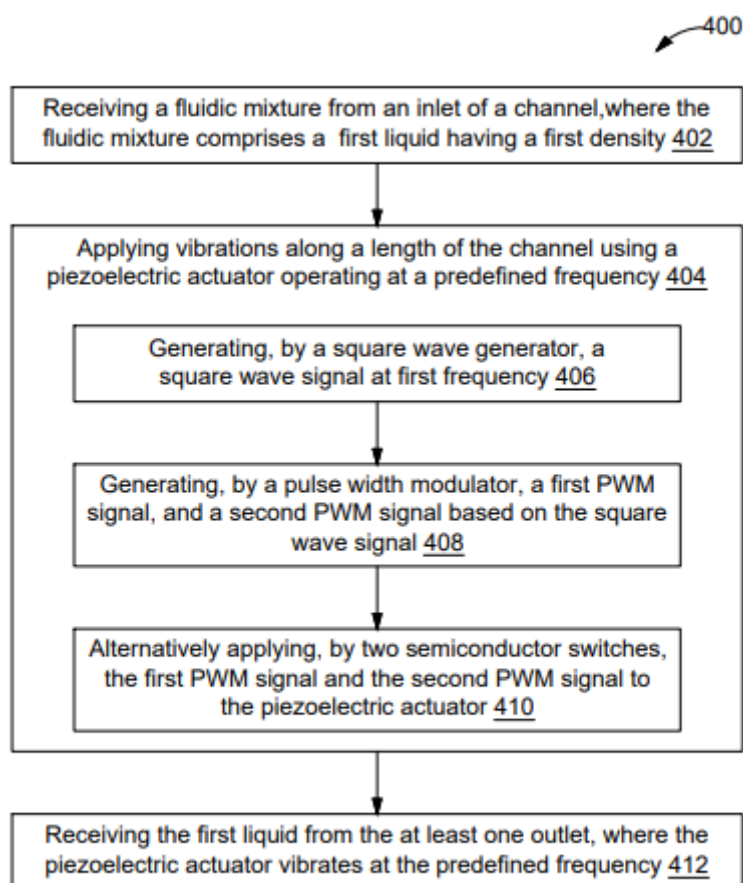

FIG. 4

1/4

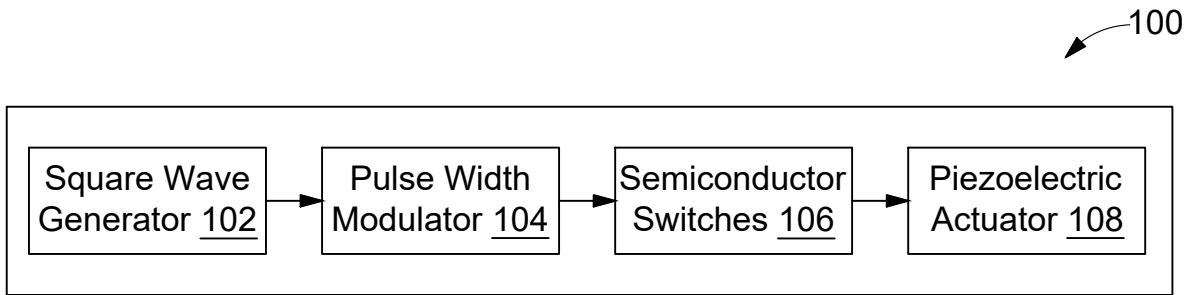

FIG. 1

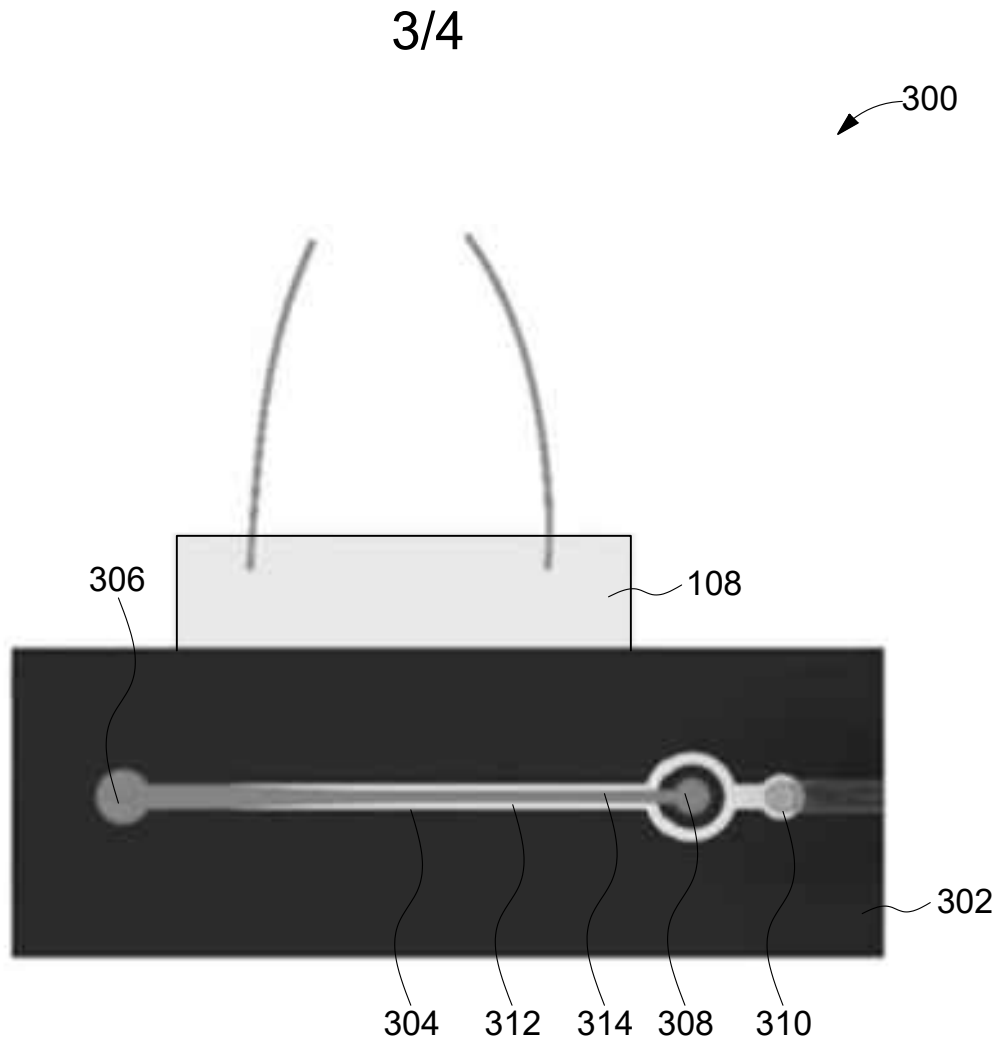

FIG. 3

4/4

400

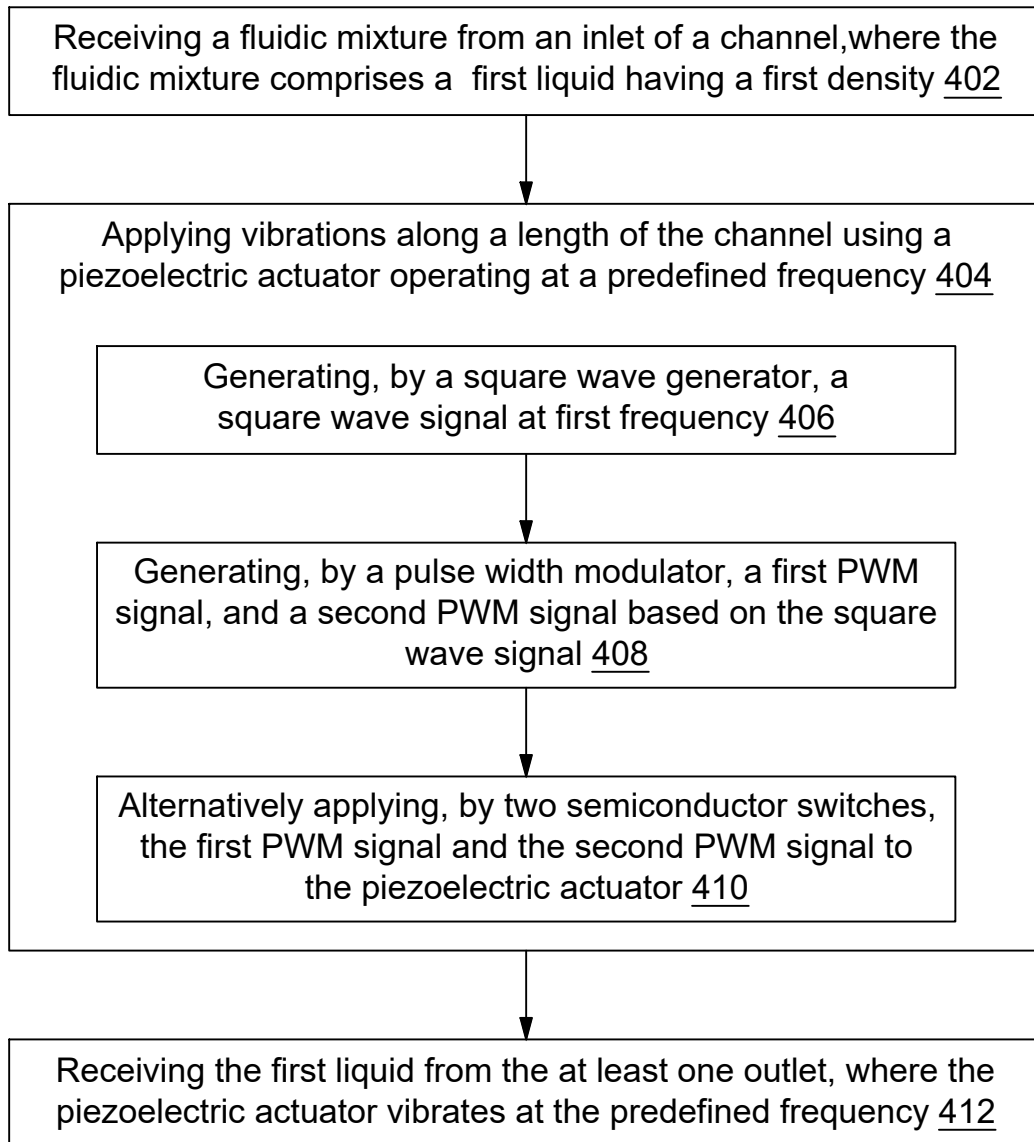

FIG. 4