

## (12) Indian Patent Application

---

(21) Application Number: 202341070401

(22) Filing Date: 16/10/2023      (43) Publication Date: 29/12/2023

(71) Applicant(s): L&T TECHNOLOGY SERVICES LIMITED

(72) Inventor(s): Surendran, Sooraj  
Tiwari, Biteshnath Raviprakash  
Raghavan, Rangachar Narasimha Moorthy Vijaya

(51) International Classifications: G06N 20/00      G05B 23/02      G06F 40/226      G06F 21/57      G06N 3/08

(54) Title: METHOD AND SYSTEM OF VALIDATING SCHEMATIC DESIGNS AND PROVIDING RECOMMENDATIONS

(57) Abstract: A method and system of validating a schematic design is disclosed. A processor determines a plurality of elements in the schematic design published in a schematic document. A plurality of parameters of each of the plurality of elements is determined. Each of the plurality elements is classified as a component type from a plurality of component types based on the plurality of parameters of each of the plurality elements and using the one or more machine learning models. The schematic design is validated by determining a similarity score corresponding to each of the plurality of parameters of each of the plurality of elements and/or at least one connection status of at least one of the plurality of elements in the schematic design based on the reference schematic data using the one or more machine learning models. A report is output comprising one or more recommendations based on the validation and a result of the validation.

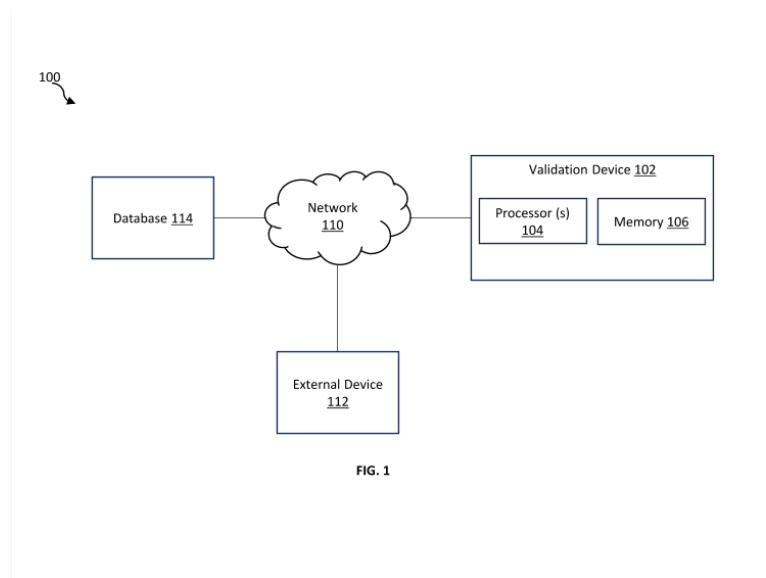

# **FORM 2**

THE PATENTS ACT 1970  
(39 OF 1970)

&

The Patent Rules, 2003

## **Complete Specification**

(See Section 10 and Rule 13)

### **1. TITLE OF THE INVENTION**

**METHOD AND SYSTEM OF VALIDATING SCHEMATIC DESIGNS AND PROVIDING RECOMMENDATIONS**

### **2. APPLICANT(S)**

(a) NAME : **L&T TECHNOLOGY SERVICES LIMITED**

(b) NATIONALITY : **INDIAN**

(c) ADDRESS : **DLF IT SEZ Park, 2nd Floor – Block 3**

**1/124, Mount Poonamallee Road,**

**Ramapuram, Chennai – 600 089,**

**INDIA.**

### **3. PREAMBLE TO THE DESCRIPTION**

#### **COMPLETE**

The following specification particularly describes the invention and the manner in which it is to be performed

## **DESCRIPTION**

### **Technical Field**

[001] This disclosure relates generally to machine learning based validation methodology, and more particularly to a machine learning based validation of IC schematic designs.

## **BACKGROUND**

[002] Verifying schematics with datasheets has become increasingly challenging as complex designs now often include multi-page schematics. The presence of multiple-page schematics significantly raises the likelihood of errors and overlooked pages, leading to incomplete and inaccurate verification. Most verification systems are compatible with a specific schematic format, limiting the versatility of the tool.

[003] Traditional IC design verification process includes manual verification executed by technicians who possess both experience and training in the relevant field. In due course, circuit simulation software emerged as a significant advancement over traditional methods, revolutionizing the process by making it significantly more convenient and efficient. However, such simulation software provides design level verification methodology and limited scope of rectification and verification during the PCB designing of the circuitry which may sometimes lead to failure of circuitry design.

[004] Therefore, there is a requirement for an efficient and effective methodology to validate schematic designs.

## **SUMMARY OF THE INVENTION**

[005] In an embodiment, a method of validating a schematic design is disclosed. The method may include, determining, by a processor, a plurality of elements in the schematic design published in a schematic document. In an embodiment, the determination of the plurality of elements may include determining at least one element feature by extracting text data in the schematic document based on a text extraction technique. Further, determination of the plurality of elements may include determining at least one element feature by determining one or more objects in the schematic document based on an object detection technique. The method may use one or more machine learning models for determining a plurality of parameters of each of the plurality of elements based on the text data and/or the one or more objects. The method may further use the one or more machine learning models for classifying each of the plurality elements as a component type from a plurality of component types based on the

plurality of parameters of each of the plurality elements and based on a predefined reference schematic data. The method may further use the one or more machine learning models for validating the schematic design by determining a similarity score corresponding to each of the plurality of parameters of each of the plurality of elements in the schematic design based on the predefined reference schematic data. In an embodiment, the one or more machine learning models may be trained to classify each of the plurality elements and validate the schematic design based on the predefined reference schematic data. In an embodiment, the predefined reference schematic data may include a list of plurality of element types and at least one predefined element feature corresponding to each of the plurality of elements types. The method may further include outputting a report that may include one or more recommendations based on the validation and a result of the validation.

**[006]** In another embodiment, a system of validating a schematic design is disclosed. The system may include a processor, a memory communicably coupled to the processor, wherein the memory may store processor-executable instructions, which when executed by the processor may cause the processor to determine a plurality of elements in the schematic design published in a schematic document. In an embodiment, the determination of the plurality of elements may include determining at least one element feature by extracting text data in the schematic document based on a text extraction technique. Further, the determination of the plurality of elements may include determining the at least one element feature by determining one or more objects in the schematic document based on an object detection technique. The processor may use one or more machine learning models to determine a plurality of parameters of each of the plurality of elements from the text data and/or the one or more objects. The processor may further use the one or more machine learning models to classify each of the plurality elements as a component type from a plurality of component types based on the plurality of parameters of each of the plurality elements and based on a predefined reference schematic data. The processor may further use the one or more machine learning models to validate the schematic design by determining a similarity score corresponding to each of the plurality of parameters of each of the plurality of elements in the schematic design based on the predefined reference schematic data. In an embodiment, the one or more machine learning models may be trained to classify each of the plurality elements and validate the schematic design based on the predefined reference schematic data. In an embodiment, the predefined reference schematic data may include a list of plurality of element types and at least one predefined element feature corresponding to each of the plurality of elements types. The

processor may further output a report that may include one or more recommendations based on the validation and a result of the validation.

[007] Various objects, features, aspects, and advantages of the inventive subject matter will become more apparent from the following detailed description of preferred embodiments, along with the accompanying drawing figures in which like numerals represent like components.

### **BRIEF DESCRIPTION OF THE DRAWINGS**

[008] The accompanying drawings, which are incorporated in and constitute a part of this disclosure, illustrate exemplary embodiments and, together with the description, serve to explain the disclosed principles.

[009] **FIG. 1** illustrates a block diagram of an exemplary validation system for validating a schematic design, in accordance with some embodiments of the present disclosure.

[010] **FIG. 2** is a functional block diagram of the validation device, in accordance with some embodiments of the present disclosure.

[011] **FIG. 3** illustrates an exemplary schematic design, in accordance with an embodiment of the present disclosure.

[012] **FIG. 4** depicts a table of an exemplary report, in accordance with some embodiment of the present disclosure.

[013] **FIG. 5** illustrates an exemplary digital graphical user interface (GUI) schematic design validation software, in accordance with an embodiment of the present disclosure.

[014] **FIG. 6** is a flowchart of a method for validating schematic designs, in accordance with some embodiments of the present disclosure.

### **DETAILED DESCRIPTION OF THE DRAWINGS**

[015] Exemplary embodiments are described with reference to the accompanying drawings. Wherever convenient, the same reference numbers are used throughout the drawings to refer to the same or like parts. While examples and features of disclosed principles are described herein, modifications, adaptations, and other implementations are possible without departing from the scope of the disclosed embodiments. It is intended that the following detailed

description be considered exemplary only, with the true scope being indicated by the following claims. Additional illustrative embodiments are listed.

**[016]** Further, the phrases “in some embodiments”, “in accordance with some embodiments”, “in the embodiments shown”, “in other embodiments”, and the like mean a particular feature, structure, or characteristic following the phrase is included in at least one embodiment of the present disclosure and may be included in more than one embodiment. In addition, such phrases do not necessarily refer to the same embodiments or different embodiments. It is intended that the following detailed description be considered exemplary only, with the true scope being indicated by the following claims.

**[017]** In the realm of electronic circuit design, the significance of meticulous component selection cannot be overstated. Opting for components that are not compatible, obsolete or designated as "last-time buy" can lead to a host of complications. Inefficiency in component selection can lead to disruptions in the supply chain, elevated production costs, and heightened vulnerability in inventory management.

**[018]** Further, adherence to standardized Printed Circuit Board (PCB) design guidelines is paramount to ensure the seamless integration, reliability, and performance of electronic products. Failing to follow these established guidelines can result in a myriad of challenges. These issues can culminate in costly redesigns, manufacturing delays, and ultimately, the production of electronic devices that are prone to malfunctions or failure. Therefore, recognizing the importance of diligently following PCB design recommendations becomes imperative in achieving efficient, cost-effective, and high-quality electronic circuitry. Accordingly, the present disclosure provides a method and a system for validating schematic designs and for providing recommendations with respect to the schematic designs.

**[019]** Referring now to **FIG. 1**, a block diagram of an exemplary validation system 100 for validating a schematic design, in accordance with some embodiments of the present disclosure is illustrated. The validation system 100 may include a validation device 102, an external device 112, and a database 114 communicably coupled to each other through a wired or a wireless communication network 110. The validation device 102 may include a processor 104 and a memory 106. In an embodiment, examples of processor(s) 104 may include, but are not limited to, an Intel® Itanium® or Itanium 2 processor(s), or AMD® Opteron® or Athlon MP® processor(s), Motorola® lines of processors, Nvidia®, FortiSOC™ system on a chip

processors or other future processors. In an embodiment, the memory 106 may store instructions that, when executed by the processor 104, and cause the processor 104 to validate schematic designs, as discussed in more detail below. In an embodiment, the memory 106 may be a non-volatile memory or a volatile memory. Examples of non-volatile memory may include but are not limited to, a flash memory, a Read Only Memory (ROM), a Programmable ROM (PROM), Erasable PROM (EPROM), and Electrically EPROM (EEPROM) memory. Further, examples of volatile memory may include but are not limited to, Dynamic Random Access Memory (DRAM), and Static Random-Access memory (SRAM).

**[020]** In an embodiment, the database 114 may be enabled in a cloud or a physical database and may store schematic documents and training data. In an embodiment, the training data may include predefined reference schematic data that may be provided by one or more vendors. In an embodiment, the database 114 may store data input by an external device 112 or output generated by the validation device 102. In an embodiment, the schematic document may include, but not limited to, images of schematic designs in one or more document formats. In an embodiment, the schematic document may be in any universal file formats such as, but not limited to, jpeg, png, Portable Document Format (PDF), etc.

**[021]** In an embodiment, the communication network 110 may be a wired or a wireless network or a combination thereof. The network 110 can be implemented as one of the different types of networks, such as but not limited to, ethernet IP network, intranet, local area network (LAN), wide area network (WAN), the internet, Wi-Fi, LTE network, CDMA network, 5G and the like. Further, network 110 can either be a dedicated network or a shared network. The shared network represents an association of the different types of networks that use a variety of protocols, for example, Hypertext Transfer Protocol (HTTP), Transmission Control Protocol/Internet Protocol (TCP/IP), Wireless Application Protocol (WAP), and the like, to communicate with one another. Further network 110 can include a variety of network devices, including routers, bridges, servers, computing devices, storage devices, and the like.

**[022]** In an embodiment, the validation device 102 may receive a request for validating schematic design published in a schematic document from the external device 112 through the network 110. In an embodiment, the validation device 102 and the external device 112 may be a computing system, including but not limited to, a smart phone, a laptop computer, a desktop computer, a notebook, a workstation, a portable computer, a personal digital assistant, a handheld, a scanner, or a mobile device. In an embodiment, the validation device 102 may be,

but not limited to, in-built into the external device 112 or may be a standalone computing device.

**[023]** In an embodiment, the processor 104 may perform various processing for validating schematic design. By way of an example, the processor 104 may determine a plurality of elements in the schematic design published in a schematic document. In an embodiment, the processor 104 may determine the plurality of elements by determining at least one element feature by extracting text data in the schematic document based on a text extraction technique. Further, the processor 104 may determine the plurality of elements by determining at least one element feature by determining one or more objects in the schematic document based on an object detection technique.

**[024]** Further, the processor 104 may use one or more machine learning models to determine a plurality of parameters of each of the plurality of elements from the text data and/or the one or more objects. In an embodiment, the plurality of parameters of each of the plurality of elements that may include a type information, an end of life information, a stock information, a capacity information, a make information, a connection information, etc.

**[025]** Further, the processor 104 may use the one or more machine learning models to classify each of the plurality elements as a component type from a plurality of component types based on the plurality of parameters of each of the plurality elements and based on a predefined reference schematic data.

**[026]** Further, the processor 104 may use the one or more machine learning models to validate the schematic design by determining a similarity score corresponding to each of the plurality of parameters of each of the plurality of elements and/or at least one connection status of at least one of the plurality of elements in the schematic design based on the predefined reference schematic data. In an embodiment, the one or more machine learning models may be trained to classify each of the plurality elements and validate the schematic design based on the predefined reference schematic data. In an embodiment, the predefined reference schematic data may include a list of plurality of element types and at least one element feature corresponding to each of the plurality of element types. Further, the processor 104 may output a report that may include one or more recommendations based on the validation and a result of the validation. In an embodiment, the report may include a list of plurality of elements and the corresponding plurality of parameters of each of the plurality of elements determined in the

schematic design. In an embodiment, the one or more recommendations may be determined based on the one or more machine learning models. In an embodiment, the one or more recommendations may be used to optimize the schematic designs by implementing the one or more recommendations. In an embodiment, the one or more machine learning models may be trained based on historical reports corresponding to the predefined reference schematic data. In an embodiment, the result of the validation may be determined as erroneous in case the similarity score corresponding to at least one of the plurality of parameters of at least one of the plurality of elements may be determined less than a predefined threshold. Further, the result of the validation may be determined as erroneous in case the similarity score corresponding to at least one connection status of at least one of the plurality of elements may be determined less than the predefined threshold.

**[027]** In an embodiment, the report may include the result of the validation and the similarity score corresponding to the at least one of the plurality of parameters of each of the plurality of elements and the at least one connection status of each of the plurality of elements. In an embodiment, the one or more recommendations in the report may include at least one substitute element corresponding to the at least one of the plurality of elements for which an error has been detected based on determination of the similarity score less than the predefined threshold. In an embodiment, the similarity score may be determined based on a comparison of at least one of the plurality of elements based on the at least one of the plurality of parameters and the predefined reference schematic data. In an embodiment, the similarity score may be less than the predefined threshold for elements that may be present in the schematic design and are not present in the reference schematic design data. In an embodiment, the one or more recommendations may further include at least one connection recommendation corresponding to the at least one of the plurality of elements having the similarity score less than the predefined threshold based on at least one connection status. For example, elements that may be determined as disconnected in the schematic design as compared to the reference schematic design data may have the similarity score less than the predefined threshold. In an embodiment, the one or more recommendations in the report may include displaying at least one printed circuit board design schematic corresponding to the schematic design based on one or more design recommendations, one or more connection recommendations and one or more location recommendations corresponding to each of the plurality of elements and corresponding to each of the plurality of parameters of each of the plurality of elements.

[028] Referring now to **FIG. 2**, a functional block diagram of the validation device 102, in accordance with some embodiments of the present disclosure. In an embodiment the validation device 102 may receive schematic design published in a schematic documents. The validation device 102 may include an element determination module 202, a text extraction module 204, an object determination module 206, a parameter determination module 208, a classification module 210, a validation module 212 and a report generation module 214.

[029] The element determination module 202 may determine a plurality of elements in the schematic design published in a schematic document to be validated by the validation device 102. The element determination module 202 may include the text extraction module 204 and the object determination module 206. The text extraction module 204 may determine at least one element feature by extracting text data from the schematic document using a text extraction technique. Further, the object determination module 206 may determine at least one element feature by determining one or more objects in the schematic design using an object detection technique.

[030] Referring now to **FIG. 3**, an exemplary schematic design 300 is illustrated, in accordance with an embodiment of the present disclosure. The schematic design 300 depicts an IC 302 that may be, but not limited to, a BME280 or BMP280. In an embodiment, the IC 302 may be any IC without limitation. The IC 302 includes pins 1-8 that may be accordingly connected in order to operationally configure the IC 302. In an embodiment, the schematic design 300 further provides various electrical elements as components that may be used to operationally configure the IC 302. As shown, the elements shown in the schematic 300 includes capacitors C1, C2, and resistors R1, R4. Further, the IC 302 may be connected to a 6 pin connector 304. In an embodiment, the elements may be determined based on determination of at least one element feature. In an embodiment, the element features may be determined by extracting text data in the schematic document by the text extraction module 204 using a text extraction technique. In an embodiment, text extraction technique may include, but not limited to, optical character recognition techniques. Further, Natural Language Processing (NLP) based models may be used to determine one or more element feature in the text data based on which elements may be determined. Further, the element features may be determined by determining one or more objects by the object determination module 206 in the schematic design using an object detection technique. For example, the element determination module 202 may determine resistors R1, R4 and capacitors C1, C2 based on the extraction of text data “R1 10K”, “R4

10K”, “0.1 $\mu$ F” and “1 $\mu$ F” respectively. Further, the element determination module 202 may determine the resistors R1, R4, the capacitors C1, C2 6 and pin connector 304 based on detection of corresponding objects depicting the resistors R1, R4, the capacitors C1, C2 6 and pin connector 304.

[031] Referring back to **FIG. 2**, the parameter determination module 208 may determine a plurality of parameters of each of the plurality of elements based on the text data and/or the one or more objects. The parameter determination module 208 may use one or more machine learning models to determine a plurality of parameters of each of the plurality of elements based on the text data and/or the one or more objects. The one or more machine learning models may be NLP based models that may be trained based on domain based data to determine one or more parameters corresponding to each of the elements from the text data in the schematic document. The plurality of parameters of each of the plurality of elements that may be determined may include a type information, an end of life information, a stock information, a capacity information, a make information, a connection information, a count/quantity information, etc.

[032] Referring back to **FIG. 3**, for the schematic 300, the parameter determination module 208 may determine the type of information of the plurality of elements as capacitors for C1, C2, resistors R1, R4, connectors 304, etc. Further, the parameter determination module 208 may capacity information for each of the plurality of elements such as capacitance values of C1, C2, resistance values of R1, R4. Further, the parameter determination module 208 may determine count information of each of the plurality of elements such as a number of capacitors and a number of resistors, etc.

[033] In an embodiment, the make information may be determined based on determination of any trademark text information provided in the schematic document corresponding to an element. Further, the end of life information and the stock information and a connection information may be determined based on a predefined reference schematic data. The predefined reference schematic data may be used as training data for training the one or more machine learning modules. In an embodiment, the predefined reference schematic data may include the end of life information of a plurality of predefined elements and their corresponding end of life information as provided by one or more vendors. In an embodiment, the predefined reference schematic data may include stock information of a plurality of predefined elements and their corresponding end of life information as provided by the one or more vendors.

[034] Further, the parameter determination module 208 may determine connection information of the schematic design 300 based on determination of connection lines based on a comparison with the reference schematic designs included in the predefined reference schematic data.

[035] Referring back to **FIG. 2**, the classification module 210 may classify each of the plurality elements as a component type from a plurality of component types based on the plurality of parameters of each of the plurality elements and using the one or more machine learning models. In an embodiment, the plurality elements may be classified as one of the component types such as, resistors, capacitors, power supply, inductors, etc. In an embodiment, the one or more machine learning models may be trained to classify each of the plurality elements based on the plurality of parameters of each of the plurality elements and the predefined reference schematic data. In an embodiment the one or more machine learning models may include object detection models that may include, but not limited to, R-CNN, Region-Based Convolutional Neural Networks), Fast R-CNN, YOLO (You Only Look Once), etc. In an exemplary embodiment, as shown in **FIG. 3**, the classification module 210 may classify R1, R4 as resistor component type and based on the type information and their corresponding capacity information.

[036] The validation module 212 may validate the schematic design by determining a similarity score corresponding to each of the plurality of parameters of each of the plurality of elements and/or at least one connection status of at least one of the plurality of elements in the schematic design based on the predefined reference schematic data using the one or more machine learning models. The one or more machine learning models may be trained based on the predefined reference schematic data. In an embodiment the one or more machine learning models may include recommendation models that may include, but not limited to, Recurrent Neural Networks (RNNs), etc. In an embodiment, a result of the validation may be determined as erroneous in case the similarity score corresponding to at least one of the plurality of parameters of at least one of the plurality of elements may be less than a predefined threshold. In an embodiment, the result of the validation may be determined as erroneous in case the similarity score corresponding to at least one connection status of at least one of the plurality of elements may be less than the predefined threshold. In an embodiment, the similarity score may be determined based on a comparison of the plurality of elements and their corresponding plurality of parameters determined for the schematic design and the predefined reference schematic data. In an embodiment, the one or more machine learning models may determine a

probability of match as a similarity score based on a comparison of the schematic design with the predefined reference schematic data. An error in validation may be determined in case of a mismatch determined for at least one element or a connection of at least one element in the schematic based on the comparison of the schematic design with the predefined reference schematic data.

[037] As shown in **FIG. 3**, a connection status of the pins 3 and 4 of IC 302 may be determined as not connected. The validation module 212 may determine a result of the validation of the schematic design 300 as erroneous based on the connection status of the pins 3 and 4 being determined as not connected. Further, the validation module 212 may determine may also determine a similarity score corresponding to each of the plurality of parameters of each of the plurality of elements such as R1, R4, C1 and C2 based on the predefined reference schematic data.

[038] Accordingly, the report generation module 214 of **FIG. 2**, may output a report that may include one or more recommendations based on the validation and a result of the validation. Referring now to **FIG. 4**, a table 400 of an exemplary report, in accordance with some embodiment of the present disclosure. The table 400 may include a list elements 402 determined in the schematic design, and the corresponding plurality of parameters of each of the plurality of elements 402 such as element type 403, capacity 404, description 406, a quantity 408, MPN 410, vendor 412 and footprint 414.

[039] Accordingly, the element type 403 may provide the type information of each of the plurality of elements 402. The capacity 404 may provide the capacity information of each of the plurality of elements 402 such as capacitance value of the plurality of capacitors C1, C2. Further, the description column 406 may provide the make information of the plurality of elements 402. Further, the quantity column 408 may provide the quantity/count information of the plurality of elements 402. Further, the MPN column 410 and vendor 412 may provide the make information such as part number and vendor manufacturing each of the plurality of elements 402. Further the footprint 414 may provide PCB design information of physical representations of the plurality of elements.

[040] In an embodiment, the report may further include the result of the validation based on the similarity score corresponding to the at least one of the plurality of parameters of each of the plurality of elements and the at least one connection status of each of the plurality of

elements 402. Further, the report generation module 214 may include in the report one or more recommendations that may be determined based on the one or more machine learning model. The one or more machine learning models may be trained based on historical reports corresponding to the predefined reference schematic data. In an embodiment, the one or more recommendations may be used to optimize the schematic designs by implementing the one or more recommendations.

**[041]** The one or more recommendations in the report may include at least one substitute element corresponding to the at least one of the plurality of elements having the similarity score less than the predefined threshold based on the at least one of the plurality of parameters. In another embodiment, the report may provide one or more recommendations suggesting at least one substitute element corresponding to the at least one of the plurality of elements having the similarity score greater than the predefined threshold based on the at least one of the plurality of parameters. Further, the report may include at least one connection recommendation corresponding to the at least one of the plurality of elements having the similarity score less than the predefined threshold based on at least one connection status. Accordingly, with respect to **FIG. 3**, the report generation module 214 may provide connection recommendations for the pins 3 and 4 of IC 302 for which the connection status has been determined as not connected. The report generation module 214 may further provide one or more recommendations including a substitute element corresponding to at least one of the elements C1, C2, R1, R4 in the schematic 300.

**[042]** In an embodiment, the report generation module 214 may determine based on the predefined reference schematic data that one of the elements may not be available in the required quantity with a particular vendor. Accordingly, the report generation module 214 may recommend a substitute from another vendor that may have the required quantity of the element. In another element, the report generation module 214 may recommend a substitute element for a particular element in the schematic 300, for which end of life may be approaching in near future. Accordingly, the schematic 300 may be designed based on substitute element in order to avoid any delay in manufacturing due to stock unavailability. Further, the schematic 300 may be designed based on substitute element in order to streamline an inventory of components by ordering components with same specifications to avoid redundancy and to keep uniformity in design. In an embodiment, the predefined reference schematic data may include stock information corresponding to a plurality of elements provided by a plurality of vendors.

Based on the stock information, the report generation module 214 may recommend sourcing one or more elements from a vendor that may have the required stock of the elements as per the schematic design.

[043] Further, the report generation module 214 may sub-include a PCB schematic recommendation module 216. The PCB schematic recommendation module 216 may determine at least one printed circuit board design schematic corresponding to the schematic design. In an embodiment, the report may include the at least one printed circuit board design schematic corresponding to the schematic design 300. Further, the PCB schematic recommendation module 216 may provide one or more design recommendations, one or more connection recommendations and one or more location recommendations corresponding to each of the plurality of elements and corresponding to each of the plurality of parameters of each of the plurality of elements in the schematic design. In an embodiment, the one or more recommendations from the PCB schematic recommendation module 216 may be based on component placement guidelines, trace width determination, differential signal routing, signal integrity considerations, Electromagnetic Compatibility (EMC) guidelines, layer stack up recommendations, component footprint selection, etc. In an embodiment, the component placement guidelines may include spatial relationships between elements, their thermal profiles, and signal flow requirements. It then recommends optimal placement of each element on the PCB to minimize interference, improve heat dissipation, and reduce signal propagation delays. In an embodiment, the recommendations related to trace width determination may include appropriate trace widths for power lines, ensuring safe and efficient power distribution based historical data on power requirements, voltage levels, and acceptable current densities of elements. In an embodiment, recommendations based on the differential signal routing may be based on determination of differential signal pairs in the schematic. Based on the differential signal routing, the PCB schematic recommendation module 216 may recommend specialized routing recommendations, such as maintaining consistent trace lengths and ensuring controlled impedance to minimize signal skew and interference.

[044] In an embodiment, recommendations based on signal integrity considerations may include recommendations to minimize signal reflections, impedance matching, and avoid crosstalk based on determination of high-frequency signals, signal integrity challenges, etc. In an embodiment, recommendations based on EMC guidelines may be to ensure that the PCB schematic design complies with electromagnetic compatibility requirements to reduce

interference and emissions. In an embodiment, layer stack up recommendations may include a number of PCB layers and their arrangement to optimize performance based on the complexity of the schematic design and ensuring signal isolation or power distribution. In an embodiment, recommendations based on component footprint selection may include generating cross-references component specifications with PCB footprint libraries and recommends the most suitable component footprints, reducing errors in component placement.

[045] In an exemplary embodiment, the one or more connection recommendations may include wire thickness of various connections being made between various elements in the PCB schematic design. In an embodiment, the wire thickness of various connections between various elements may depend on the capacity of the elements and the electrical energy passing through the connections, etc.

[046] Referring now to **FIG 5**, an exemplary digital graphical user interface (GUI) 500 of a schematic design validation software, in accordance with an embodiment of the present disclosure. The GUI 500 of the schematic design validation software may be displayed on an output display of the validation device 102. The GUI 500 may include a first display area 502 that may depict name and location of a selected schematic document. The first display area 502 may include a button interface to select a memory location in order to select and upload a schematic document. Further, the GUI 500 may include a second display area 504 that may include a selectable interface to select an automatic validation of the selected schematic document. Further, the GUI 500 may include a third display area 506. The third display area 506 may include an interface to select a manual validation of the uploaded schematic document. Further, the GUI 500 may include a fourth display area 508. The fourth display area 508 may depict an end of life (EOL) window. The EOL window may depict critical end of life information of the plurality of the elements. In an embodiment, the critical end of life information may correspond to list of elements in the schematic for which the end of life may be occurring within a predefined period, for example, in one week, one month, etc. Further, the GUI 500 may include a fifth display area 510. that may include a selectable interface to download PCB footprints of the plurality of elements in the schematic design. Further, the GUI 500 may include a sixth display area 512 that may include a selectable interface to display stock of the plurality of the element in the display area 514. Further, the GUI 500 may include a seventh display area 516 that may include a selectable interface to download a validation report of the schematic. Further, the GUI 500 may depict an eighth display area 518 that may include

a selectable interface to display and/or download a bill of material (BOM) list. In an embodiment, selection of the interface of the eighth display area 518 may allow an email to be sent to predefined email list containing the BOM list as attachment. In an embodiment, the BOM list may include a list of plurality of elements and their corresponding parameters such as capacity information, quantity information, make information, etc. Further, the GUI 500 may include a ninth display area 520 that may include a selectable interface to display an end of life (EOL) list in the EOL window 508. Further, the GUI 500 may include a tenth display area 522 that may display error information based on the validation of the uploaded schematic document.

[047] Referring now to **FIG. 6**, a flowchart of a method 600 for validating schematic designs, in accordance with some embodiments of the present disclosure. In an embodiment, method 600 may include a plurality of steps that may be performed by the processor 104 to validate schematic designs.

[048] At step 602, a plurality of elements may be determined in the schematic design published in a schematic document. The determination of the plurality of elements may include determining at least one element feature at step 604 by extracting text data in the schematic document based on a text extraction technique. Further, the determination of the plurality of elements may include determining at least one element feature at step 606, by determining one or more objects in the schematic document based on an object detection technique.

[049] Further, at step 608, a plurality of parameters of each of the plurality of elements may be determined based on the text data and/or the one or more objects using one or more machine learning models.

[050] Further, at step 610, each of the plurality elements may be classified as a component type from a plurality of component types based on the plurality of parameters of each of the plurality elements and based on a predefined reference schematic data using the one or more machine learning models.

[051] Further, at step 612, the schematic design may be validated by determining a similarity score corresponding to each of the plurality of parameters of each of the plurality of elements and/or a least one connection status of at least one of the plurality of elements in the schematic design based on the predefined reference schematic data using the one or more machine learning models. In an embodiment, the one or more machine learning models may be trained

to classify each of the plurality elements and validate the schematic design based on a predefined reference schematic data. The predefined reference schematic data may include a list of plurality of element types and at least one predefined element feature corresponding to each of the plurality of element types.

**[052]** Further at step 614, a report may be outputted by the processor 104 that may include one or more recommendations based on the validations based on the validation and a result of the validation.

**[053]** It is intended that the disclosure and examples be considered as exemplary only, with a true scope of disclosed embodiments being indicated by the following claims.

**WE CLAIM:**

1. A system (100) of validating a schematic design, comprising:

a processor (104); and

a memory (106) communicably coupled to the processor (104), wherein the memory (106) stores processor-executable instructions, which, on executing by the processor (104), cause the processor (104) to:

determine a plurality of elements in the schematic design published in a schematic document,

wherein the determination of the plurality of elements comprises determination of at least one element feature based on:

extraction of text data in the schematic document based on a text extraction technique; and/or

determination of one or more objects in the schematic design based on an object detection technique;

using one or more machine learning models:

determine a plurality of parameters of each of the plurality of elements based on the text data and/or the one or more objects;

classify each of the plurality elements as a component type from a plurality of component types based on the plurality of parameters of each of the plurality elements and based on a predefined reference schematic data;

validate the schematic design by determining a similarity score corresponding to each of the plurality of parameters of each of the plurality of elements and/or at least one connection status of at least one of the plurality of elements in the schematic design based on the predefined reference schematic data,

wherein the one or more machine learning models are trained to classify each of the plurality elements and validate the schematic design based on the predefined reference schematic data, and

wherein the predefined reference schematic data comprises a list of plurality of element types and at least one predefined element feature corresponding to each of the plurality of element types; and

output a report (400) comprising one or more recommendations based on the validation and a result of the validation.

2. The system (100) as claimed in claim 1, wherein the plurality of parameters of each of the plurality of elements (402) comprises a type information (403), an end of life information, a stock information, a capacity information (404), a make information (410) and a connection information.
3. The system (100) as claimed in claim 1, wherein the report (400) comprises a list of the plurality of elements and the corresponding plurality of parameters of each of the plurality of elements determined in the schematic design.
4. The system (100) as claimed in claim 1, wherein the result of the validation is determined as erroneous in case:
  - the similarity score corresponding to at least one of the plurality of parameters of at least one of the plurality of elements is less than a predefined threshold, and/or
  - the similarity score corresponding to at least one connection status of at least one of the plurality of elements is less than the predefined threshold.
5. The system (100) as claimed in claim 4, wherein the report (400) comprises the result of the validation and the similarity score corresponding to the at least one of the plurality of parameters of each of the plurality of elements and the at least one connection status of each of the plurality of elements.
6. The system (100) as claimed in claim 1, wherein the one or more recommendations in the report (400) comprises:
  - at least one substitute element corresponding to the at least one of the plurality of elements having the similarity score less than the predefined threshold based on the at least one of the plurality of parameters, and/or
  - at least one connection recommendation corresponding to the at least one of the plurality of elements having the similarity score less than the predefined threshold based on the at least one connection status.
7. The system (100) as claimed in claim 1, wherein the one or more recommendations in the report (400) comprises displaying at least one printed circuit board design schematic corresponding to the schematic design based on one or more design recommendations, one or more connection recommendations and one or more location recommendations

corresponding to each of the plurality of elements and corresponding to each of the plurality of parameters of each of the plurality of elements.

8. The system (100) as claimed in claim 1, wherein the schematic document is in a Portable Document Format.

9. A method (600) of validating a schematic design, the method comprising:

determining (602), by a processor (104), a plurality of elements in the schematic design published in a schematic document,

wherein the determination of the plurality of elements comprises determining at least one element feature by:

extracting (604), by the processor (104), text data in the schematic document based on a text extraction technique; and/or

determining (606), by the processor (104), one or more objects in the schematic design based on an object detection technique;

using one or more machine learning models:

determining (608), by the processor (104), a plurality of parameters of each of the plurality of elements from the text data and/or the one or more objects;

classifying (610), by the processor (104), each of the plurality elements as a component type from a plurality of component types based on the plurality of parameters of each of the plurality elements and based on a predefined reference schematic data;

validating (612), by the processor (104), the schematic design by determining a similarity score corresponding to each of the plurality of parameters of each of the plurality of elements and/or at least one connection status of at least one of the plurality of elements in the schematic design based on the predefined reference schematic data,

wherein the one or more machine learning models are trained to classify each of the plurality elements and validate the schematic design based on the predefined reference schematic data, wherein the predefined reference schematic data comprises a list of plurality of element types and at least one predefined element feature corresponding to each of the plurality of element types; and

outputting (614), by the processor (104), a report (400) comprising one or more recommendations based on the validation and a result of the validation.

10. The method (600) as claimed in claim 9, wherein the result of the validation is determined as erroneous in case:

the similarity score corresponding to at least one of the plurality of parameters of at least one of the plurality of elements is less than a predefined threshold, and/or

the similarity score corresponding to at least one connection status of at least one of the plurality of elements is less than the predefined threshold.

Dated this 16<sup>th</sup> day of October 2023

***--Digitally Signed--***

Bhanu Prasad (INPA No: 3253)  
Head, IPR Dept.,  
L&T Technology Services Limited,  
DLF 3rd Block, 2nd Floor,  
Manapakkam, Chennai - 600089.

**ABSTRACT**

**METHOD AND SYSTEM OF VALIDATING SCHEMATIC DESIGNS AND PROVIDING RECOMMENDATIONS**

A method and system of validating a schematic design is disclosed. A processor determines a plurality of elements in the schematic design published in a schematic document. A plurality of parameters of each of the plurality of elements is determined. Each of the plurality elements is classified as a component type from a plurality of component types based on the plurality of parameters of each of the plurality elements and using the one or more machine learning models. The schematic design is validated by determining a similarity score corresponding to each of the plurality of parameters of each of the plurality of elements and/or at least one connection status of at least one of the plurality of elements in the schematic design based on the reference schematic data using the one or more machine learning models. A report is output comprising one or more recommendations based on the validation and a result of the validation.

100  
↘

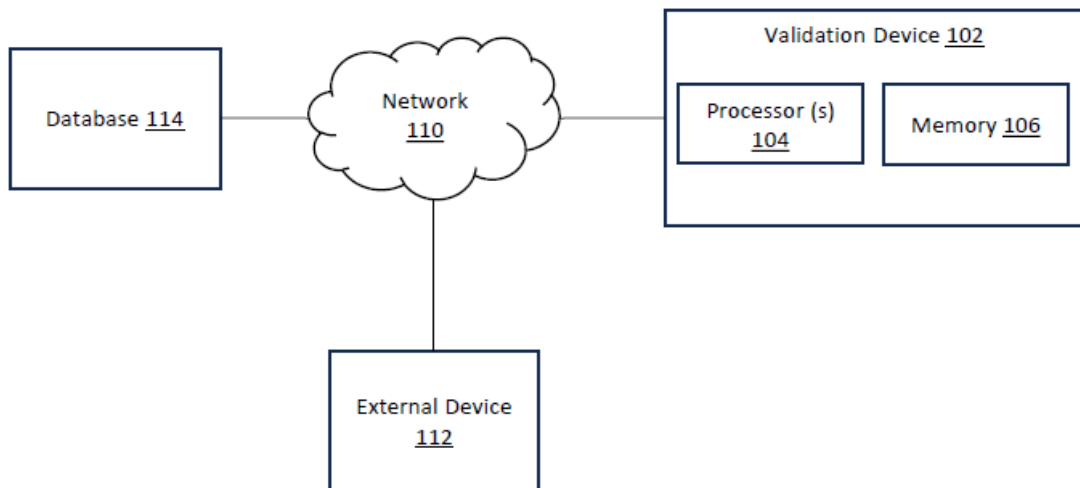

**FIG. 1**

100

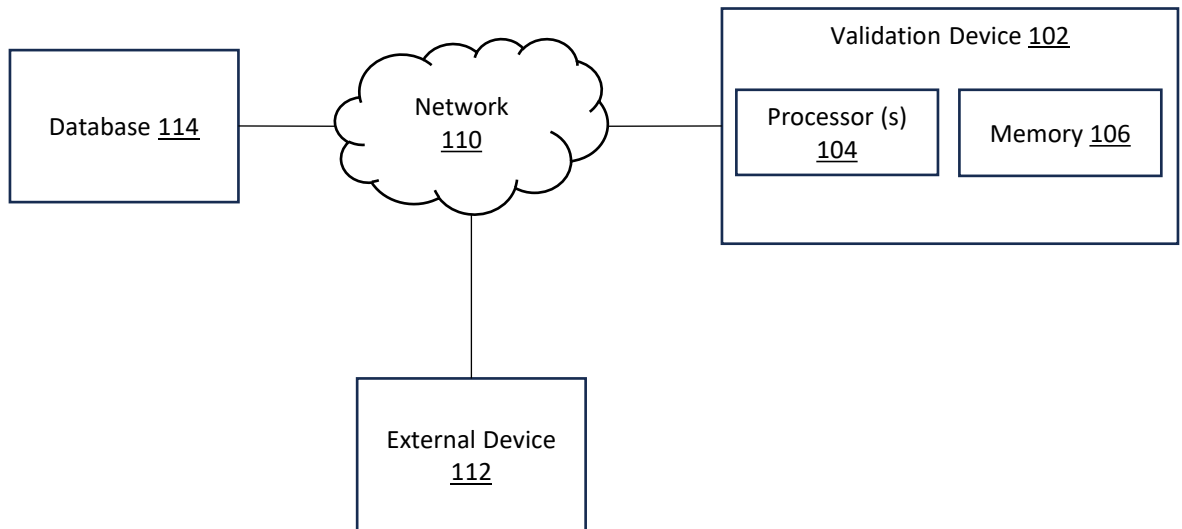

FIG. 1

--Digitally Signed--  
Bhanu Prasad  
(INPA No: 3253)  
Head, IPR Dept.,  
L&T Technology Services Limited,  
DLF 3rd Block, 2nd Floor,  
Manapakkam, Chennai - 600089.

200 →

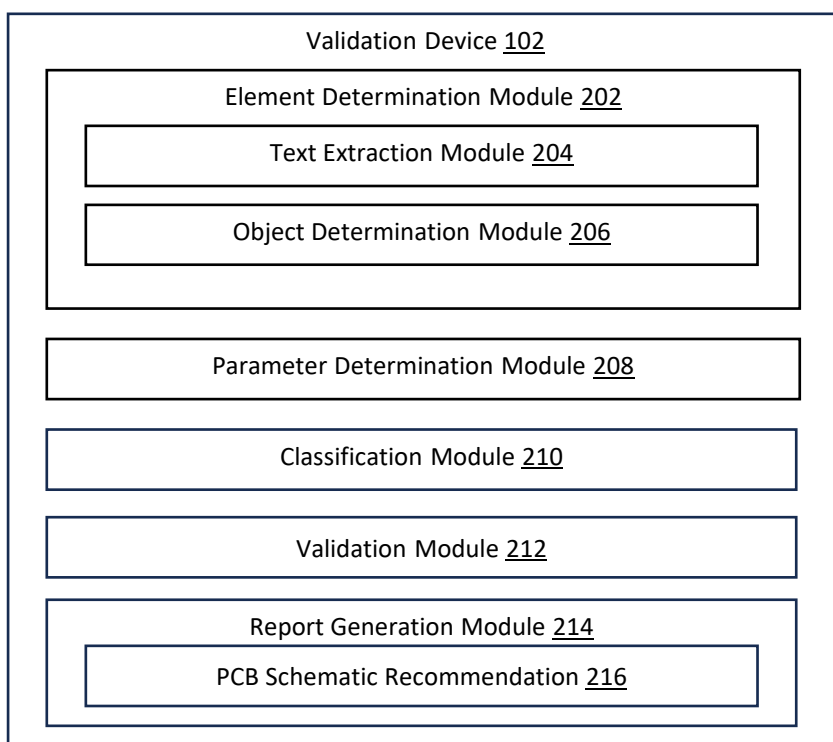

FIG. 2

--Digitally Signed--  
Bhanu Prasad  
(INPA No: 3253)  
Head, IPR Dept.,  
L&T Technology Services Limited,  
DLF 3rd Block, 2nd Floor,  
Manapakkam, Chennai - 600089.

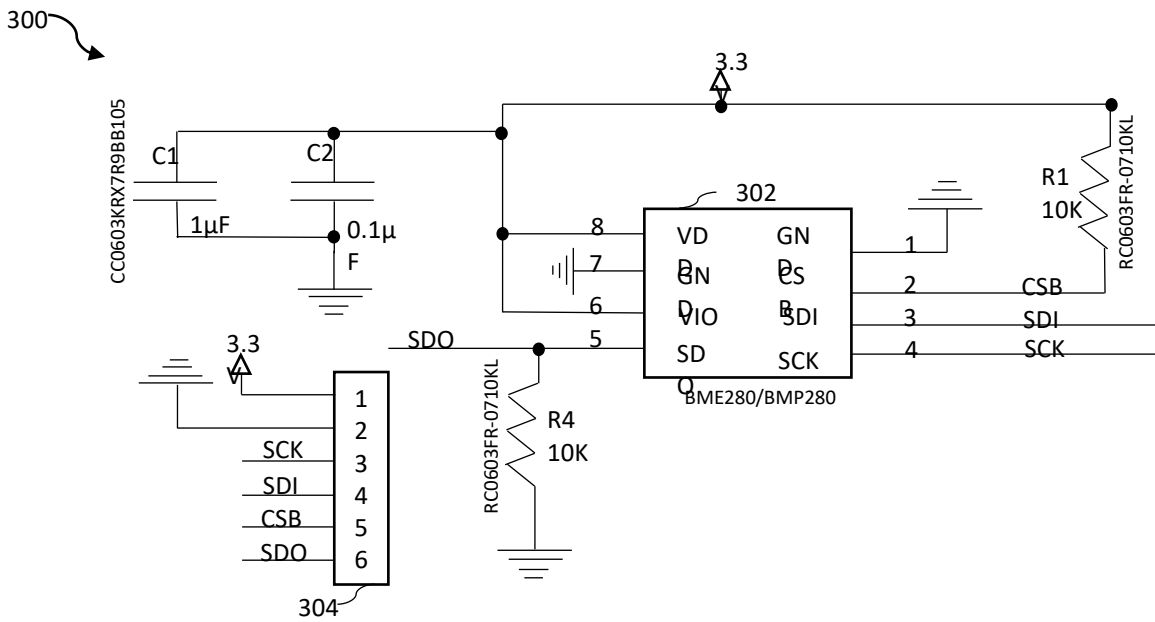

FIG. 3

--Digitally Signed--  
Bhanu Prasad  
(INPA No: 3253)  
Head, IPR Dept.,  
L&T Technology Services Limited,  
DLF 3rd Block, 2nd Floor,  
Manapakkam, Chennai - 600089.

400  

Element <u>402</u>	Element Type <u>403</u>	Capacity <u>404</u>	Description <u>406</u>	Quantity <u>408</u>	MPN <u>410</u>	Vendor <u>412</u>	Footprin t <u>414</u>
C1	Capacitor	0.1 $\mu$ F	0.1 $\mu$ F $\pm$ 10% 50V Ceramic	77	GCM155R71H104 KE02D	XYZ Co. Ltd.	C0402
C2	Capacitor	1 $\mu$ F	Multilayer Ceramic Capacitors	9	CC0603KRX7R9BB 105	XYZ Co. Ltd.	C0603
.	.	.	.	.	.	.	.
.	.	.	.	.	.	.	.
.	.	.	.	.	.	.	.
.	.	.	.	.	.	.	.
.	.	.	.	.	.	.	.
.	.	.	.	.	.	.	.
C <sub>n</sub>	Capacitor	1.1 $\mu$ F	Multilayer Ceramic Capacitors	1	CC0603KRX5R1A4 75K	ABC Co. Ltd.	C0402

FIG. 4

--Digitally Signed--  
**Bhanu Prasad**  
 (INPA No: 3253)  
 Head, IPR Dept.,  
 L&T Technology Services Limited,  
 DLF 3rd Block, 2nd Floor,  
 Manapakkam, Chennai - 600089.

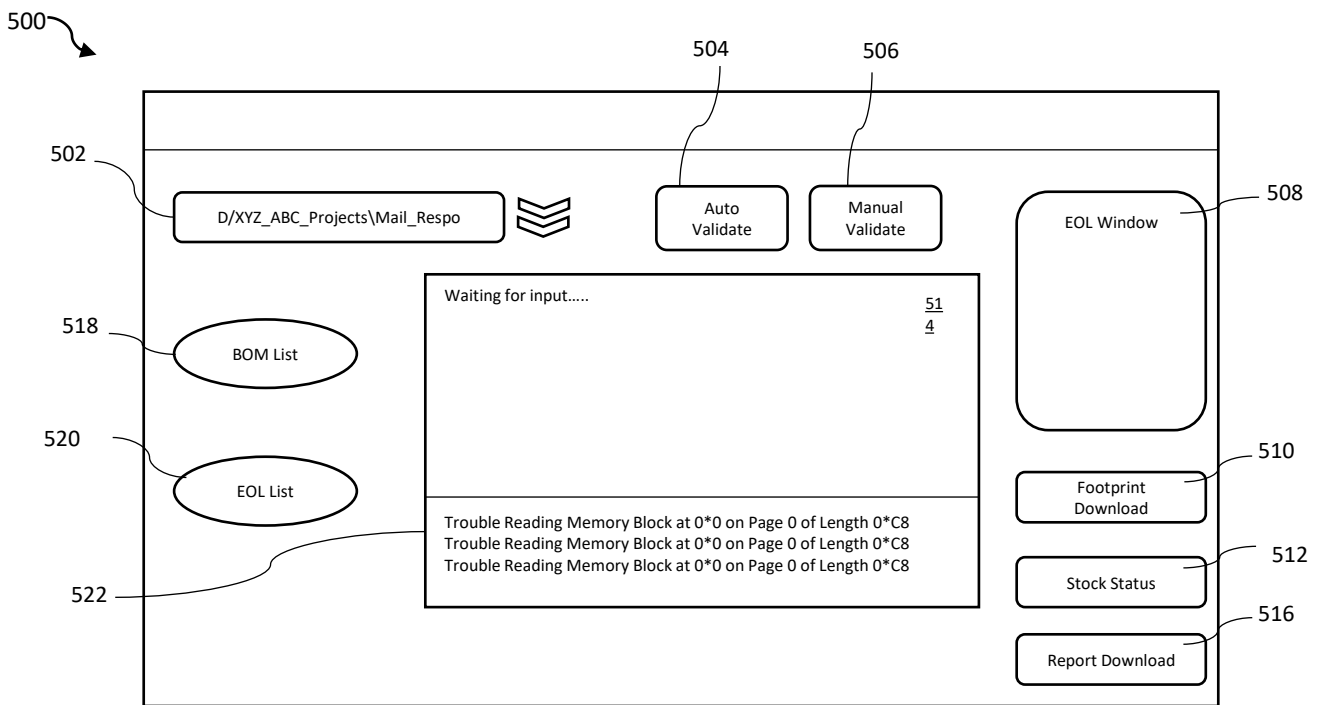

FIG. 5

--Digitally Signed--  
Bhanu Prasad  
(INPA No: 3253)  
Head, IPR Dept.,  
L&T Technology Services Limited,  
DLF 3rd Block, 2nd Floor,  
Manapakkam, Chennai - 600089.

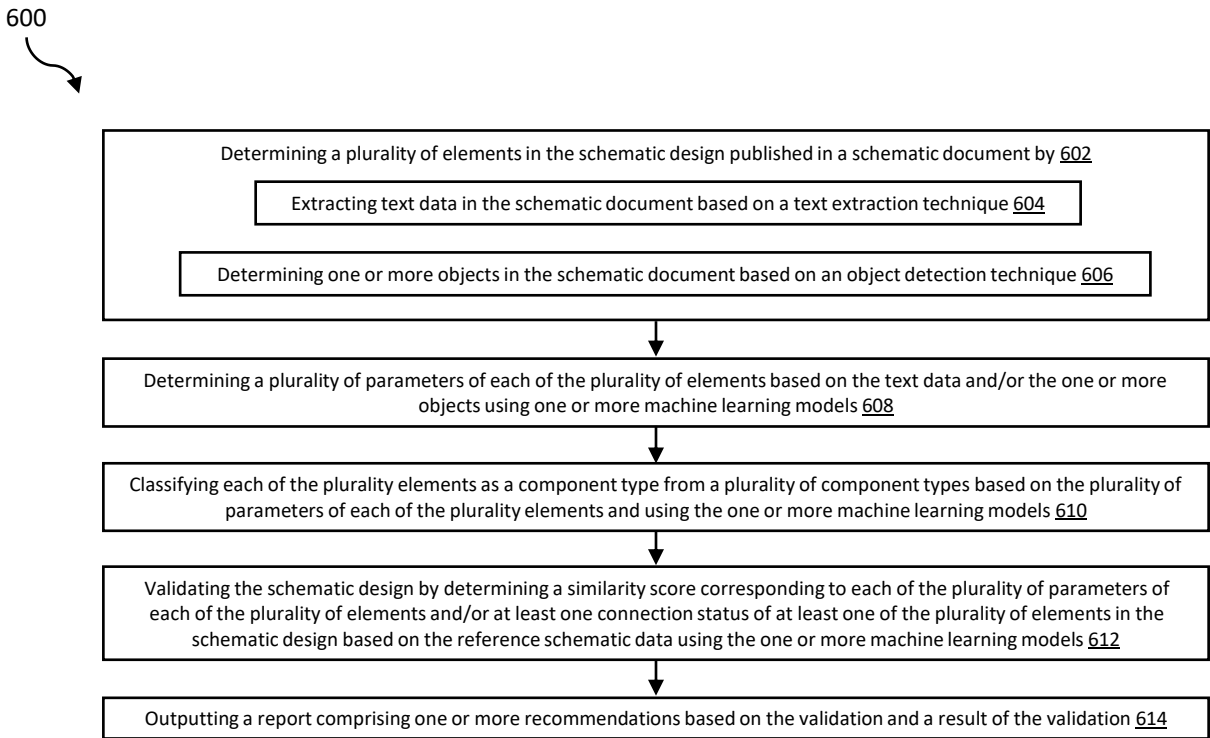

FIG. 6

--Digitally Signed--  
Bhanu Prasad  
(INPA No: 3253)  
Head, IPR Dept.,  
L&T Technology Services Limited,  
DLF 3rd Block, 2nd Floor,  
Manapakkam, Chennai - 600089.