

(12) Indian Patent Application

(21) Application Number: 202441003738

(22) Filing Date: 18/01/2024 (43) Publication Date: 25/07/2025

(71) Applicant(s): L&T TECHNOLOGY SERVICES LIMITED

(72) Inventor(s): Badnal, Shrishail
Bhargav, Nithish
Ramaiah, Umesh
Alakkad, Shamal

(51) International Classifications: G01R 1/067 B64C 25/00 H01Q 1/38 A61J 1/14 A61B 5/00

(54) Title: A MODULE OF A HAEMATOLOGY ANALYSER

(57) Abstract: A module (11) of a haematology analyser (1) configured to rotate a probe (12). The module comprises a base (13) having a first end (14) and a second end (15). A guide track (16) extending from the first end (14) of the base (13) and towards the second end (15) of the base (13). A guide block (22) configured to longitudinally slide over the guide track (16). A first block (24) mounted over the guide block (22); a second block (25) connected with the first block (24). A gear arrangement (37) secured in between the first block (24) and a second block (25), a third block (40) in connection with a second block (25) comprise the probe (12), wherein, the gear arrangement (37) is configured to rotate the probe (12) from a first position to a second position.

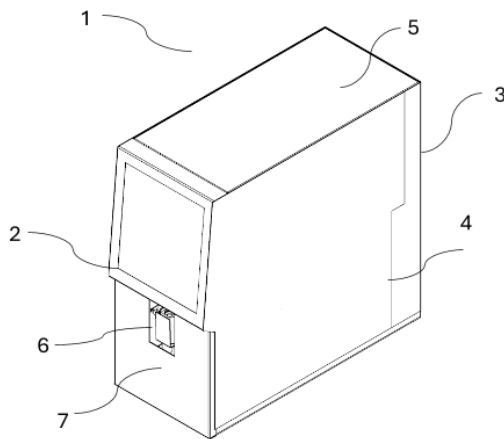

Figure 1

FORM 2

THE PATENTS ACT 1970
(39 OF 1970)

&

The Patent Rules, 2003

Complete Specification

(See Section 10 and Rule 13)

1. TITLE OF THE INVENTION

A MODULE OF A HAEMATOLOGY ANALYSER

2. APPLICANT(S)

(a) NAME : **L&T TECHNOLOGY SERVICES LIMITED**

(b) NATIONALITY : **INDIAN**

(c) ADDRESS : DLF IT SEZ Park, 2nd Floor – Block 3
1/124, Mount Poonamallee Road,
Ramapuram, Chennai – 600 089,
INDIA.

3. PREAMBLE TO THE DESCRIPTION

COMPLETE

The following specification particularly describes the invention and the manner in which it is
to be performed

TECHNICAL FIELD

[001] The present disclosure, in general, relates to the field of haematology analyser. Particularly, but not exclusively, the present disclosure relates to a module of a haematology analyser. Further, embodiments of the present disclosure relate to a module of a haematology analyser configured to rotate a probe.

BACKGROUND OF THE DISCLOSURE

[002] A haematology analyser is an instrument which is widely used in testing of physiological, chemical and physical properties of body fluid. The haematology analyser comprises a plurality of testing module such as CRP module, RBC module and WBC module. The sampling unit is also disposed close to the testing unit so that the sample is easily accessible to the testing unit.

15

[003] In the existing art it is seen that the sampling unit is positioned in the same side of the testing unit of the haematology analyser and due to this arrangement, a substantial width or space is required to accommodate all the testing module along with the sampling unit. The positioning of sampling unit along with the testing unit requires a lot of space and in case there is space constraint, then the haematology analyser known in the art may not be used. Also, there is a requirement to design a haematology analyser which utilizes the existing space and my not require additional space to mount the sampling unit.

20

[004] Thus, there is a need to provide a haematology analyser in order to overcome the above-mentioned problems. The present disclosure is directed to overcome one or more limitations stated above or any other limitations associated with the conventional configuration of the haematology analyser

25

SUMMARY OF THE DISCLOSURE

30

[005] One or more shortcomings of the prior art are overcome by haematology analyser as claimed and additional advantages are provided through the haematology analyser as claimed in the present disclosure. Additional features and advantages are realized through the

techniques of the present disclosure. Other embodiments and aspects of the disclosure are described in detail herein and are considered a part of the claimed disclosure.

5 [006] In one non-limiting embodiment of the present disclosure, a module of a haematology analyser configured to rotate a probe, wherein the module comprises a base having a first end and a second end, a guide track extending from the first end of the base and towards the second of the base; a guide block configured to longitudinally slide over the guide track; a first block mounted over the guide block; a second block connected with the first block; a gear arrangement secured in between the first block and a second block; a third block in connection
10 with a second block comprise the probe ; wherein, the gear arrangement is configured to rotate the probe from a first position to a second position.

[007] In an embodiment, a first stepper motor is connected with the first end of the base and is configured to longitudinally move the guide block over a guide shaft of the guide track.
15

[008] In an embodiment, the first block comprises a first top plate having a top cavity, a first bottom plate having a bottom cavity; a second stepper motor mounted on the top plate, the guide block positioned below the bottom plate wherein, a driving gear positioned on the first bottom plate and is connected with the second stepper motor, the second stepper motor is
20 configured to drive the driving gear.

[009] In an embodiment, the second block comprises a second top plate positioned beneath the first top plate and abuts with the first top plate, a second bottom plate positioned above the first bottom plate; a driven gear positioned on the second bottom plate wherein the driven gear
25 comprises a driven shaft extending from the driven gear and is secured in the top cavity and bottom cavity formed on the first block.

[010] In an embodiment, the gear arrangement comprises the driving gear secured in the first block and the driver gear secured in the second block wherein the driving gear drives and
30 rotates the driven gear.

[011] In an embodiment, the third block comprises a probe base connected with a side plate of the second block ; a third top plate connected with a first end of the probe base; a third stepper motor mounted on the third top plate; a probe base bottom holder connected with a

second end of the probe base; a plurality of guide shafts extending vertically from the third top plate and towards the probe base bottom holder; a probe holder disposed on the plurality of guide shafts and between the third top plate and the probe base bottom wherein the probe holder is configured to slide over the pluralities of guide shafts ; a probe secured with the probe holder and moves vertically between the third top plate and the probe base bottom wherein the probe is configured to aspirate a sample from a sample holder.

[012] In an embodiment, the third stepper motor is configured to move the probe holder in an upward and downward direction.

[013] In an embodiment, at the time of testing, the probe is configured to move in a downward direction by the third stepper motor and the probe aspirates the sample from the sample holder.

[014] In an embodiment, the aspirated probe moves upward by the third stepper motor.

[015] In an embodiment, the second stepper motor drives the driving gear, the driving gear drives and rotates the driven gear in a 90 degree and toward a testing unit.

[016] In an embodiment, the rotation of driven gear rotates the second block and rotation of second block rotates the third block towards the testing unit.

[017] In an embodiment, the first block slides over the guide track and the third block in connection with the first block by means of second block, the third block moves horizontally over the guide track.

[018] In an embodiment, the probe in connection with the third block moves horizontally and is accessed to the testing unit.

[019] In an embodiment, the testing unit comprises a CRP module, a RBC bath and a WBC bath

[020] In alternate non-limiting embodiment of the present disclosure, a haematology analyser configured to count the complete blood count. The haematology analyser comprises a front end and a rear end; a first side wall extending from the front end and towards the rear end ; a

sampling device disposed on a central portion of the front end of the haematology analyser comprises an opening to position a sample tube holder mechanism; a probe carriage mechanism disposed on the first side wall, the probe carriage mechanism comprises a testing unit to access a plurality of testing modules to count the complete blood count and a module which is
5 configured to rotate a probe wherein the module comprises a base having a first end and a second end ; a guide track extending from the first end of the base and towards the second of the base; a guide block configured to longitudinally slide over the guide track; a first block mounted over the guide block; a second block connected with the first block; a gear arrangement secured in between the first block and a second block; a third block in connection
10 with a second block comprise the probe ; wherein, the gear arrangement is configured to rotate the probe from a first position to a second position.

[021] The foregoing summary is illustrative only and is not intended to be in any way limiting. In addition to the illustrative aspects, embodiments, and features described above, further
15 aspects, embodiments, and features will become apparent by reference to the drawings and the following detailed description.

BRIEF DESCRIPTION OF THE ACCOMPANYING DRAWINGS

[022] The novel features and characteristics of the disclosure are set forth in the appended
20 claims. The disclosure itself, however, as well as a preferred mode of use, further objectives, and advantages thereof, will best be understood by reference to the following detailed description of an illustrative embodiment when read in conjunction with the accompanying figures. One or more embodiments are now described, by way of example only, with reference
25 to the accompanying figures wherein like reference numerals represent like elements and in which:

[023] Figure 1 illustrates a perspective view of the haematology analyser in accordance with
30 an embodiment of the present disclosure.

[024] Figure 2 illustrates a perspective view of the haematology analyser in accordance with
an embodiment of the present disclosure at second position.

[025] Figure 3 illustrates a zoomed view of portion encircled in figure 2.

35

[026] Figure 4 illustrates a perspective view of the probe along with one of the testing module in accordance with an embodiment of the present disclosure at second position.

[027] Figure 5 illustrates a zoomed view of portion encircled in figure 4.

5

[028] Figure 6 illustrates a front perspective view of a module of the haematology analyser in accordance with an embodiment of the present disclosure.

[029] Figure 7 illustrates a rear perspective view of a module of the haematology analyser in accordance with an embodiment of the present disclosure.

10

[030] Figure 8 illustrates a front perspective view of a first block and second block of the haematology analyser in accordance with an embodiment of the present disclosure.

[031] Figure 9 illustrates a zoomed view of portion encircled in figure 8.

15

[032] Figure 10 illustrates a front perspective view of a third block of the haematology analyser in accordance with an embodiment of the present disclosure.

[033] Figure 11 illustrates a zoomed view of portion encircled in figure 10.

20

[034] The figures depict embodiments of the disclosure for purposes of illustration only. One skilled in the art will readily recognize from the following description that alternative embodiments of the apparatus illustrated herein may be employed without departing from the principles of the disclosure described herein.

25

DETAILED DESCRIPTION

[035] While the embodiments in the disclosure are subject to various modifications and alternative forms, specific embodiments thereof have been shown by the way of example in the figures and will be described below. It should be understood, however that it is not intended to limit the disclosure to the particular forms disclosed, but on the contrary, the disclosure is to cover all modifications, equivalents, and alternative falling within the scope of the disclosure.

30

[036] Before describing detailed embodiments, it may be observed that the novelty and inventive step that are in accordance with the present disclosure resides in a haematology

35

analyser. However, such modification should be construed within the scope of the present disclosure. Accordingly, the drawings are showing only those specific details that are pertinent to understanding the embodiments of the present disclosure so as not to obscure the disclosure with details that will be readily apparent to those of ordinary skill in the art having benefit of the description herein.

[037] In the present disclosure, the term “exemplary” is used herein to mean “serving as an example, instance, or illustration.” Any embodiment or implementation of the present subject matter described herein as “exemplary” is not necessarily to be construed as preferred or advantageous over other embodiments.

[038] The terms “comprises”, “comprising”, or any other variations thereof used in the disclosure, are intended to cover non-exclusive inclusions, such that an apparatus, device, assembly, mechanism, system, and method that comprises a list of components does not include only those components but may include other components not expressly listed or inherent to such apparatus, system, assembly, or device. In other words, one or more elements in a system preceded by “comprises... a” does not, without more constraints, preclude the existence of other elements or additional elements in the system or apparatus or method.

[039] The terms like “at least one” and “one or more” may be used interchangeably or in combination throughout the description.

[040] Reference will now be made to the exemplary embodiments of the disclosure, as illustrated in the accompanying drawings. Wherever possible, same numerals will be used to refer to the same or like parts. Embodiments of the disclosure are described in the following paragraphs with reference to FIGS. 1 to 11. In FIGS. 1 to 11, the same element or elements which have same functions are indicated by the same reference signs.

[041] Embodiments of the present disclosure disclose a module of a haematology analyser configured to rotate a probe, wherein the module comprises a base having a first end and a second end, a guide track extending from the first end of the base and towards the second of the base; a guide block configured to longitudinally slide over the guide track; a first block mounted over the guide block; a second block connected with the first block; a gear arrangement secured in between the first block and a second block; a third block in connection

with a second block comprise the probe ; wherein, the gear arrangement is configured to rotate the probe from a first position to a second position.

5 [042] In an alternate embodiment, a haematology analyser configured to count the complete blood count. The haematology analyser comprises a front end and a rear end; a first side wall extending from the front end and towards the rear end ; a sampling device disposed on a central portion of the front end of the haematology analyser comprises an opening to position a sample tube holder mechanism; a probe carriage mechanism disposed on the first side wall, the probe carriage mechanism comprises a testing unit to access a plurality of testing modules to count
10 the complete blood count and a module which is configured to rotate a probe wherein the module comprises a base having a first end and a second end ; a guide track extending from the first end of the base and towards the second of the base; a guide block configured to longitudinally slide over the guide track; a first block mounted over the guide block; a second block connected with the first block; a gear arrangement secured in between the first block
15 and a second block; a third block in connection with a second block comprise the probe ; wherein, the gear arrangement is configured to rotate the probe from a first position to a second position.

20 [043] The term ‘haematology analyser’ and ‘analyser ’ are used interchangeably used throughout the description. Although the module of the haematology analyser is described in the context of a haematology analyser such description is not intended to limit the disclosure to the particular forms disclosed, but on the contrary, the disclosure is to cover all modifications, equivalents, and alternative falling within the scope of the disclosure.
25 Accordingly, it is to be understood by a person skilled in the art that the system of the present disclosure may be employed in other apparatus, and machine, that has similar strength and operational requirements and that which requires similar constructional characteristics.

[044] The disclosure is described in the following paragraphs with reference to Figures 1 to
30 11 In the figures, the same element or elements which have same functions are indicated by the same reference signs. It is to be noted that, the entire set up of the haematology analyser including mounting or coupling arrangements used for mounting/coupling the haematology analyser s not illustrated in the figures in detail for the purpose of simplicity.

[045] Figure 1 illustrates a haematology analyser (1) in accordance with the embodiment of the present disclosure. The haematology analyser is configured to count the complete blood count. As shown in figure 1, the haematology analyser comprises a front end (2), a rear end (3), a first side wall (4) extending from the front end and towards the rear end and a top end (5) encloses the haematology analyser from the top and forming a closed body. A sampling device (6) is disposed on a central portion (7) of the front end of the haematology analyser. The sampling device comprises an opening to position a sample tube holder mechanism so that the sample tube is placed inside the sample tube holder mechanism.

10 [046] In embodiment of the present disclosure, a probe carriage mechanism (8) disposed on the first side wall. The probe carriage mechanism (8) comprises a testing unit (9) to access a plurality of testing modules (10) to count the complete blood count and a module (11) which is configured to rotate a probe (12). In the present disclosure, the sampling device is disposed on the central portion of the haematology analyser and the testing unit is present on the first side wall. The module of the probe carriage mechanism is configured to move the sample from the sampling device and towards the testing unit in order to count the complete blood count as illustrated in figures 2-5. As shown in figure 3, the probe access to CRP module (13), RBC bath (14) and WBC bath (15) located at the right side of the haematology analyser with help of the module where left and right along with up and down movement is possible.

20 [047] As shown in figure 6, the module comprises a base (13). The base provides a rigid support to the different components of the module. The base is having a first end (14) and a second end (15). A guide track (16) extends from the first end of the base and towards the second of the base. The guide track comprises a timing belt (17) over which a driver pulley (18) and a driver pulley (19) is mounted. The driver pulley is driven by a first stepper motor (20). The power from the driven pulley is transmitted to the driver pulley through the timing belt. The driver pulley rotates by receiving rotational force from the first stepper motor. The rotation of driver pulley moves the timing belt longitudinally which in turn drives the driven pulley. As shown in figure 6, the first stepper motor is connected with the first end of the base.

30 The guide track also comprises a guide shaft (21) which is disposed between the first end of the base and the second end of the base. The movement of the timing belt drives the guide shaft longitudinally. A guide block (22) is connected with the guide shaft and the guide block is configured to longitudinally slide over the guide track. The guide block comprises a hole (23) through which the guide shaft passes through and the movement of the guide shaft

longitudinally moves the guide shaft over the guide shaft. The first stepper motor is configured to longitudinally moves the guide block over a guide shaft of the guide track. The guide block longitudinally moves between the first end of the base and second end of the base. As shown in figure 7, a plurality of grooves (52) is present through which the guide shaft (21) made of stainless-steel passes through. The shafts are covered by self-lubricated material to provide the smooth movement of the guide block (22).

[048] In an embodiment and as shown in figure 6, 8 and 9, the module comprises a first block (24) and a second block (25). The first block is mounted over the guide block and the second block is connected with the first block. The first block comprises a first top plate (26) having a top cavity (27) and a first bottom plate (28) having a bottom cavity (29). In an embodiment, a second stepper motor (30) is mounted on the top plate and the guide block positioned below the bottom plate. A driving gear (31) is positioned on the first bottom plate and is connected with the second stepper motor by means of a first shaft (32) and the second stepper motor is configured to drive the driving gear. The stepper motor through the first shaft rotates the driving gear. The second block comprises a second top plate (33) positioned beneath the first top plate and abuts with the first top plate of the first block. The second block comprises a second bottom plate (34) positioned above the first bottom plate. A driven gear (35) positioned on the second bottom plate. The driven gear comprises a driven shaft (36) or second shaft extending from the driven gear and is secured in the top cavity of the first block and bottom cavity of the first block. Due to this connection, the first block is connected with the second block and a gear arrangement (37) is secured in between the first block and a second block. As shown in figure 9, the driver gear teeth (38) is properly meshed with the driven gear teeth (39). The gear arrangement comprises the driving gear secured in the first block and the driver gear secured in the second block wherein the driving gear drives and rotates the driven gear. During working of the analyser, the first stepper motor drives the driver gear which in turns drives the driven gear.

[049] In an embodiment and as shown in figure 7, 10 and 11, the module comprises a third block (40) which is in connection with the second block. The third block comprises a probe base (41) connected with a side plate (42) of the second block. The probe base of the third block is fastened with the side plate by means of fasteners and rigidity connected with the second block of the module. The probe base comprises a first end (43), a second end (44) and a flat central plate (45) positioned between the first end of the probe base and the second end

of the probe base. The central plate is having a pluralities of hole (46) through which the fasteners passes through and connects with the side plate of the second block. The third block comprises a third top plate (47) connected with a first end of the probe base. In an embodiment, a third stepper motor (48) is mounted on the third top plate.

5

[050] The third block comprises a probe base bottom holder (49) connected with the second end of the probe base and a plurality of guide shafts (50) extending vertically from the third top plate and towards the probe base bottom holder. A probe holder (51) is disposed on the plurality of guide shafts and between the third top plate and the probe base bottom holder. The probe holder is configured to slide over the pluralities of guide shafts. In an embodiment, a probe (12) is secured with the probe holder and moves vertically between the third top plate and the probe base bottom holder. The probe is configured to aspirate a sample from a sample holder and the gear arrangement is configured to rotate the probe from a first position to a second position. The first position is the position when the probe is at its initial position i.e. facing the central portion of the analyser and the second position is the position when the probe is at its final position i.e. close to the testing module facing the first side portion of the analyser.

10

[051] In an embodiment, the third stepper motor is configured to move the probe holder in an upward and downward direction. At the time of testing, the probe is configured to move in a downward direction by the third stepper motor and the probe aspirates the sample from the sample holder and the aspirated probe moves upward by the third stepper motor. The second stepper motor drives the driving gear, the driving gear drives and rotates the driven gear in a 90 degree and toward a testing unit. The rotation of driven gear rotates the second block and rotation of second block rotates the third block towards the testing unit. The first block slides over the guide track and the third block in connection with the first block by means of second block, the third block moves horizontally over the guide track. The probe in connection with the third block moves horizontally and is accessed to the testing unit. In an embodiment, the testing unit comprises a CRP module, a RBC bath and a WBC bath.

20

25

[052] The various embodiments of the present disclosure have been described above with reference to the accompanying drawings. The present disclosure is not limited to the illustrated embodiments; rather, these embodiments are intended to fully and completely disclose the subject matter of the disclosure to those skilled in this art. In the drawings, like numbers refer

30

to like elements throughout. Thicknesses and dimensions of some components may be exaggerated for clarity.

5 [053] Herein, the terms “attached”, “connected”, “interconnected”, “contacting”, “mounted”, “coupled” and the like can mean either direct or indirect attachment or contact between elements, unless stated otherwise.

10 [054] Well-known functions or constructions may not be described in detail for brevity and/or clarity. As used herein the expression “and/or” includes any and all combinations of one or more of the associated listed items.

15 [055] The terminology used herein is for the purpose of describing particular embodiments only and is not intended to be limiting of the disclosure. As used herein, the singular forms “a”, “an” and “the” are intended to include the plural forms as well, unless the context clearly indicates otherwise. It will be further understood that the terms “comprises”, “comprising”, “includes” and/or “including” when used in this specification, specify the presence of stated features, operations, elements, and/or components, but do not preclude the presence or addition of one or more other features, operations, elements, components, and/or groups thereof.

WE CLAIM:

1. A module (11) of a haematology analyser (1) configured to rotate a probe (12), wherein the module comprises:

a base (13) having a first end (14) and a second end (15) ;

a guide track (16) extending from the first end (14) of the base (13) and towards the second end (15) of the base (13);

a guide block (22) configured to longitudinally slide over the guide track (16);

a first block (24) mounted over the guide block (22);

a second block (25) connected with the first block (24);

a gear arrangement (37) secured in between the first block (24) and a second block (25);

a third block (40) in connection with a second block (25) comprise the probe (12);

wherein, the gear arrangement (37) is configured to rotate the probe (12) from a first position to a second position.

2. The module of a haematology analyser as claimed in claim 1, wherein a first stepper motor (20) is connected with the first end (14) of the base (13) and is configured to longitudinally move the guide block (22) over a guide shaft (21) of the guide track (16).

3. The module of a haematology analyser as claimed in claim 1, wherein the first block (24) comprises :

a first top plate (26) having a top cavity (27) ;

a first bottom plate (28) having a bottom cavity (29);

a second stepper motor (30) mounted on the first top plate (26);

the guide block (22) positioned below the first bottom plate (28) wherein,

a driving gear (31) positioned on the first bottom plate (28) and is connected with the second stepper motor (30), the second stepper motor (30) is configured to drive the driving gear (31).

4. The module of a haematology analyser as claimed in claim 1, wherein the second block (25) comprises :

a second top plate (33) positioned beneath the first top plate (26) and abuts with the first top plate (26);

a second bottom plate (34) positioned above the first bottom plate (28);

a driven gear (35) positioned on the second bottom plate (34) wherein the driven gear (35) comprises a driven shaft (36) extending from the driven gear (35) and is secured in the top cavity (27) and bottom cavity (29) formed on the first block (24).

5. The module of a haematology analyser as claimed in claim 1, wherein the gear arrangement (37) comprises the driving gear (31) secured in the first block (24) and the driven gear (35) secured in the second block (25) wherein the driving gear (31) drives and rotates the driven gear (35).

6. The module of a haematology analyser as claimed in claim 1, wherein the third block (40) comprises :

a probe base (41) connected with a side plate (42) of the second block (25) ;

a third top plate (47) connected with a first end (43) of the probe base (41);

a third stepper motor (48) mounted on the third top plate (47);

a probe base bottom holder (49) connected with a second end (44) of the probe base (41);

a plurality of guide shafts (50) extending vertically from the third top plate (47) and towards the probe base bottom holder (49);

a probe holder (51) disposed on the plurality of guide shafts (50) and between the third top plate (47) and the probe base bottom holder (49) wherein the probe holder (51) is configured to slide over the pluralities of guide shafts (50) ;

a probe (12) secured with the probe holder (51) and moves vertically between the third top plate (47) and the probe base bottom holder (49) wherein the probe (12) is configured to aspirate a sample from a sample holder (6).

7. The module of a haematology analyser as claimed in claim 1, wherein the third stepper motor (48) is configured to move the probe holder (51) in an upward and downward direction.

8. The module of a haematology analyser as claimed in claim 1, wherein at the time of testing, the probe (12) is configured to move in a downward direction by the third stepper motor (48) and the probe aspirates the sample from the sample holder (6) .

9. The module of a haematology analyser as claimed in claim 8, wherein the aspirated probe moves upward by the third stepper motor (48).

10. The module of a haematology analyser as claimed in claims 1-9, wherein the second stepper motor (30) drives the driving gear (31), the driving gear (31) drives and rotates the driven gear (35) in a 90 degree and toward a testing unit (9).

11. The module of a haematology analyser as claimed in claims 1-10, wherein the rotation of driven gear (35) rotates the second block (25) and rotation of second block (25) rotates the third block (40) towards the testing unit (9).

12. The module of a haematology analyser as claimed in claims 1-11, wherein the first block (24) slides over the guide track (16) and the third block (40) in connection with the first block (24) by means of second block (25), the third block (40) moves horizontally over the guide track (16).

13. The module of a haematology analyser as claimed in claims 1-12, wherein the probe (12) in connection with the third block (40) moves horizontally and is accessed to the testing unit (9).

14. The module of a haematology analyser as claimed in claims 1-12, wherein the testing unit (9) comprises a CRP module (13), a RBC bath (14) and a WBC bath (15).

15. A haematology analyser (1) configured to count the complete blood count, the haematology analyser (1) comprises:

a front end (2) and a rear end (3);

a first side wall (4) extending from the front end (2) and towards the rear end (3);

a sampling device (6) disposed on a central portion (7) of the front end (2) of the haematology analyser (1) comprises an opening to position a sample tube holder mechanism;

a probe carriage mechanism (8) disposed on the first side wall (4), the probe carriage mechanism (8) comprises a testing unit (9) to access a plurality of testing modules (10) to count the complete blood count and a module (11) which is configured to rotate a probe (12) wherein the module (11) comprises :

a base (13) having a first end (14) and a second end (15);

a guide track (16) extending from the first end (14) of the base (13) and towards the second end (15) of the base (13);

a guide block (22) configured to longitudinally slide over the guide track (16);

a first block (24) mounted over the guide block (22);
a second block (25) connected with the first block (24);
a gear arrangement (37) secured in between the first block (24) and a second block (25);
a third block (40) in connection with a second block (25) comprise the probe (12); wherein, the gear arrangement (37) is configured to rotate the probe (12) from a first position to a second position.

Dated this 18th day of January 2024

--Digitally Signed--
Bhanu Prasad (INPA No: 3253)
Head, IPR Dept.,
L&T Technology Services Limited,
DLF 3rd Block, 2nd Floor,
Manapakkam, Chennai, TN, 600089.

ABSTRACT

A MODULE OF A HAEMATOLOGY ANALYSER

A module (11) of a haematology analyser (1) configured to rotate a probe (12). The module comprises a base (13) having a first end (14) and a second end (15). A guide track (16) extending from the first end (14) of the base (13) and towards the second end (15) of the base (13). A guide block (22) configured to longitudinally slide over the guide track (16). A first block (24) mounted over the guide block (22);

a second block (25) connected with the first block (24). A gear arrangement (37) secured in between the first block (24) and a second block (25), a third block (40) in connection with a second block (25) comprise the probe (12), wherein, the gear arrangement (37) is configured to rotate the probe (12) from a first position to a second position.

[Figure 6 is representative figure].

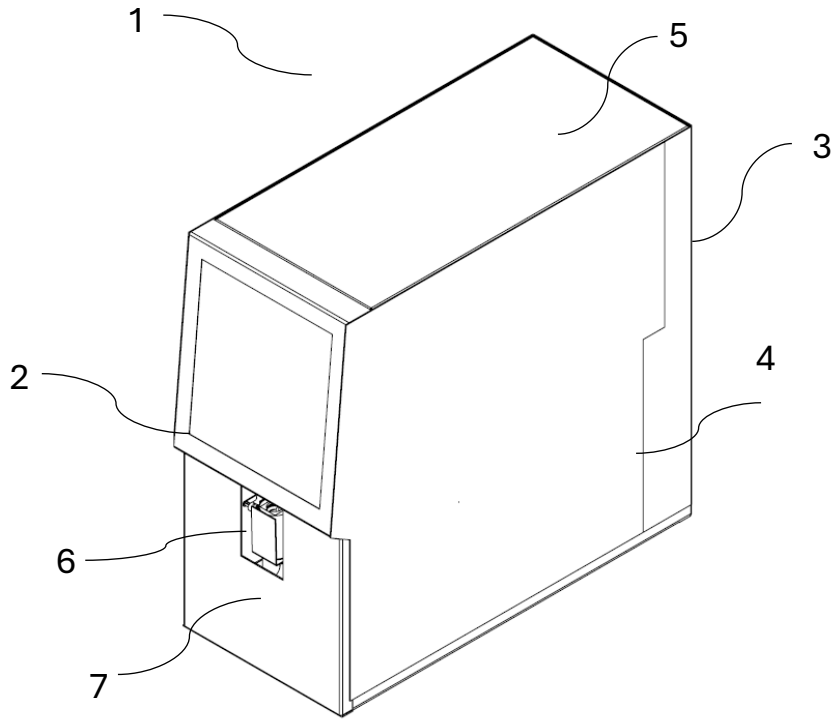

Figure 1

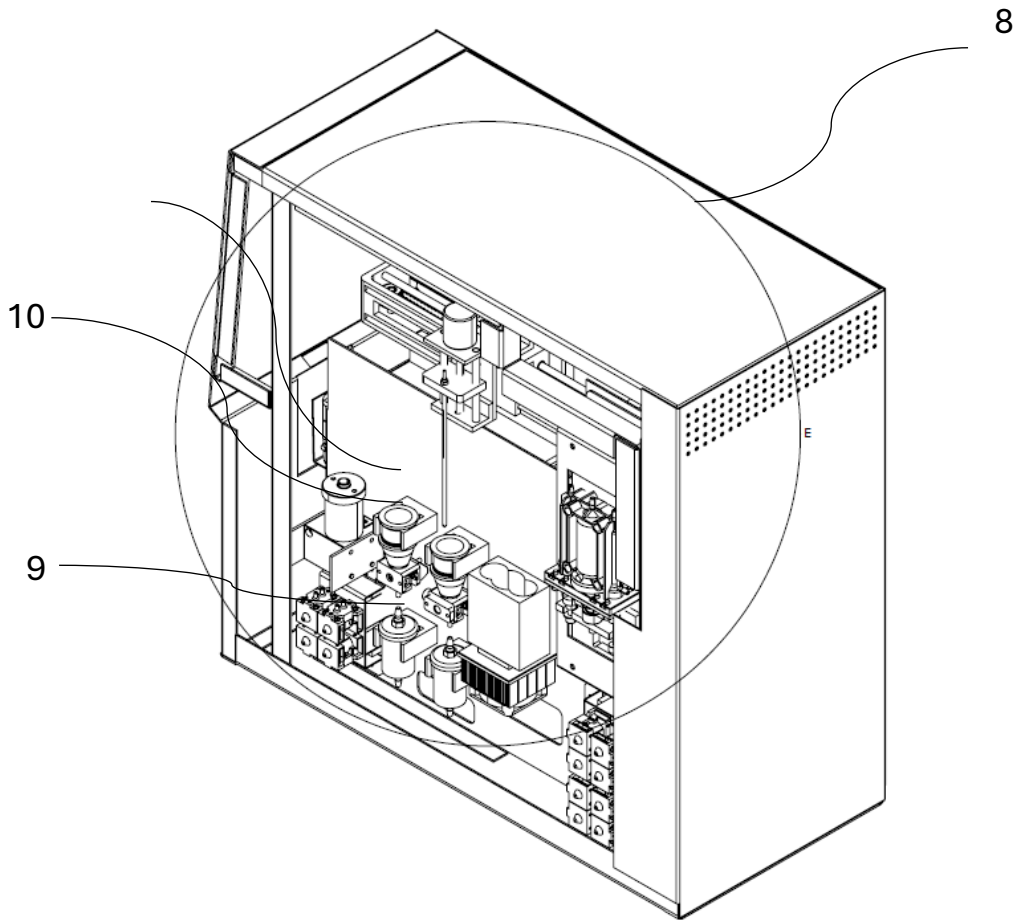

Figure 2

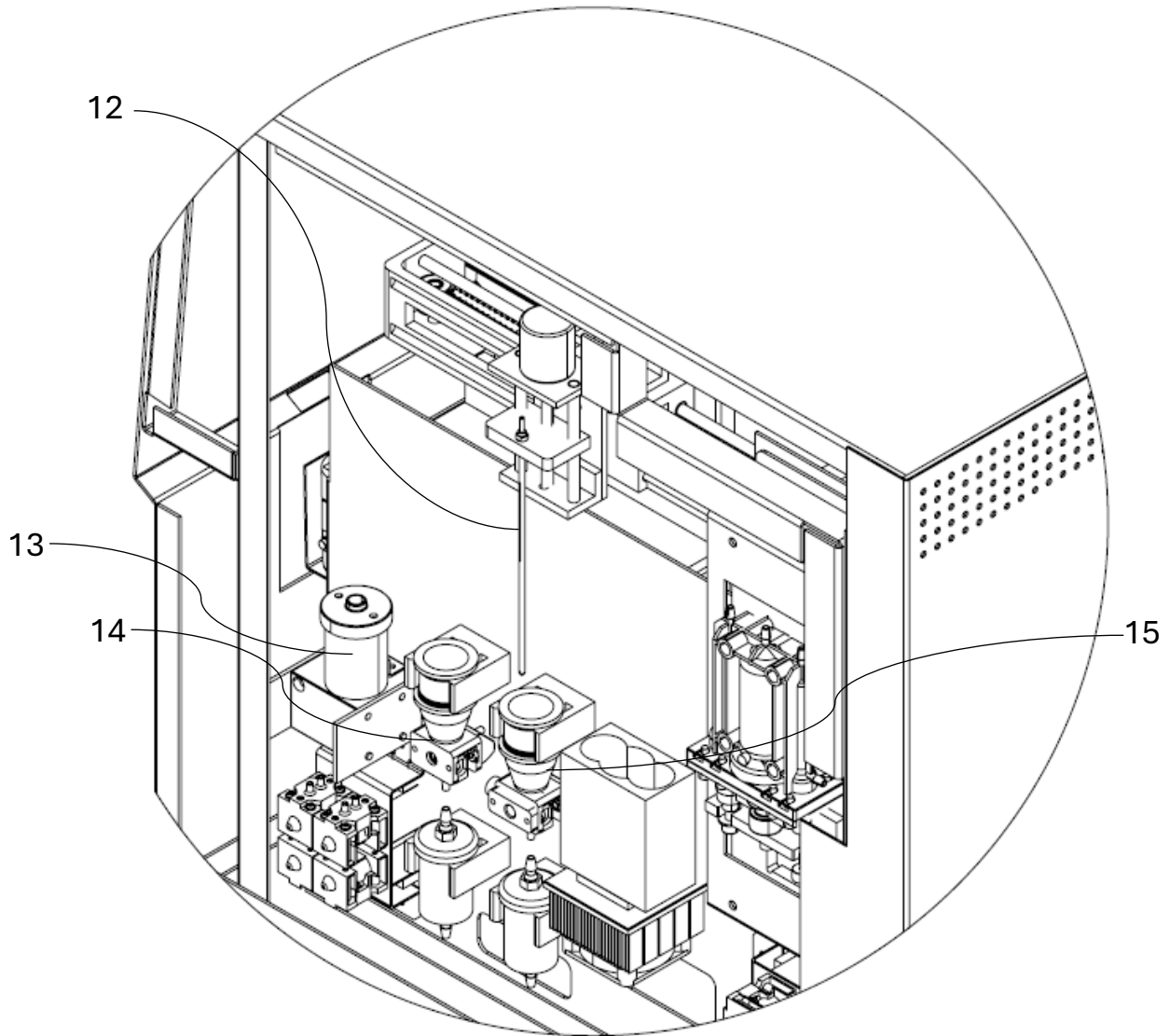

Figure 3

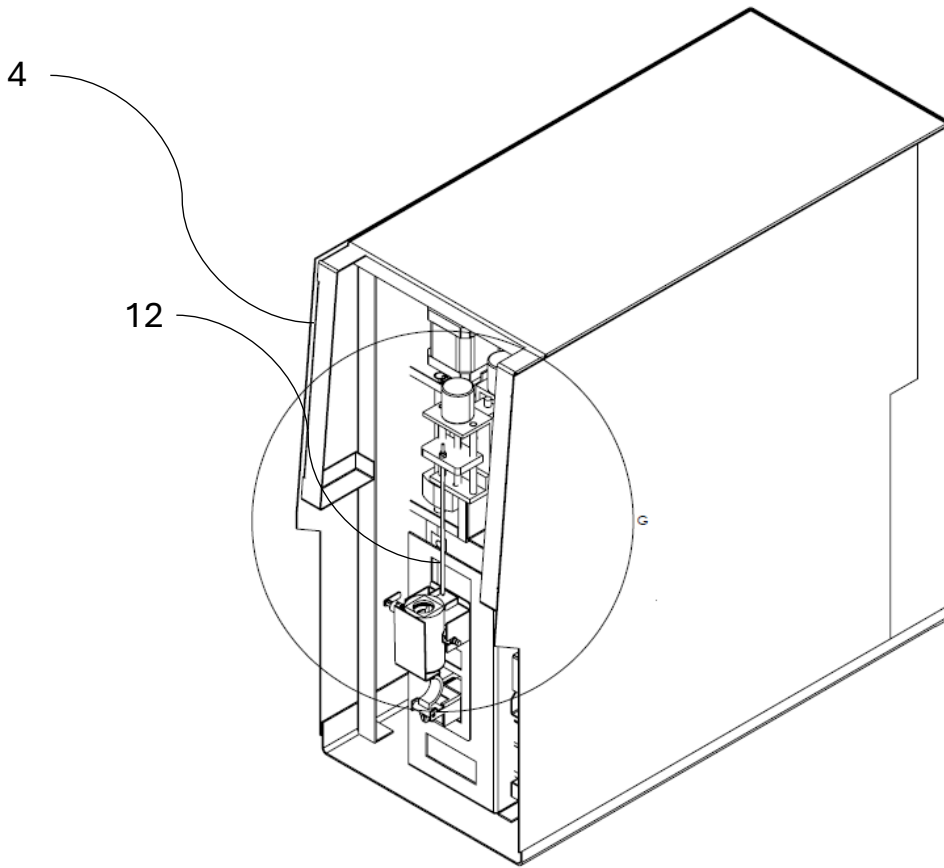

Figure 4

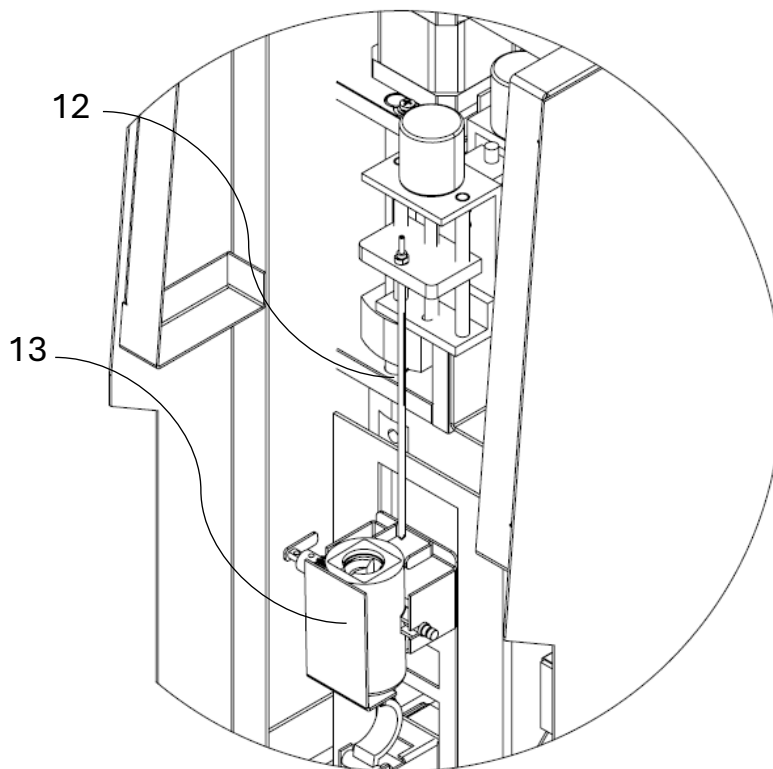

Figure 5

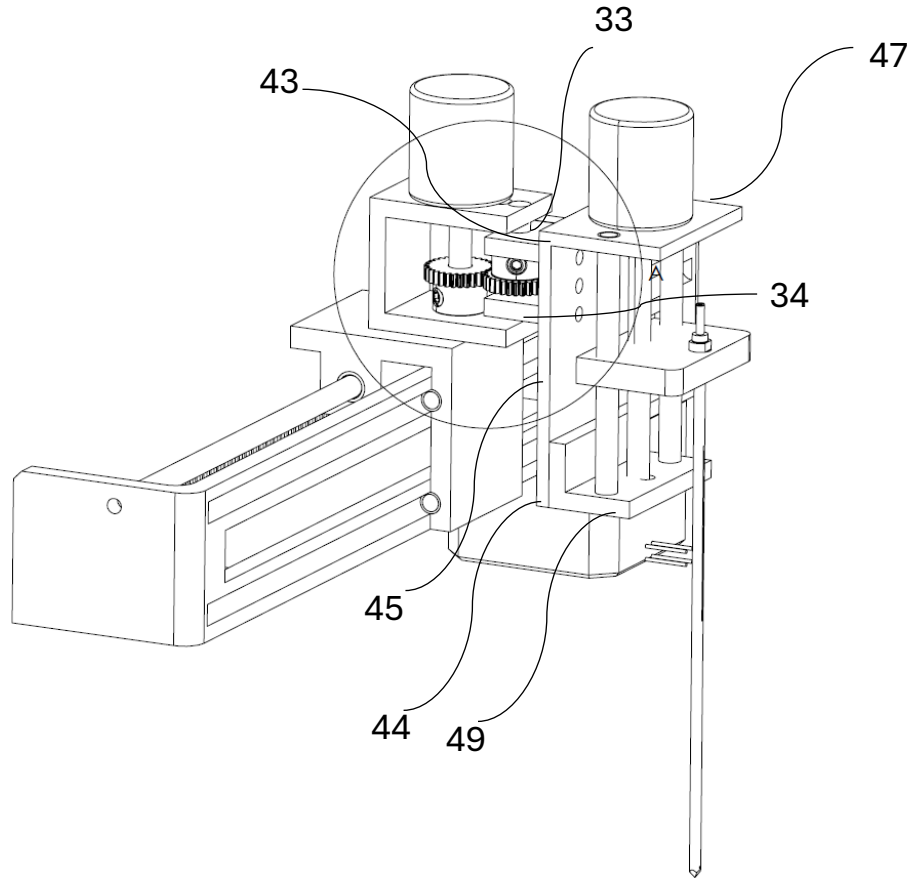

Figure 8

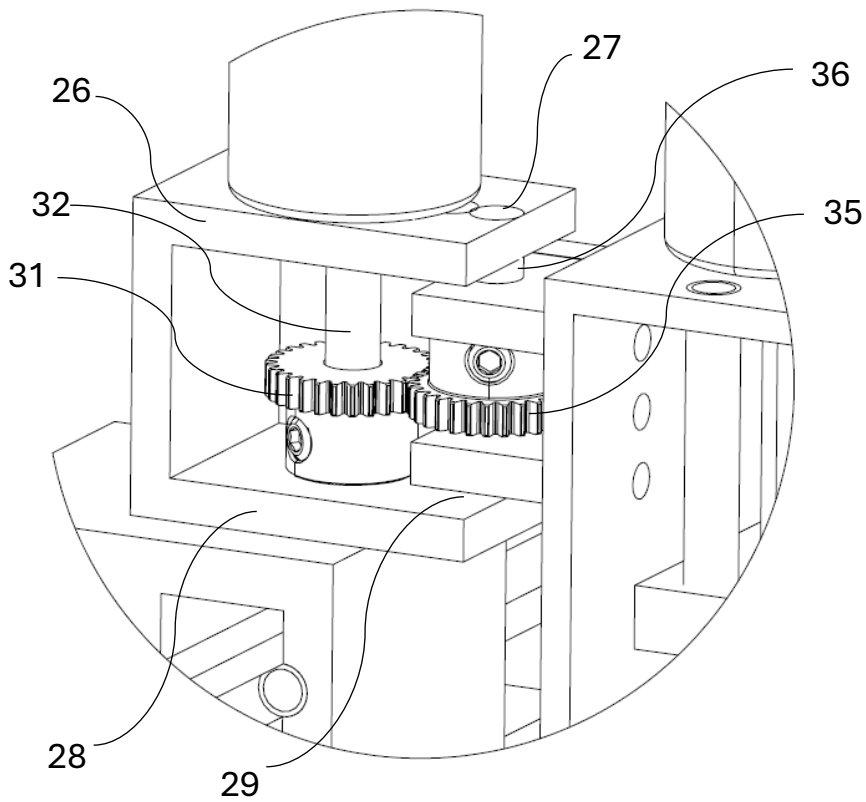

Figure 9

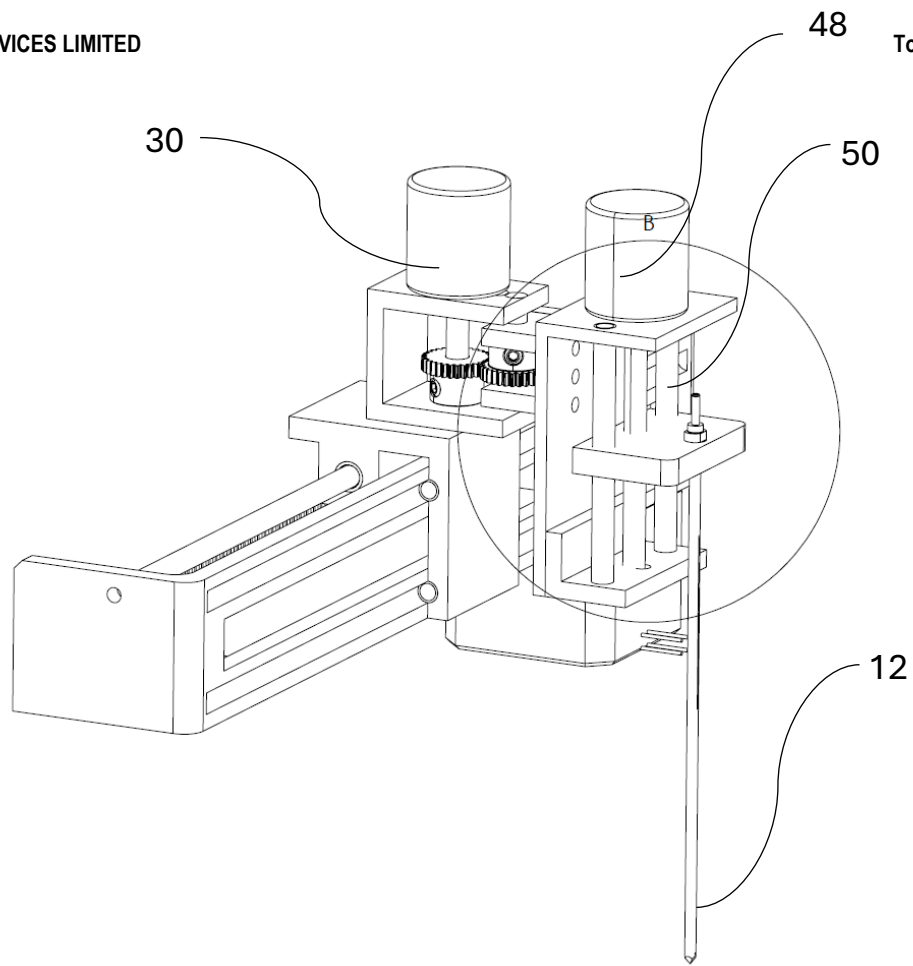

Figure 10

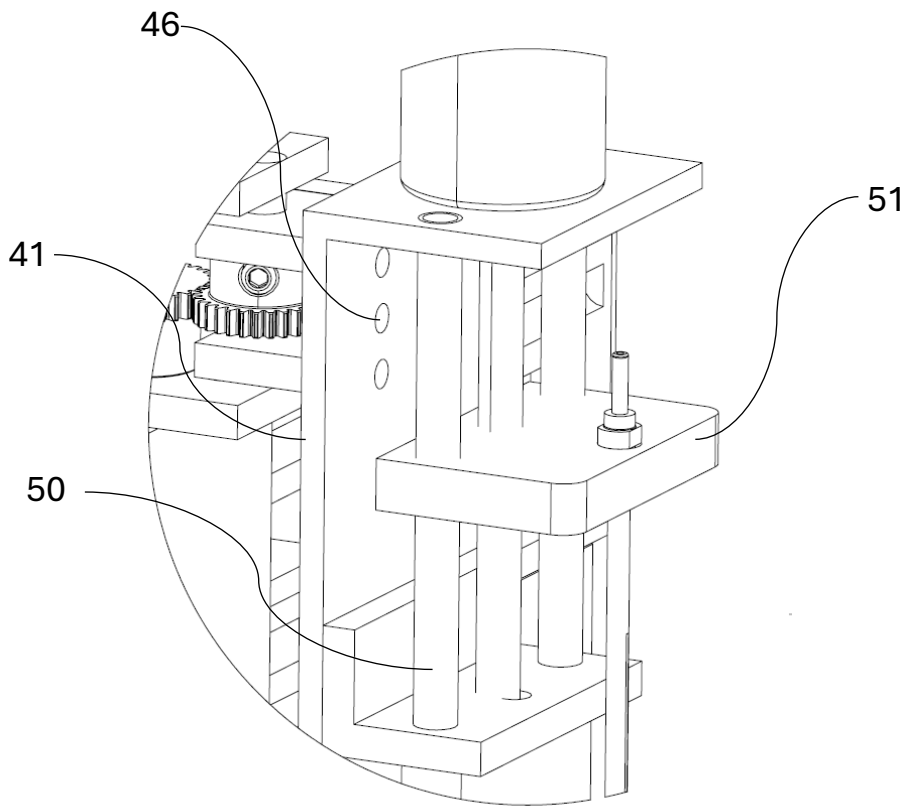

Figure 11