

(12) Indian Patent Application

(21) Application Number: 202441006251

(22) Filing Date: 30/01/2024 (43) Publication Date: 01/08/2025

(71) Applicant(s): L&T TECHNOLOGY SERVICES LIMITED

(72) Inventor(s): Sethuraj, Rammohan

(51) International Classifications: F25D 11/02 F25D 17/06 F25D 17/04 F25D 25/02 B64D 13/08

(54) Title: AN AIR PASSAGE DUCT ARRANGEMENT FOR A COMPARTMENTALIZED REFRIGERATOR

(57) Abstract: An air passage duct arrangement for a compartmentalized refrigerator comprising a supply duct, fluidly connecting a freezer compartment and a fridge compartment and configured to direct cold air from the freezer compartment to the fridge compartment. A return duct is fluidly connected to the freezer compartment and the fridge compartment being configured to direct a hot air from the fridge compartment to the freezer compartment. Further, a bypass duct interconnects the supply duct and the return duct. The air passage duct arrangement also includes a damper assembly, configured in the supply duct, the return duct and the bypass duct. The damper assembly is configured to be operated between a bypass position and an open position based on a condition of a door of the fridge compartment, to selectively restrict ingress of the hot air from the fridge compartment to the freezer compartment.

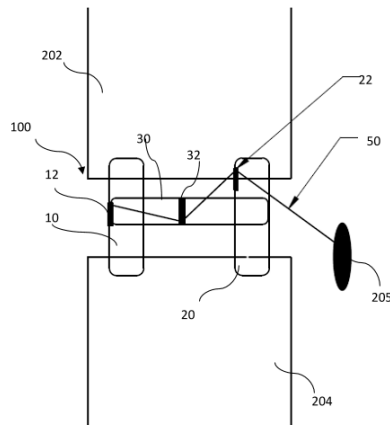

Fig.1

FORM 2

THE PATENTS ACT 1970
(39 OF 1970)
&
The Patent Rules, 2003

Complete Specification (See Section 10 and Rule 13)

1. TITLE OF THE INVENTION

**AN AIR PASSAGE DUCT ARRANGEMENT FOR A COMPARTMENTALIZED
REFRIGERATOR**

2. APPLICANT(S)

(a) NAME : **L&T TECHNOLOGY SERVICES LIMITED**

(b) NATIONALITY : **INDIAN**

(c) ADDRESS : DLF IT SEZ Park, 2nd Floor – Block 3

1/124, Mount Poonamallee Road,

Ramapuram, Chennai – 600 089,

INDIA.

3. PREAMBLE TO THE DESCRIPTION

COMPLETE

The following specification particularly describes the invention and the manner in which it is
to be performed

DESCRIPTION

Technical Field

[001] This disclosure relates generally to refrigerators, and more particularly to an air passage duct arrangement for a compartmentalized refrigerator.

5

BACKGROUND

[002] Typically, a refrigerator is an apparatus configured to store foods fresh by having a storage compartment for storing foods and a cooling energy supplying device for supplying a cooling energy to the storage compartment. A refrigerator may be provided with a refrigeration compartment and a freezing compartment. Usually, the freezing compartment is maintained at temperatures lower than the refrigeration compartment, and mainly used for ice making. Thus, the freezing compartment requires additional time and energy to maintain lower temperatures or lower than freezing temperatures, thereby adding load on to a compressor of the refrigerator.

[003] In general, the freezing compartment is configured above or below the refrigeration compartment. Each of the freezing compartments and refrigeration compartment can be accessed by a door. Further, these compartments are fluidly connected via at least one air supply duct and return duct configured to circulate air to maintain required temperatures. In an example, the refrigeration compartment is opened/closed by a refrigeration compartment door which is pivotally connected to a body of a refrigerator. During, opening and closing of the refrigeration compartment door, air enters into the refrigeration compartment, thus varying i.e., increasing the temperature within the compartment. As the air tends to transfer from higher pressure region to low pressure region, the air entered in refrigeration compartment increases pressure within the refrigeration compartment causing the air to enter into the freezer compartment via at least one supply duct. This results in increasing the temperature and pressure within the freezer compartment than a pre-set temperature and pressure. Moreover, due to rapid air flow a freezer compartment door may open. Therefore, the operation of compressors rapidly increases, consuming additional power to attain the preset temperature and pressure within the freezer compartment as well as in the refrigeration compartment.

[004] Typically, dampers are arranged within the supply and return duct to selectively control the air supply within the freezer and refrigeration compartment. However, during rapid closing and opening of the refrigeration compartment door the air flow is rapid

and leads to sudden rise in the pressure, thereby causing the damper to open from a closed position.

5 [005] Thus, the conventional damper arrangement lacks selective supply of air flow, leading to increased temperature in freezer compartment and energy consumption by the compressor which is not desirable. Additionally, an efficiency and operating temperature of the refrigerator deteriorates if the compressor is subjected to continuous operation at full capacity.

SUMMARY OF THE INVENTION

10 [006] In an embodiment, an air passage duct arrangement for a compartmentalized refrigerator comprising at least a freezer compartment and a fridge compartment. The air passage duct arrangement comprises a supply duct, fluidly connecting the freezer compartment and the fridge compartment. The supply duct is configured to direct cold air from the freezer compartment to the fridge compartment.

15 A return duct is fluidly connected to the freezer compartment and the fridge compartment. The return duct is being configured to direct a hot air from the fridge compartment to the freezer compartment. Further, a bypass duct interconnects the supply duct and the return duct. The air passage duct arrangement also includes a damper assembly, configured in the supply duct, the return duct and the bypass duct. The damper assembly is configured to be operated between a bypass position and an open position based on a condition of a door of the fridge compartment,
20 to selectively restrict ingress of the hot air from the fridge compartment to the freezer compartment.

[007] In an embodiment, the damper assembly includes a plurality of dampers comprising a first damper configured in the supply duct, a second damper configured in the return duct, and a third damper configured in the bypass duct.

25 [008] In an embodiment, the first damper and the second damper are configured to close the supply duct and the return duct. The third damper is configured open the bypass duct, in the bypass position of the damper assembly, when the door is in an open condition to restrict ingress of the hot air into the freezer compartment.

30 [009] In an embodiment, the first damper and the second damper are configured to close the supply duct and the return duct, and the third damper is configured open the bypass duct, in the bypass position of the damper assembly, when the door is in an open condition to restrict ingress of the hot air into the freezer compartment.

[010] In an embodiment, the first damper and the second damper are configured to open the supply duct and the return duct, and the third damper is configured to open the bypass duct, in the open position of the damper assembly, when the door is in a closed condition to supply the cold air into fridge compartment and direct the hot air into the freezer compartment.

5 [011] In an embodiment, each damper of the plurality of dampers is interconnected by a linkage mechanism. In an embodiment, the linkage mechanism is coupled with the door of the fridge compartment and being configured to operate the plurality of dampers between the bypass position and the open position based on operation of the door of the fridge compartment between open condition and closed condition.

10 [012] In an embodiment, each of the plurality of dampers is connected to at least one actuator. In an embodiment, the at least one actuator is coupled to the door of the fridge compartment and being configured to operate the plurality of dampers between the bypass position and an open position based on operation of the door of the fridge compartment between open condition and closed condition.

15 [013] In an embodiment, the air passage duct arrangement comprises a controller connected to at least one actuator and a power source, wherein the controller is configured to trigger the actuator to operate the plurality of dampers between the bypass position and an open position based on operation of the door of the fridge compartment between open condition and closed condition.

20 [014] In an embodiment, the air passage duct arrangement comprises at least one sensor provided to the door, wherein the at least one sensor is communicatively coupled to the controller to detect at least one of the open condition and closed condition of the door and operate the plurality of dampers between the bypass position and the open position.

25 [015] In an embodiment, the bypass duct interconnects an intermediate portion of the supply duct and return duct.

[016] The present disclosure also discloses a compartmentalized refrigerator comprising a refrigerator body defining an inner space opened or closed by refrigerator doors, the inner space defining at least a freezer compartment and a fridge compartment, fluidly connected to the freezer compartment by an air passage duct arrangement.

30 **BRIEF DESCRIPTION OF THE DRAWINGS**

[017] The accompanying drawings, which are incorporated in and constitute a part of this disclosure, illustrate exemplary embodiments and, together with the description, serve to explain the disclosed principles.

[018] **Figure 1** illustrates a schematic view of a compartmentalized refrigerator having an air passage duct arrangement with a damper assembly in a bypass position, in accordance with an embodiment of the present disclosure; and

[019] **Figure 2** illustrates an schematic view of the air passage duct arrangement with the damper assembly in an open position of Figure 1, in accordance with an embodiment of the present disclosure.

DETAILED DESCRIPTION OF THE DRAWINGS

[020] Exemplary embodiments are described with reference to the accompanying drawings. Wherever convenient, the same reference numbers are used throughout the drawings to refer to the same or like parts. While examples and features of disclosed principles are described herein, modifications, adaptations, and other implementations are possible without departing from the scope of the disclosed embodiments. It is intended that the following detailed description be considered as exemplary only, with the true scope being indicated by the following claims. Additional illustrative embodiments are listed.

[021] Embodiments of the present disclosure disclose an air passage duct arrangement for a compartmentalized refrigerator. The air passage duct arrangement is efficient and can be easily operated, thereby preventing increased consumption of power source and continuous operation of a compressor. In an embodiment of the air passage duct arrangement includes a damper assembly to selectively restrict ingress of the hot air from a fridge compartment to a freezer compartment.

[022] The following paragraphs describe the present disclosure with reference to Figures.1 and 2. In the figures, the same element or elements which have similar functions are indicated by the same reference signs.

[023] Referring to **Figure 1** to **Figure 2** which are exemplary embodiments of the present disclosure illustrating an air passage duct arrangement (100) [also referred as “duct arrangement (100)”] for a compartmentalized refrigerator (200). As will be understood, the duct arrangement (100) may be configured for the compartmentalized refrigerator (200) comprising at least a freezer compartment (202) and a fridge compartment (204).

[024] As shown in Figure. 1 and Figure. 2, the compartmentalized refrigerator (200) includes at least one freezer compartment (202) and fridge compartment (204) each defining therein a hollow interior. Further, each of the freezer compartment (202) and fridge compartment (204) comprises a door (205) pivotable coupled to a body of the compartmentalized refrigerator (200) to access the hollow interior. In an embodiment, the freezer compartment (202) may be configured above the fridge compartment (204). However,

this configuration of the freezer compartment (202) and the fridge compartment (204) may not be considered as a limitation. The freezer compartment (202) is maintained at a temperature lower than the fridge compartment (204).

5 [025] The duct arrangement (100) comprises a supply duct (10) fluidly connecting the freezer compartment (202) and the fridge compartment (204). The supply duct (10) is configured to direct cold air from the freezer compartment (202) to the fridge compartment (204). The supply duct (10) facilitates maintaining a pre-set temperature within the fridge compartment (204) by direction cold air from the freezer compartment (202) as the temperature within the freezer compartment (202) is substantially lower than the fridge compartment (204).
10 Further, a return duct (20) fluidly connects the freezer compartment (202) and the fridge compartment (204). The return duct (20) is being configured to direct a hot air from the fridge compartment (204) to the freezer compartment (202). This configuration of the supply duct (10) and the return duct (20) aids in circulation of the air within the each of the fridge and freezer compartments (204, 202), thereby maintaining pre-set temperature. The supply duct (10) and return duct (20) may be defined as an elongated hollow structure such that one end of each of the supply duct (10) and return duct (20) is fluidly connected to the freezer compartment (202) and other end is fluidly connected to the fridge compartment (204). Also, the duct arrangement (100) comprises a bypass duct (30) interconnecting the supply duct (10) and the return duct (20). In an embodiment, the bypass duct (30) interconnects an intermediate portion
20 of the supply duct (10) and return duct (20) as seen in Figure 1 and 2. The bypass duct (30) is fluidly connected to the supply and the return duct (10, 20) to circulate air flow only within at least one of the fridge compartment (204) and the freezer compartment (202).

[026] The air passage duct arrangement (100) comprises a damper assembly (40), configured in the supply duct (10), the return duct (20) and the bypass duct (30). The damper
25 assembly (40) is configured to be operated between a bypass position and an open position based on a condition of a door (205) of the fridge compartment (204). The damper assembly (40) includes a plurality of dampers comprising a first damper (12) configured in the supply duct (10), a second damper (22) is configured in the return duct (20), and a third damper (32) is configured in the bypass duct (30). The first damper (12), second damper (22) and third
30 damper (32) may be configured to have louver structure movably arranged within the supply duct (10), the return duct (20) and the bypass duct (30). In an embodiment, the first damper (12), second damper (22) and third damper (32) are pivotably disposed within the supply duct (10), the return duct (20) and the bypass duct (30). Further, each damper of the plurality of dampers is interconnected by a linkage mechanism (50). More particularly, the first damper

(12) is pivotably connected to second damper (22), and the second damper (22) is pivotably connected to the third damper (32) as seen in Figure 1. In an embodiment, the linkage mechanism (50) is coupled with the door (205) of the fridge compartment (204) and being configured to operate the plurality of dampers between the bypass position and the open position based on operation of the door (205) of the fridge compartment (204) between an open condition and a closed condition. More specifically, the third damper (32) is connected to the door (205) of the fridge compartment (204). The door (205) of the fridge compartment (204) is configured to be in the open condition and in the closed condition, such that in the open condition the door (205) pivotably moves about the body of the compartmentalized refrigerator (200) to access the hollow interior. In one of the operating conditions, in the open condition of the door (205), an ingress of air flows into the fridge compartment (204), increasing a pressure and temperature within the fridge compartment (204), thereby allowing the hot air to circulate within the fridge compartment (204) to the freezer compartment (202). Further, in the bypass position of the plurality of dampers i.e., the first damper (12), second damper (22) and third damper (32) may allow air to flow within the supply, the return and the bypass duct (10, 20, 30), respectively. In the open position of the plurality of dampers i.e., the first damper (12), second damper (22) and third damper (32) may restrict air to flow within the supply, the return and the bypass duct (10, 20, 30), respectively. Therefore, the damper assembly (40) selectively restricts ingress of the hot air from the fridge compartment (204) to the freezer compartment (202). In another embodiment, the each of the plurality of dampers is connected to at least one actuator [not seen in figures]. Thus, at least one actuator is connected to each of the first damper (12), second damper (22) and third damper (32) to move between open position and the bypass position. Further, the at least one actuator is coupled to the door (205) of the fridge compartment (204) and being configured to operate the plurality of dampers between the bypass position and the open position based on operation of the door (205) of the fridge compartment (204) between the open condition and the closed condition. More particularly one end of the actuator may be connected to the door (205) and other end with the plurality of dampers. Additionally, each of the actuator of at least one of the first damper (12), second damper (22) and third damper (32) may be coupled with at least one actuator provided at the door (205) of the fridge compartment (204). In an embodiment, the actuator may be at least one of electrical, hydraulic, pneumatic actuator and the like to operatively move the plurality of dampers in the open position and the bypass position.

[027] The duct arrangement (100) comprises a controller [not shown in Figures]. The controller is connected to at least one actuator and a power source. The controller is

configured to trigger the actuator to operate the plurality of dampers between the bypass position and the open position based on operation of the door (205) of the fridge compartment (204) between the open condition and the closed condition. Furthermore, at least one sensor is provided to the door (205). The at least one sensor is communicatively coupled with the controller to detect at least one of the open condition and closed condition of the door (205). Based on a detected condition of the door (205), the sensor sends a signal to the controller and, later the controller gives a command to the at least one actuator to the operate the plurality of dampers between the bypass position and the open position.

[028] In an operative configuration, when the door (205) is in the open condition an ambient temperature air enters into the fridge compartment (204) thereby increasing pre-set temperature and pressure within the fridge compartment and generating hot air. Thus, in this condition the ingress hot air tends to flow from the fridge compartment (204) towards the freezer compartment (202), as the air flows from high temperature to lower temperature via at least one supply duct (20). Thus, during operative configuration, the damper assembly (40) is actuated by at least one actuator, causing the first damper (12) and the second damper (22) being configured to close the supply duct (10) and the return duct (20), and the third damper (32) is configured open the bypass duct (30), in the bypass position of the damper assembly (40), thereby restricting ingress of the hot air into the freezer compartment (202). Thus, once the door (205) is closed, the ingress hot air still floats and circulates within the fridge compartment (204), therefore in order to attain the pre- set temperature, the damper assembly (40) is operated such that the first damper (12) and the second damper (22) are configured to open the supply duct (10) and the return duct (20), and the third damper (32) is configured to open the bypass duct (30), in the open position of the damper assembly (40), to supply the cold air into fridge compartment (204) and direct the hot air into the freezer compartment (202) as shown in Figure 2. Further, the plurality of dampers may revert to bypass position after a time delay.

[029] The above subject matter discloses the air passage duct arrangement (100) which provides ease of selectively handling the ingress of hot air. Further, duct arrangement (100) an energy efficient solution and reduces additional load on the compressor to maintain pre-set temperatures within the freezer and fridge compartment (202, 204). The duct arrangement eliminates rapid and substantial increasing temperature of the freezer compartment (202). Additionally, this aids in controlling the damper assembly in open and bypass position based on the open and closed condition of the door (205) of the fridge

compartment (204). The duct arrangement (100) is economical to manufacture and maintain, as it requires minimal components to operate.

[030] It is intended that the disclosure and examples be considered as exemplary only, with a true scope of disclosed embodiments being indicated by the following claims.

WE CLAIM:

1. An air passage duct arrangement (100) for a compartmentalized refrigerator (200) comprising at least a freezer compartment (202) and a fridge compartment (204), the air passage duct arrangement (100) comprising:
 - a supply duct (10), fluidly connecting the freezer compartment (202) and the fridge compartment (204), the supply duct (10) being configured to direct cold air from the freezer compartment (202) to the fridge compartment (204);
 - a return duct (20), fluidly connecting the freezer compartment (202) and the fridge compartment (204), the return duct (20) being configured to direct a hot air from the fridge compartment (204) to the freezer compartment (202);
 - a bypass duct (30) interconnecting the supply duct (10) and the return duct (20);
 - a damper assembly (40), configured in the supply duct (10), the return duct (20) and the bypass duct (30), the damper assembly (40) being configured to be operated between a bypass position and an open position based on a condition of a door (205) of the fridge compartment (204), to selectively restrict ingress of the hot air from the fridge compartment (204) to the freezer compartment (202).
2. The air passage duct arrangement (100) as claimed in claim 1, wherein the damper assembly (40) includes a plurality of dampers comprising a first damper (12) configured in the supply duct (10), a second damper (22) configured in the return duct (20), and a third damper (32) configured in the bypass duct (30).
3. The air passage duct arrangement (100) as claimed in claim 2, wherein the first damper (12) and the second damper (22) are configured to close the supply duct (10) and the return duct (20), and the third damper (32) is configured open the bypass duct (30), in the bypass position of the damper assembly (40), when the door (205) is in an open condition to restrict ingress of the hot air into the freezer compartment (202).
4. The air passage duct arrangement (100) as claimed in claim 3, wherein the first damper (12) and the second damper (22) are configured to open the supply duct (10) and the return duct (20), and the third damper (32) is configured to open the bypass duct (30), in the open position of the damper assembly (40), when the door (205) is in a closed condition to supply the cold air into fridge compartment (204) and direct the hot air into the freezer compartment (202).

5. The air passage duct arrangement (100) as claimed in claim 2, wherein each damper of the plurality of dampers is interconnected by a linkage mechanism (50).
6. The air passage duct arrangement (100) as claimed in claim 5, wherein the linkage mechanism (50) is coupled with the door (205) of the fridge compartment (204) and being configured to operate the plurality of dampers between the bypass position and the open position based on operation of the door (205) of the fridge compartment (204) between open condition and closed condition.
7. The air passage duct arrangement (100) as claimed in claim 2, wherein each of the plurality of dampers is connected to at least one actuator.
8. The air passage duct arrangement (100) as claimed in claim 7, wherein the at least one actuator is coupled to the door (205) of the fridge compartment (204) and being configured to operate the plurality of dampers between the bypass position and an open position based on operation of the door (205) of the fridge compartment (204) between open condition and closed condition.
9. The air passage duct arrangement (100) as claimed in claim 7, comprises a controller connected to at least one actuator and a power source, wherein the controller is configured to trigger the actuator to operate the plurality of dampers between the bypass position and an open position based on operation of the door (205) of the fridge compartment (204) between open condition and closed condition.
10. The air passage duct arrangement (100) as claimed in claim 9, comprises at least one sensor provided to the door (205), wherein the at least one sensor is communicatively coupled to the controller to detect at least one of the open condition and closed condition of the door (205) and operate the plurality of dampers between the bypass position and the open position.
11. A compartmentalized refrigerator (200), comprising:
 - a refrigerator body defining an inner space opened or closed by refrigerator doors (205), the inner space defining at least:
 - a freezer compartment (202);
 - a fridge compartment (204), fluidly connected to the freezer compartment (202) by an air passage duct arrangement, the air passage duct arrangement comprising:

a supply duct (10), fluidly connecting the freezer compartment (202) and the fridge compartment (204), the supply duct (10) being configured to direct cold air from the freezer compartment (202) to the fridge compartment (204);

a return duct (20), fluidly connecting the freezer compartment (202) and the fridge compartment (204), the return duct (20) being configured to direct a hot air from the fridge compartment (204) to the freezer compartment (202);

a bypass duct (30) interconnecting the supply duct (10) and the return duct (20);

a damper assembly (40), configured in the supply duct (10), the return duct (20) and the bypass duct (30), the damper assembly (40) being configured to be operated between a bypass position and an open position based on a condition of a door (205) of the fridge compartment (204), to selectively restrict ingress of the hot air from the fridge compartment (204) to the freezer compartment (202).

Dated this 30th day of January 2024

--Digitally Signed--
Bhanu Prasad (INPA No: 3253)
Head, IPR Dept.,
L&T Technology Services Limited,
DLF 3rd Block, 2nd Floor,
Manapakkam, Chennai, TN, 600089.

ABSTRACT

AN AIR PASSAGE DUCT ARRANGEMENT FOR A COMPARTMENTALIZED REFRIGERATOR

An air passage duct arrangement for a compartmentalized refrigerator comprising a supply duct, fluidly connecting a freezer compartment and a fridge compartment and configured to direct cold air from the freezer compartment to the fridge compartment. A return duct is fluidly connected to the freezer compartment and the fridge compartment being configured to direct a hot air from the fridge compartment to the freezer compartment. Further, a bypass duct interconnects the supply duct and the return duct. The air passage duct arrangement also includes a damper assembly, configured in the supply duct, the return duct and the bypass duct. The damper assembly is configured to be operated between a bypass position and an open position based on a condition of a door of the fridge compartment, to selectively restrict ingress of the hot air from the fridge compartment to the freezer compartment.

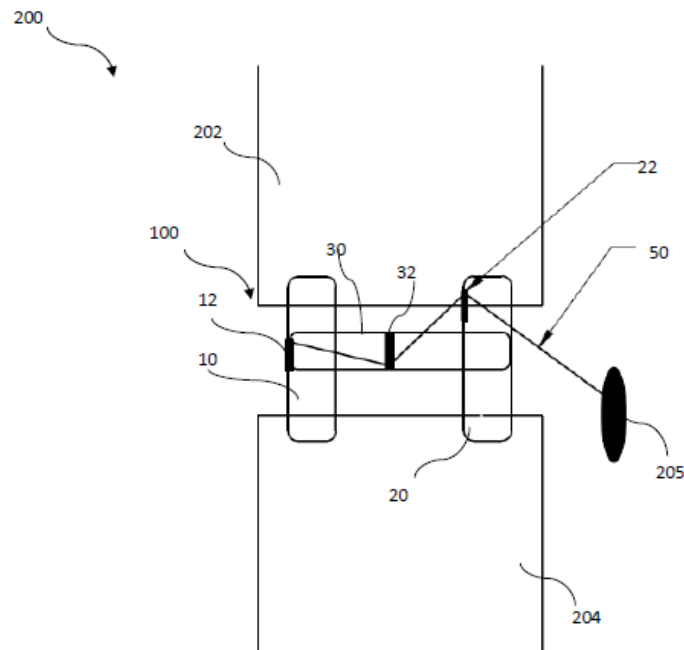

Fig.1

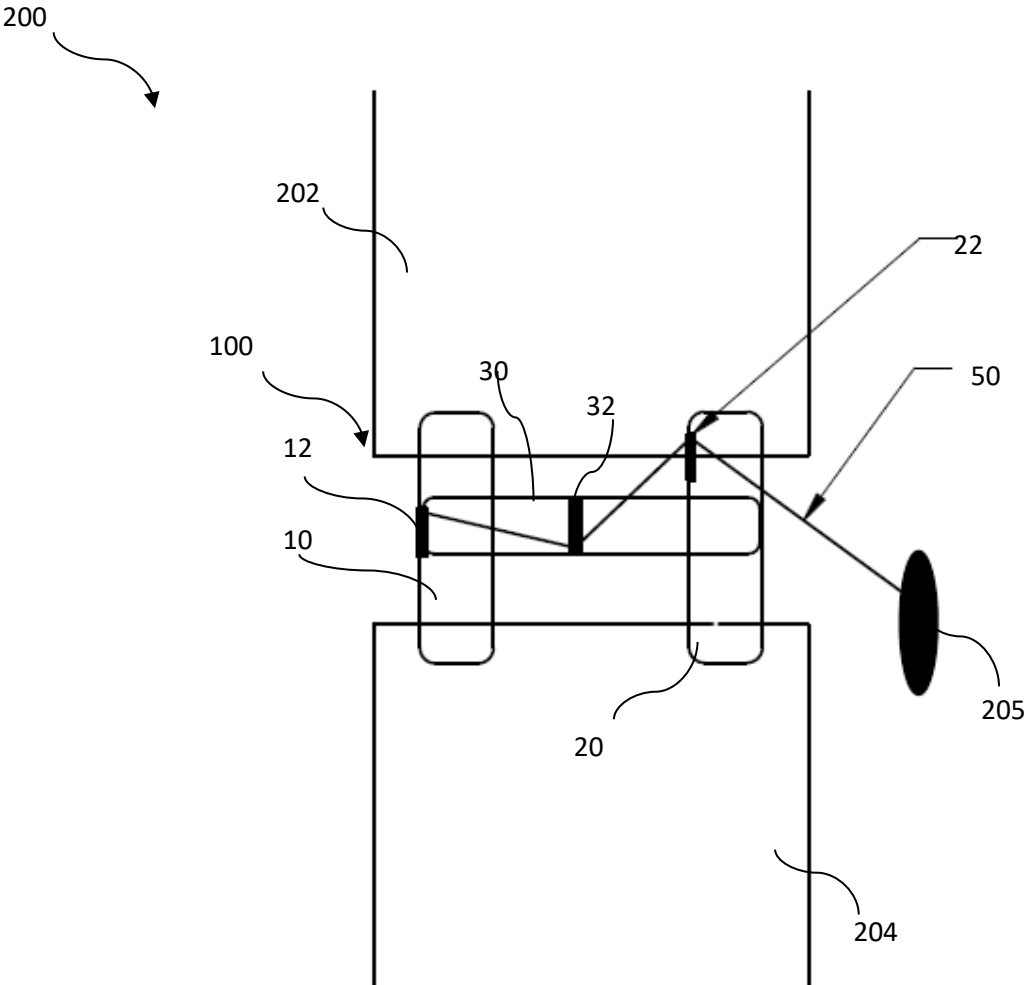

Fig.1

--Digitally Signed--
Bhanu Prasad (INPA No: 3253)
Head, IPR Dept.,
L&T Technology Services Limited,
DLF 3rd Block, 2nd Floor,
Manapakkam, TN, Chennai - 600089.

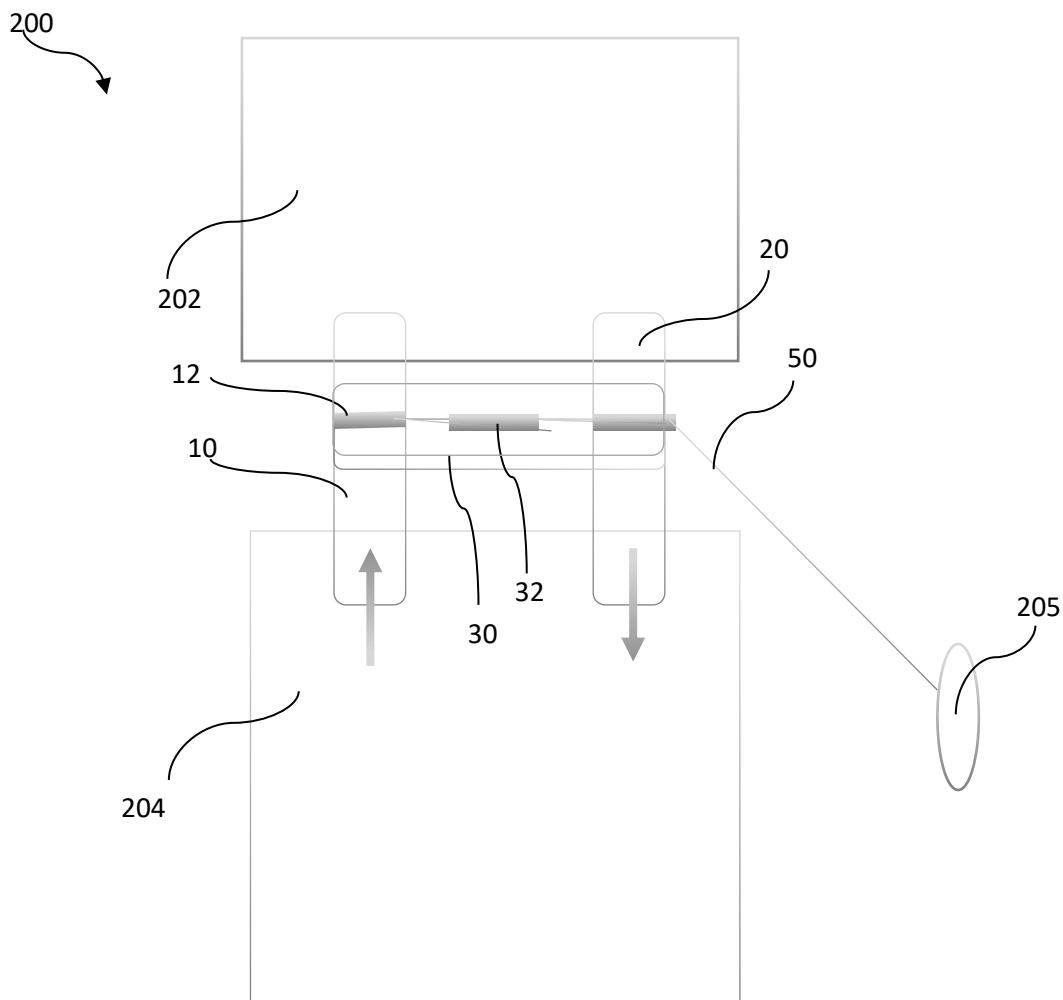

Fig 2

--Digitally Signed--
Bhanu Prasad (INPA No: 3253)
Head, IPR Dept.,
L&T Technology Services Limited,
DLF 3rd Block, 2nd Floor,
Manapakkam, TN, Chennai - 600089.