

# (12)Indian Patent Application

(21) Application Number: 202441020901

(22) Filing Date: 19/03/2024 (43) Publication Date: 26/09/2025

(71) Applicant(s): L&T TECHNOLOGY SERVICES LIMITED

(72) Inventor(s): Babu, Akshaya Poothanappilli

(51) International Classifications: G06T 5/10 G10L 25/30 G06T 5/00 G06N 3/04 G06N 3/08

(54) Title: METHOD AND SYSTEM OF CORRECTING GLARE IN REAL-TIME

(57) Abstract: A method (400) and system (100) of correcting glare in real-time is disclosed. A processor (104) receives a plurality of image frames by an imaging device (116). A grey-scale image frame of a corresponding image frame from the plurality of image frames is determined. The grey-scale image is converted to a frequency domain image frame. A peak frequency in the frequency domain image frame is determined. A filtered image is determined by attenuating the peak frequency in the frequency domain image frame. A filtered spatial domain image is determined from the filtered image frame. A corresponding ground truth image frame is determined based on the filtered spatial domain image. An unsupervised autoencoder neural network model is trained based on the ground truth image frame. A glare-corrected image frame corresponding to each of the plurality of image frames in real-time by the unsupervised autoencoder neural network model.

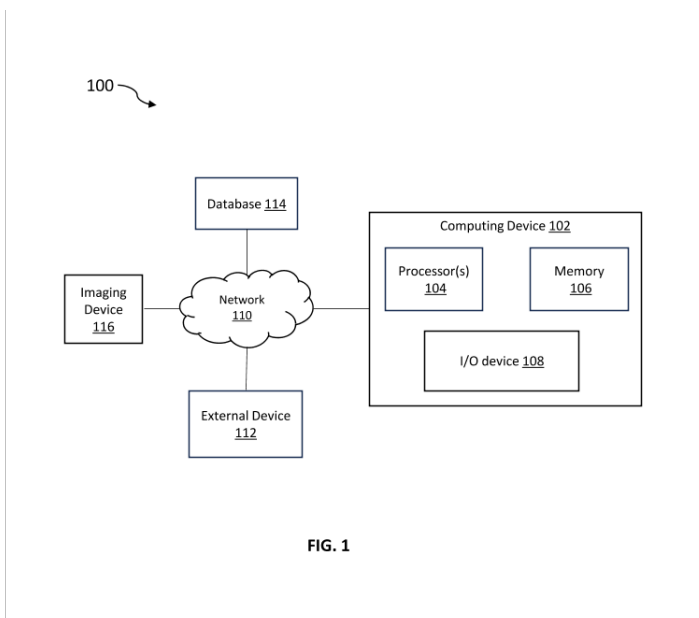

FIG. 1

# **FORM 2**

THE PATENTS ACT 1970  
(39 OF 1970)

&

The Patent Rules, 2003

## **Complete Specification**

(See Section 10 and Rule 13)

### **1. TITLE OF THE INVENTION**

**METHOD AND SYSTEM OF CORRECTING GLARE IN REAL-TIME**

### **2. APPLICANT(S)**

(a) NAME : **L&T TECHNOLOGY SERVICES LIMITED**

(b) NATIONALITY : **INDIAN**

(c) ADDRESS : **DLF IT SEZ Park, 2nd Floor – Block 3  
1/124, Mount Poonamallee Road,  
Ramapuram, Chennai – 600 089,  
INDIA.**

### **3. PREAMBLE TO THE DESCRIPTION**

#### **COMPLETE**

The following specification particularly describes the invention and the manner in which it is  
to be performed

## **DESCRIPTION**

### **Technical Field**

[001] This disclosure relates generally to image processing and more particularly to image processing using machine learning.

5

### **BACKGROUND**

[002] Driving systems are being constantly updated by adding improved features that enhance both driver comfort and safety. Such advanced features may be implemented using technologies such as autonomous and semi-autonomous driving systems, driving assistants, and advanced driver assistance systems (ADAS). In order to implement these features, various sensors such as imaging sensors may be utilized to provide real-time awareness of the surroundings, including details about parking spaces, obstacle positions, and road signs, etc.

10

[003] However, the imaging data captured by the imaging sensors may capture noise due to glare due to headlights of oncoming vehicles in opposite lane at night. Such glare in the images may obscure important information related to obstacles etc., making it difficult for the autonomous system to make accurate determination of the surroundings. Such situations could increase the risk of accidents. Further, glare correction may also be essential when real-time imaging is being performed in sunlight such as streaming live videos of an event.

15

[004] Traditional methodology of determining glare in an image involves using absolute luminance metering. These techniques mainly work by detecting and measuring the intensity of glare through the reflected light energy from an object. Further, the technique is dependent on various information regarding the size of the object reflecting the light, etc. which requires extra computational resources and are time consuming. Therefore, such techniques are not suitable for real-time image processing for correcting glare.

20

[005] Therefore, there is a requirement for an efficient glare correction system that demands fewer computational resources and can be implemented in real-time.

25

### **SUMMARY OF THE INVENTION**

[006] In an embodiment, a method for correcting glare is disclosed. The method may include receiving, by a processor, a plurality of image frames captured by an imaging device. The method may further include determining, by the processor, a glare-corrected image frame corresponding to each of the plurality of image frames in real-time by using an unsupervised autoencoder neural network model. In an embodiment, the unsupervised autoencoder neural

30

network model may be trained based on a ground truth image frame determined for each of the plurality of image frames. In an embodiment, the determination of ground truth images may include determining, by the processor, a grey-scale image frame of a corresponding image frame from the plurality of image frames. Further, the determination of ground truth images  
5 may include converting, by the processor, the grey-scale image frame to a frequency domain image frame by performing a Fourier transformation. The determination of ground truth images may further include determining, by the processor, a peak frequency in the frequency domain image frame and determining, by the processor, a filtered image frame by attenuating the peak frequency in the frequency domain image frame using a notch filter. Further, the determination  
10 of ground truth images may include determining, by the processor, a filtered spatial domain image from the filtered image frame by performing an inverse Fourier transformation. Further, the corresponding ground truth image frame may be determined based on the filtered spatial domain image and the corresponding image frame.

**[007]** In another embodiment, a system of correcting glare is disclosed. The system may  
15 include a processor and a memory communicably coupled to the processor, wherein the memory may store processor-executable instructions, which when executed by the processor may cause the processor to receive a plurality of image frames captured by an imaging device. The processor may further determine a glare-corrected image frame corresponding to each of the plurality of image frames in real-time by using an unsupervised autoencoder neural network  
20 model. In an embodiment, the unsupervised autoencoder neural network model may be trained based on a ground truth image frame determined for each of the plurality of image frames. In an embodiment, to determine the ground truth image frame for each of the plurality of image frames, the processor may be configured to determine a grey-scale image frame of a corresponding image frame from the plurality of image frames. The processor may further  
25 convert the grey-scale image frame to a frequency domain image frame by performing a Fourier transformation. The processor may further determine a peak frequency in the frequency domain image frame and determine a filtered image frame by attenuating the peak frequency in the frequency domain image frame using a notch filter. The processor may further determine a filtered spatial domain image from the filtered image frame by performing an inverse Fourier  
30 transformation. The processor may further determine the corresponding ground truth image frame based on the filtered spatial domain image and the corresponding image frame.

[008] Various objects, features, aspects, and advantages of the inventive subject matter will become more apparent from the following detailed description of preferred embodiments, along with the accompanying drawing figures in which like numerals represent like components.

5

### **BRIEF DESCRIPTION OF THE DRAWINGS**

[009] The accompanying drawings, which are incorporated in and constitute a part of this disclosure, illustrate exemplary embodiments and, together with the description, serve to explain the disclosed principles.

10

[010] FIG.1 illustrates a block diagram of an exemplary glare correction system for correcting glare in real-time, in accordance with an embodiment of the present disclosure.

[011] FIG.2 illustrates a functional block diagram of a computing device, in accordance with an embodiment of the present disclosure.

[012] FIG.3A illustrates an exemplary grey-scaled image frame, in accordance with an embodiment of the present disclosure.

15

[013] FIG.3B illustrates an exemplary frequency domain image frame, in accordance with an embodiment of the present disclosure.

[014] FIG.3C illustrates an exemplary peak frequency domain image frame, in accordance with an embodiment of the present disclosure.

20

[015] FIG.3D illustrates an exemplary filtered spatial domain image, in accordance with an embodiment of the present disclosure.

[016] FIG.3E illustrates an exemplary masked image frame, in accordance with an embodiment of the present disclosure.

[017] FIG.3F illustrates an exemplary glare-corrected ground truth image frame, in accordance with an embodiment of the present disclosure.

25

[018] FIG.4 illustrates a flowchart of a method of correcting glare in real-time, in accordance with an embodiment of the present disclosure.

### **DETAILED DESCRIPTION OF THE DRAWINGS**

[019] Exemplary embodiments are described with reference to the accompanying drawings. Wherever convenient, the same reference numbers are used throughout the drawings to refer

to the same or like parts. While examples and features of disclosed principles are described herein, modifications, adaptations, and other implementations are possible without departing from the scope of the disclosed embodiments. It is intended that the following detailed description be considered exemplary only, with the true scope being indicated by the following claims. Additional illustrative embodiments are listed.

[020] Further, the phrases “in some embodiments”, “in accordance with some embodiments”, “in the embodiments shown”, “in other embodiments”, and the like mean a particular feature, structure, or characteristic following the phrase is included in at least one embodiment of the present disclosure and may be included in more than one embodiment. In addition, such phrases do not necessarily refer to the same embodiments or different embodiments. It is intended that the following detailed description be considered exemplary only, with the true scope being indicated by the following claims.

[021] At night, the glare from the headlamps of cars in the opposite lane or the glare due to sun during the day hampers with the visibility of drivers and accounts for a lot of accidents. Further, in automatically driven cars such glare may be captured as noise in the imaging data captured by the imaging sensors. Accordingly, detection of obstacles and due to such glare related noise may become erroneous and may cause erroneous navigation of the vehicle leading to accidents.

[022] Accordingly, the present disclosure provides a method and system for correcting glare in real-time using machine learning.

[023] Referring now to **FIG. 1**, a block diagram of an exemplary glare correction system 100 for correcting glare in real-time is illustrated, in accordance with an embodiment of the present disclosure. The glare correction system 100 may include a computing device 102, an external device 112, a database 114, and an imaging device 116 communicably coupled to each other through a wired or wireless communication network 110. The computing device 102 may include a processor 104, a memory 106 and an I/O device 108.

[024] In an embodiment, examples of processor(s) 104 may include, but are not limited to, an Intel® Itanium® or Itanium 2 processor(s), or AMD® Opteron® or Athlon MP® processor(s), Motorola® lines of processors, Nvidia®, FortiSOC™ system on a chip processors or other future processors.

[025] In an embodiment the memory 106 may store instructions that, when executed by the processor 104 and cause the processor 104 to correct glare related noise in an image frame

captured in real-time, as discussed in more detail below. In an embodiment, the memory 106 may be a non-volatile memory or a volatile memory. Examples of non-volatile memory may include but are not limited to, a flash memory, a Read Only Memory (ROM), a Programmable ROM (PROM), Erasable PROM (EPROM), and Electrically EPROM (EEPROM) memory.

5 Further, examples of volatile memory may include but are not limited to, Dynamic Random Access Memory (DRAM), and Static Random-Access memory (SRAM).

**[026]** In an embodiment, the I/O device 108 may comprise of variety of interface(s), for example, interfaces for data input and output devices, and the like. The I/O device 108 may facilitate inputting of instructions by a user communicating with the computing device 102. In

10 an embodiment, the I/O device 108 may be wirelessly connected to the computing device 102 through wireless network interfaces such as Bluetooth®, infrared, or any other wireless radio communication known in the art. In an embodiment, the I/O device 108 may be connected to a communication pathway for one or more components of the computing device 102 to facilitate the transmission of inputted instructions and output results of data generated by  
15 various components such as, but not limited to, processor(s) 104.

**[027]** In an embodiment, the communication network 110 may be a wired or a wireless network or a combination thereof. The network 110 can be implemented as one of the different types of networks, such as but not limited to, ethernet IP network, intranet, local area network (LAN), wide area network (WAN), the internet, Wi-Fi, LTE network, CDMA network, 5G and the  
20 like. Further, network 110 can either be a dedicated network or a shared network. The shared network represents an association of the different types of networks that use a variety of protocols, for example, Hypertext Transfer Protocol (HTTP), Transmission Control Protocol/Internet Protocol (TCP/IP), Wireless Application Protocol (WAP), and the like, to communicate with one another. Further network 110 can include a variety of network devices,  
25 including routers, bridges, servers, computing devices, storage devices, and the like.

**[028]** In an embodiment, the imaging device 116 may include one or more sensors to capture a plurality of image frames. In an embodiment, the plurality of image frames may be transmitted to the computing device 102 via the network 110. In an embodiment example of the imaging device 116 may include but is not limited to, a digital camera, etc.

30 **[029]** In an embodiment, the database 114 may be enabled in a cloud or a physical database and may store a plurality of image frames as training data. In an embodiment, the database 114

may store data input by an external device 112 or output generated by the computing device 102.

5 **[030]** In an embodiment, the computing device 102 may receive a request for correcting glare in real-time from the external device 110. In an embodiment, the computing device 102 and the external device 110 may be a computing system, including but not limited to a laptop computer, a desktop computer, a workstation, a portable computer, a handheld, a scanner, or a mobile device. In an embodiment, the computing device 102 may be, but not limited to, in-built into the imaging device 116 or may be a standalone devices.

10 **[031]** In an embodiment, the computing device 102 may perform various processing for performing glare correction in real-time. By way of an example, the computing device 102 may receive a plurality of image frames captured by the imaging device 116. In an exemplary embodiment, the imaging device 116 may be provided in an autonomous vehicle to capture a front view of the vehicle in real-time, the imaging device 116 may capture a plurality of image frames that may include glare as noise due to the sun during the day or due to head lamps of  
15 vehicles travelling in the opposite lane.

**[032]** The computing device 102 may utilize an unsupervised autoencoder neural network model to determine a glare-corrected image frame corresponding to each of the plurality of image frames in real-time. In an embodiment, the unsupervised autoencoder may be a light weight deep learning model. Further, for initial few numbers of iterations, the unsupervised  
20 autoencoder neural network model may output the input image frames itself as it may be untrained. The unsupervised autoencoder neural network model may be trained based on determination of a ground truth image frame determined for each of the plurality of image frames.

25 **[033]** In order to determine a ground truth image for an image frame from the plurality of image frames, the computing device 102 may determine a grey-scale image frame of the corresponding image frame. Further, the computing device 102 may convert the grey-scale image frame to a frequency domain image frame by performing a Fourier transformation. Further, the computing device 102 may determine a peak frequency in the frequency domain image frame. Further, the computing device 102 may determine a filtered image frame by  
30 attenuating the peak frequency in the frequency domain image frame using a notch filter. Further, the computing device 102 may determine a filtered spatial domain image from the filtered image frame by performing an inverse Fourier transformation. Further, the computing

device 102 may determine a mask based on thresholding the filtered spatial domain image in order to determine pixels corresponding to the peak frequency in the corresponding image frame. In an embodiment, the thresholding of the filtered spatial domain image may be performed based on a predefined threshold level. Further, the computing device 102 may determine one or more masked pixels in the filtered spatial domain image using the mask.

[034] Further, the computing device 102 may determine a corresponding glare-corrected ground truth image frame based on the filtered spatial domain image and the corresponding image frame. In an embodiment, the determination of the glare-corrected ground truth image frame for each of the plurality of image frames may be based on determination of the corresponding glare-corrected ground truth image frame by replacing one or more pixels corresponding to the peak frequency in the corresponding image frame with the corresponding one or more masked pixels in the filtered spatial domain image. In an embodiment, the glare-corrected ground truth image frame for each of the plurality of image frame being captured in real-time may be determined as a backend process. As the unsupervised autoencoder neural network model is trained based on the glare-corrected ground truth image frames, the computing device 102 may start determining glare corrected image frames in real-time after an initial lag of a predefined time period. Accordingly, the accuracy of the unsupervised autoencoder neural network model may improve with time based on the training of the model based on the glare-corrected ground truth image frames determined by the computing device 102. In an embodiment, the unsupervised autoencoder neural network model may be trained based on previously determined grey scale corrected ground truth images for previously captured image frames.

[035] Further, the computing device 102 may train an unsupervised autoencoder neural network model in real time based on the glare-corrected ground truth image frame determined. In an embodiment, a training loss may be calculated between one or more features of the glare-corrected ground truth image and one or more features of the input image frames outputted by the unsupervised autoencoder. Further, the training loss may be backpropagated to the model to fine tune the unsupervised autoencoder. .

[036] Referring now to **FIG.2** a functional block diagram of computing device 102, in accordance with some embodiments of the present disclosure is illustrated. In an embodiment, the computing device 102 may include an image capturing module 202, a glare corrected image determination module 204. In an embodiment, the computing device 102 may receive a

plurality of input image frames captured by the image capturing module 204 via the imaging device 116. In an embodiment, the plurality of input image frames may include, but is not limited to real-time images that may include glare as noise. In an exemplary embodiment, the imaging device 116 may be provided in an autonomous vehicle to capture a front view of the vehicle in real-time. The imaging device 116 may capture a plurality of image frames that may include glare as noise due to the sun during the day or due to head lamps of vehicles travelling in the opposite lane at night.

[037] The glare corrected image determination module 204 may utilize an unsupervised autoencoder neural network model to determine glare corrected image frames for each of the plurality of image frames captured by the imaging capturing module 202. In an embodiment, the unsupervised autoencoder may be a light weight deep learning model.

[038] The glare corrected image determination module 204 may sub-include an autoencoder training module 206. The autoencoder training module 206 may train the unsupervised autoencoder neural network model based on a glare-corrected ground truth images determined for each of the plurality of image frames captured.

[039] Further in order to determine a ground truth image for an image frame from the plurality of image frames, the autoencoder training module 206 may sub-include a grey-scale image determination module 208, a frequency domain image determination module 210, a peak frequency determination module 212, a filtered image determination module 214, a filtered spatial domain image determination module 216, a mask determination module 218, a ground truth image determination module 220.

[040] In an embodiment, the grey-scale image determination module 208 may determine a grey-scale image frame of a corresponding input image frame from plurality of image frames. Referring now to **FIG. 3A**, an exemplary grey-scaled image frame 300A is illustrated, in accordance with an embodiment of the present disclosure. The grey-scale image frame 300A may be determined by transforming each pixel's colour information of the corresponding input image into a single intensity value. In accordance with the current embodiment, the corresponding input image may be an image with too much brightness or glare coming from the opposite side of the vehicle.

[041] Further the frequency domain image determination module 210 may convert the grey-scale image frame 300A into a frequency domain image frame by performing a Fourier transformation. In an embodiment, the frequency domain image frame may be determined

using a Fast Fourier Transformation (FFT) algorithm. Referring now to **FIG. 3B**, an exemplary frequency domain image frame 300B is illustrated, in accordance with an embodiment of the present disclosure. The frequency domain image frame 300B may be determined based on decomposition of the grey-scale image frame 300A into corresponding constituent frequencies in order to reveal the frequency content of the grey-scale image frame 300A.

[042] Further, the peak frequency determination module 212 may determine a peak frequency in the frequency domain image frame 300B. In an embodiment, the peak frequency in the peak frequency domain image frame may be determined by using a peak frequency detection algorithm. In order to determine the peak frequency, the frequency domain image frame 300B may be convolved using a kernel of size for example, but not limited to, 5x5. In an embodiment, the kernel value may be almost equal to the frequency of the glare which is required to be detected. The frequency domain image frame 300B may be convolved starting from a centre to across the x-axis and y-axis in positive and negative direction by the peak frequency determination module 212. During the convolution any region almost equivalent to the kernel value may be suppressed by masking it as that region may be considered corresponding to the peak frequency of glare. In an embodiment, the peak frequency determination algorithm determines a centre pixel value of the frequency domain image 300B as the peak frequency.

[043] Referring now to **FIG. 3C**, an exemplary peak frequency domain image frame 300C is illustrated, in accordance with an embodiment of the present disclosure. The peak frequency domain image frame 300C may include a spot 302 that may correspond to a peak frequency in the frequency domain image frame 300B.

[044] Accordingly, the filtered image determination module 214 may determine a filtered image frame by attenuating the peak frequency in the frequency domain image frame 300B using a notch filter. In accordance with the current embodiment, the notch filter may be a type of frequency domain filter that may be designed to remove specific frequencies or narrow bands of frequencies while leaving the rest of the spectrum unchanged.

[045] Further, the filtered spatial domain image determination module 216 may determine a filtered spatial domain image from the filtered image frame by performing an inverse Fourier transformation. In accordance with the current embodiment, the inverse Fourier transformation may be a process of converting a frequency domain representation back to the spatial domain. Referring now to **FIG. 3D**, an exemplary filtered spatial domain image 300D is illustrated, in accordance with an embodiment of the present disclosure.

[046] Further, the mask determination module 218 may determine a mask based on thresholding the filtered spatial domain image in order to determine pixels corresponding to the peak frequency in the corresponding image frame. In an embodiment, the thresholding of the filtered spatial domain image may be performed based on a predefined threshold level. In accordance with this embodiment, the predefined threshold level may be, but is not limited to 255. Referring now to **FIG. 3E**, an exemplary mask 300E is illustrated, in accordance with an embodiment of the present disclosure. The mask 300E may be determined based on masking the filtered spatial domain image 300D to filter out the glare area 304 and non-glare area 306 based on the peak frequency. In an embodiment, the glare area 304 may be an area corresponding to the peak frequency. In an embodiment, the mask 300E may have pixel value of 255 for the glare area 304 and , pixel value of 0 for the non-glare area 306.

[047] Further, the ground truth image determination module 220 may determine a corresponding glare-corrected ground truth image frame based on the filtered spatial domain image 300D and the corresponding image frame 300A. In an embodiment, the determination of the glare-corrected ground truth image frame for each of the plurality of image frames may be determined by determining one or more masked pixels in the filtered spatial domain image 300D using the mask 300E. Further, the corresponding ground truth image frame may be determined by replacing one or more pixels of the glare area 304 that may correspond to the peak frequency in the corresponding image frame with the corresponding one or more masked pixels in the filtered spatial domain image 300D. In an embodiment, the glare-corrected ground truth image frame for each of the plurality of image frame may be determined in real-time. In an embodiment, the glare-corrected ground truth image frame may be further processed using histogram equalization.

[048] In an embodiment, the glare-corrected ground truth image frame for each of the plurality of image frame being captured in real-time may be determined as a backend process. As the unsupervised autoencoder neural network model is trained based on the glare-corrected ground truth image frames, the glare corrected image determination module 204 may start determining glare corrected image frames in real-time after an initial lag of a predefined time period. Accordingly, the accuracy of the unsupervised autoencoder neural network model may improve with time based on the training of the model based on the glare-corrected ground truth image frames determined by the ground truth image determination module 220. In an embodiment, the unsupervised autoencoder neural network model may be trained based on previously determined grey scare corrected ground truth images for previously captured image frames.

[049] Referring now to **FIG. 3F**, an exemplary glare-corrected ground truth image frame 300F is illustrated, in accordance with an embodiment of the present disclosure. The glare-corrected ground truth image frame 300F may be determined by integrating the pixels of the glare area 304 from the filtered spatial domain image 300D and the pixels of the non-glare area 306 from the corresponding input image frame. Accordingly, the pixels corresponding to the glare area 304 may be used from the filtered spatial domain image 300D based on the mask 300E and the pixels of the input grey scale image frame 300A may be used for the non-glare area 306 to determine the glare-corrected ground truth image frame 300F.

[050] As will be appreciated by one skilled in the art, a variety of processes may be employed for correcting glare in real-time. For example, the exemplary system 100 and the associated computing device 102 may correct glare in real-time by the processes discussed herein. In particular, as will be appreciated by those of ordinary skill in the art, control logic and/or automated routines for performing the techniques and steps described herein may be implemented by the system 100 and the associated computing device 102 either by hardware, software, or combinations of hardware and software. For example, suitable code may be accessed and executed by the one or more processors on the system 100 to perform some or all of the techniques described herein. Similarly, application specific integrated circuits (ASICs) configured to perform some, or all of the processes described herein may be included in the one or more processors on the system 100.

[051] Referring now to **FIG. 4**, a flowchart of a method of correcting glare in real-time, in accordance with an embodiment of the present disclosure. In an embodiment, method 400 may include a plurality of steps that may be performed by the processor 104 to correct glare in real-time.

[052] **FIG. 4** is explained in conjunction with **FIGs. 1** and **2**. Each step of the method 400 may be executed by various modules of the computing device 102.

[053] At step 402, a plurality of image frames captured by the imaging device 116 may be received. In an embodiment, the plurality of input image frames may include, but is not limited to image frames that may include glare and are captured by the imaging device 116 in real-time.

[054] Further at step 404, a glare-corrected image frame may be determined corresponding to each of the plurality of image frames in real-time by using an unsupervised autoencoder neural network model. In an embodiment, the unsupervised autoencoder may be a light weight deep

learning model. Further at sub-step 406, the unsupervised autoencoder neural network model may be trained based on determination of a ground truth image frame determined for each of the plurality of image frames.

5 [055] Further the sub-step 406 may include the sub-steps 408-422. At sub-step 408, in order to determine a ground truth image for an image frame from the plurality of image frames, the computing device 102 may determine a grey-scale image frame 300A may be determined of a corresponding image frame from the plurality of image frames. In an embodiment, the grey-scale image frame 300A may be determined by transforming each pixel's colour information of the corresponding input image into a single intensity value.

10 [056] Further at sub-step 410, the grey-scaled image frame 300A may be converted into a frequency domain image frame 300B by performing a Fourier transformation. In an embodiment, the frequency domain image frame may be determined using a Fast Fourier Transformation (FFT) algorithm.

15 [057] Further at sub-step 412, a peak frequency 302 in the frequency domain image frame 300B may be determined using a peak frequency detection algorithm.

[058] Further at sub-step 414, a filtered image frame 300C is determined by attenuating the peak frequency 302 in the frequency domain image frame 300B using a notch filter.

[059] Further at sub-step 416, a filtered spatial domain image 300D may be determined from the filtered image frame 300C by performing an inverse Fourier transformation.

20 [060] Further at sub-step 418, a mask 300E may be determined based on thresholding the filtered spatial domain image 300D in order to determine pixels corresponding to the peak frequency in the corresponding image frame 300A. In an embodiment, the thresholding of the filtered spatial domain image 300D may be performed based on a predefined threshold level.

25 [061] Further at sub-step 420, one or more masked pixels may be determined in the filtered spatial domain image 300D using the mask 300E.

[062] Further at sub-step 422, a corresponding glare-corrected ground truth image frame 300F may be determined based on the filtered spatial domain image 300D and the corresponding input video frame 300A. Further the sub-step 422 may include a sub-step 424. At sub-step 424, the determination of the corresponding glare-corrected ground truth image frame 300F may be based on replacing one or more pixels corresponding to the peak frequency in the

30

corresponding image frames 300A with the corresponding one or more masked pixels in the filtered spatial domain image 300D. In an embodiment, the glare-corrected ground truth image frame for each of the plurality of image frame being captured in real-time may be determined as a backend process. As the unsupervised autoencoder neural network model is trained based on the glare-corrected ground truth image frames, the computing device 102 may start determining glare corrected image frames in real-time and may train the autoencoder neural network model based on the determined glare corrected image frames after an initial lag of a predefined time period. Accordingly, the accuracy of the unsupervised autoencoder neural network model may improve with time based on the training of the model based on the glare-corrected ground truth image frames determined by the computing device 102.

**[063]** In an embodiment, challenges for correcting glare in real time may include but are not limited to the requirement to run the algorithm quickly enough to correct glare in video frames as they are being streamed. Since conventional algorithms are extremely vast and are time consuming, they cannot be used in scenarios that require correction of glare in real-time. One such scenario includes determination of surroundings by autonomous vehicles using imaging sensors that may capture glare related noise due to high intensity lights from the headlights of the approaching vehicles. Accordingly, objects such as potholes and speed breakers may not be identified making the automatic navigation of the vehicle erroneous.

**[064]** Thus, the disclosed method and system overcomes the various technical problems related to glare-correction in real-time. The system provides a methodology of correcting glare in images being captured in real-time. The feedback loop in the training process allows for continuous learning and improvement of the auto encoder neural network model over time. The system's potential for broader applications in image processing and enhancement further demonstrates its effectiveness in addressing glare-correction in real-time video streaming.

**[065]** As will be appreciated by those skilled in the art, the techniques described in the various embodiments discussed above are not routine, or conventional, or well-understood in the art. The techniques discussed above provide for correcting glare in real-time.

**[066]** In light of the above-mentioned advantages and the technical advancements provided by the disclosed method and system, the claimed steps as discussed above are not routine, conventional, or well understood in the art, as the claimed steps enable the following solutions to the existing problems in conventional technologies. Further, the claimed steps bring an

improvement in the functioning of the device itself as the claimed steps provide a technical solution to a technical problem.

5 [067] The specification has described method and system for optimizing query input for generating codes using large language models. The illustrated steps are set out to explain the exemplary embodiments shown, and it should be anticipated that ongoing technological development will change the manner in which particular functions are performed. These examples are presented herein for purpose of illustration, and not limitation. Further, the boundaries of the functional building blocks have been arbitrarily defined herein for the convenience of the description. Alternative boundaries can be defined so long as the specified  
10 functions and relationships thereof are appropriately performed. Alternatives (including equivalents, extensions, variations, deviations, etc., of those described herein) will be apparent to persons skilled in the relevant art(s) based on the teachings contained herein. Such alternatives fall within the scope and spirit of the disclosed embodiments.

15 [068] It is intended that the disclosure and examples be considered as exemplary only, with a true scope of disclosed embodiments being indicated by the following claims.

**WE CLAIM:**

1. A method (400) of correcting glare, the method (400) comprising:

receiving (402), by a processor (104), a plurality of image frames captured by an imaging device; and

determining (404), by the processor (104), a glare-corrected image frame corresponding to each of the plurality of image frames in real-time by using an unsupervised autoencoder neural network model,

wherein the unsupervised autoencoder neural network model is trained based on a ground truth image frame determined for each of the plurality of image frames, and

wherein the ground truth image frame for an image frame of the plurality of image frames is determined by:

determining (408), by the processor (104), a grey-scale image frame of a corresponding image frame from the plurality of image frames;

converting (410), by the processor (104), the grey-scale image frame to a frequency domain image frame by performing a Fourier transformation;

determining (412), by the processor (104), a peak frequency in the frequency domain image frame;

determining (414), by the processor (104), a filtered image frame by attenuating the peak frequency in the frequency domain image frame using a notch filter;

determining (416), by the processor (104), a filtered spatial domain image from the filtered image frame by performing an inverse Fourier transformation; and

determining (422), by the processor (104), the corresponding ground truth image frame based on the filtered spatial domain image and the corresponding image frame.

2. The method (400) as claimed in claim 1, wherein the determination of the ground truth image frame for each of the plurality of image frames comprises:

determining (418), by the processor (104), a mask based on thresholding the filtered spatial domain image in order to determine pixels corresponding to the peak frequency in the corresponding image frame;

determining (420), by the processor (104), one or more masked pixels in the filtered spatial domain image using the mask; and

determining (424), by the processor (104), the corresponding ground truth image frame by replacing one or more pixels corresponding to the peak frequency in the corresponding

image frame with the corresponding one or more masked pixels in the filtered spatial domain image.

3. The method (400) as claimed in claim 1, wherein the thresholding of the filtered spatial domain image is performed based on a predefined threshold level.

4. The method (400) as claimed in claim 1, wherein the ground truth image frame for each of the plurality of image frames is determined in real-time.

5. The method (400) as claimed in claim 4, wherein the unsupervised autoencoder neural network model is trained in real-time based on the ground truth image frame determined for each of the plurality of image frames.

6. A system (100) for correcting glare in real-time, comprising:

a processor (104); and

a memory (106) communicably coupled to the processor (104), wherein the memory (106) stores processor-executable instructions, which, on execution, cause the processor (104) to:

receive a plurality of image frames captured by an imaging device and;

determine a glare-corrected image frame corresponding to each of the plurality of image frames in real-time by using an unsupervised autoencoder neural network model,

wherein the unsupervised autoencoder neural network model is trained based on a ground truth image frame determined for each of the plurality of image frames, and

wherein to determine the ground truth image frame for each of the plurality of image frames, the processor (104) is configurable to:

determine a grey-scale image frame of a corresponding image frame from the plurality of image frames;

convert the grey-scale image frame to a frequency domain image frame by performing a Fourier transformation;

determine a peak frequency in the frequency domain image frame;

determine a filtered image frame by attenuating the peak frequency in the frequency domain image frame using a notch filter;

determine a filtered spatial domain image from the filtered image frame by performing an inverse Fourier transformation; and

determine the corresponding ground truth image frame based on the filtered spatial domain image and the corresponding image frame.

7. The system (100) as claimed in claim 6, wherein to determine the ground truth image frame for each of the plurality of image frames, the processor (104) is configurable to:

determine a mask based on thresholding the filtered spatial domain image in order to determine pixels corresponding to the peak frequency in the corresponding image frame;

determine one or more masked pixels in the filtered spatial domain image using the mask; and

determine the corresponding ground truth image frame by replacing one or more pixels corresponding to the peak frequency in the corresponding image frame with the corresponding one or more masked pixels in the filtered spatial domain image.

8. The system (100) as claimed in claim 6, wherein the thresholding of the filtered spatial domain image is performed based on a predefined threshold level.

9. The system (100) as claimed in claim 6, wherein the ground truth image frame for each of the plurality of image frames is determined in real-time.

10. The system (100) as claimed in claim 9, wherein the unsupervised autoencoder neural network model is trained in real-time based on the ground truth image frame determined for each of the plurality of image frames.

Dated this 19<sup>th</sup> day of March 2024

***--Digitally Signed--***  
Bhanu Prasad (INPA No: 3253)  
Head, IPR Dept.,  
L&T Technology Services Limited,  
DLF 3rd Block, 2nd Floor,  
Manapakkam, Chennai, TN, 600089.

## ABSTRACT

### **METHOD AND SYSTEM OF CORRECTING GLARE IN REAL-TIME**

A method (400) and system (100) of correcting glare in real-time is disclosed. A processor (104) receives a plurality of image frames by an imaging device (116). A grey-scale image frame of a corresponding image frame from the plurality of image frames is determined. The grey-scale image is converted to a frequency domain image frame. A peak frequency in the frequency domain image frame is determined. A filtered image is determined by attenuating the peak frequency in the frequency domain image frame. A filtered spatial domain image is determined from the filtered image frame. A corresponding ground truth image frame is determined based on the filtered spatial domain image. An unsupervised autoencoder neural network model is trained based on the ground truth image frame. A glare-corrected image frame corresponding to each of the plurality of image frames in real-time by the unsupervised autoencoder neural network model.

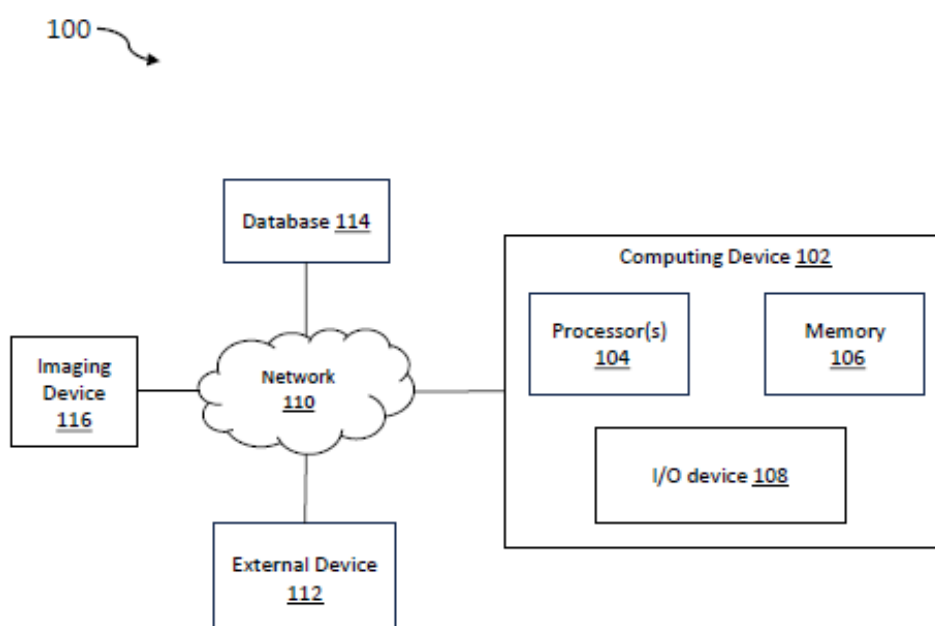

**FIG. 1**

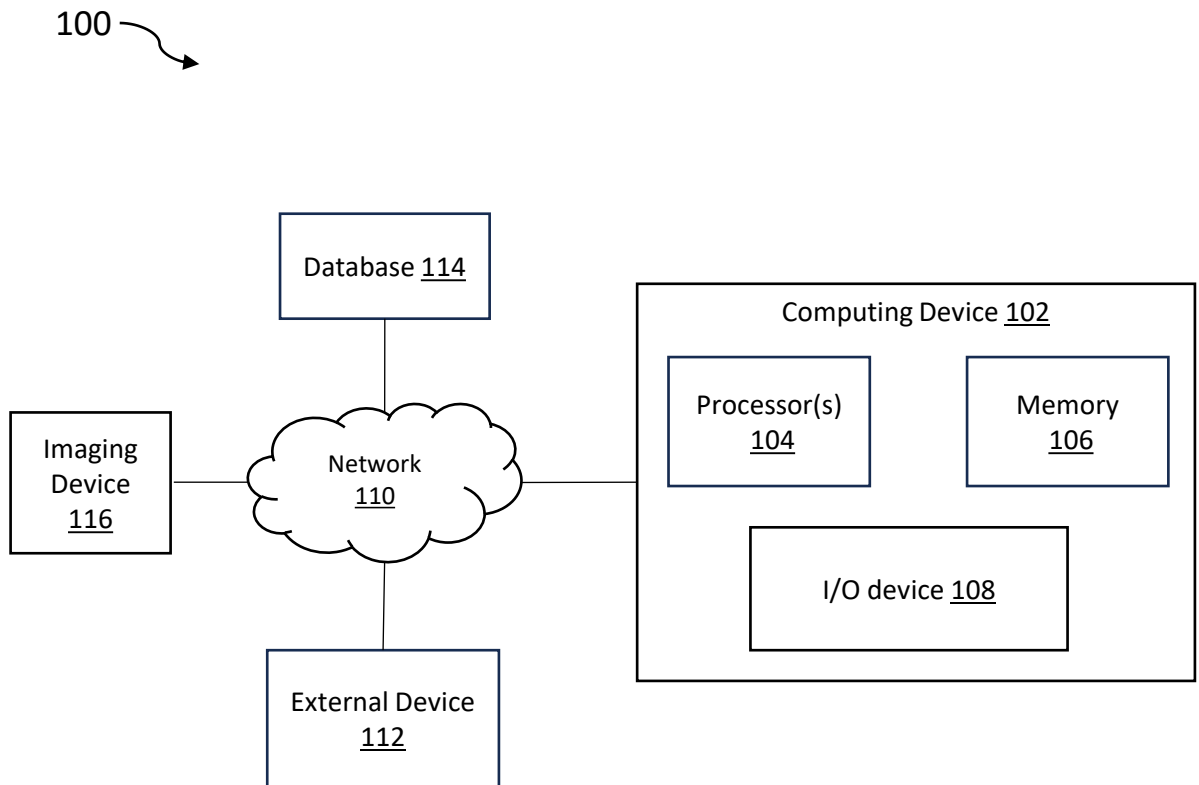

**FIG. 1**

200 →

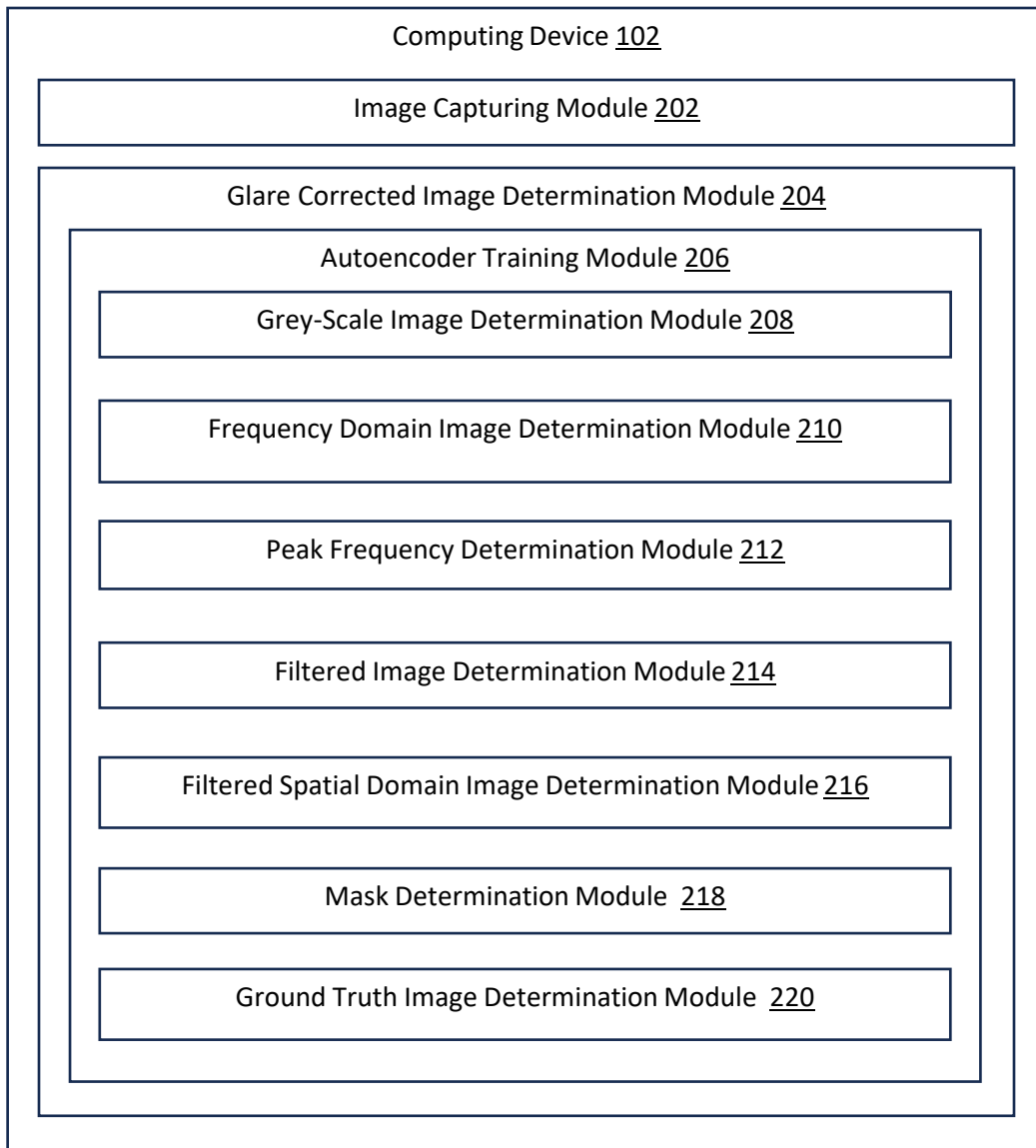

FIG. 2

300A



FIG. 3A

300B

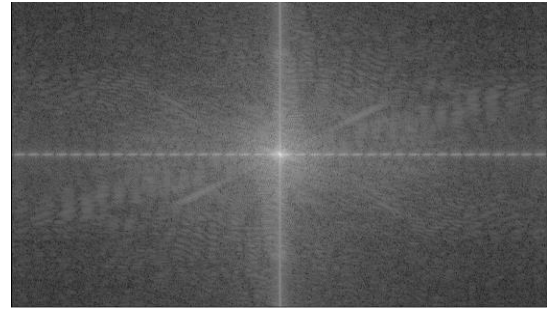

FIG. 3B

300C

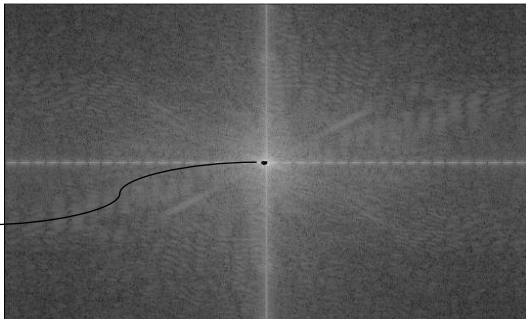

FIG. 3C

300D



FIG. 3D

300E



FIG. 3E

300F

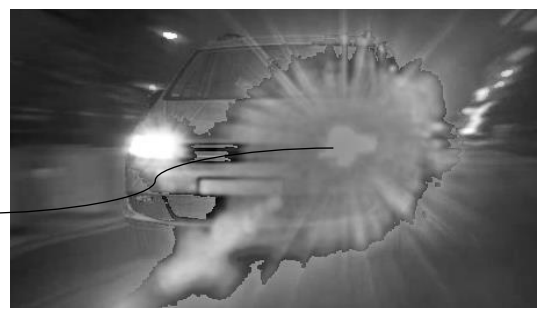

FIG. 3F

400

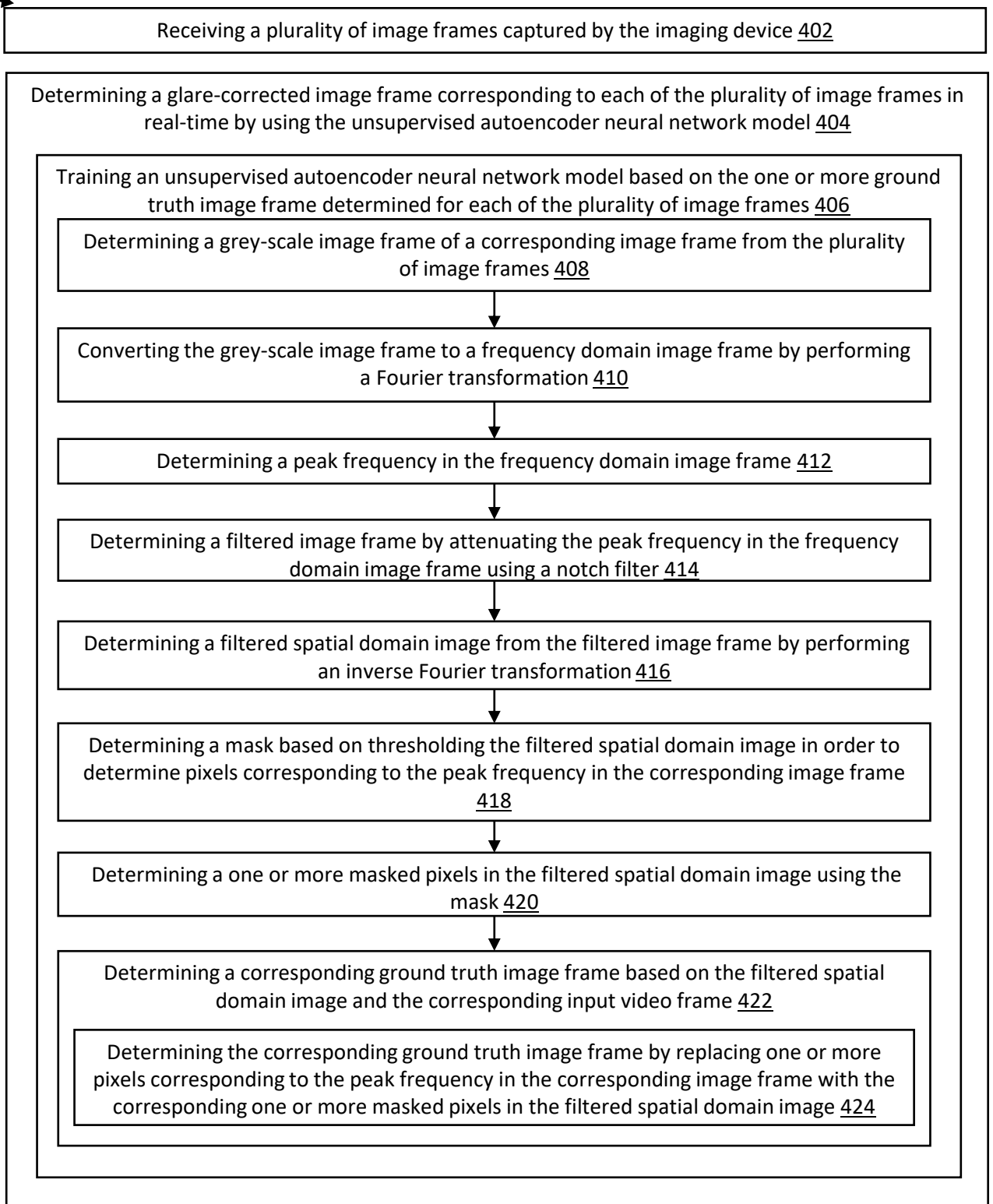

FIG. 4